

DRAFT PRELIMINARY ENGINEERING REPORT

Florida Department of Transportation

District One

Burnt Store Road PD&E Study

Limits of Project: From Van Buren Parkway to Charlotte County Line

Lee County, Florida

Financial Management Number: 436928-1-22-01

ETDM Number: 14380

Date: January 2025

The environmental review, consultation, and other actions required by applicable federal environmental laws for this project are being, or have been, carried out by the Florida Department of Transportation (FDOT) pursuant to 23 U.S.C. § 327 and a Memorandum of Understanding dated May 26, 2022 and executed by the Federal Highway Administration and FDOT.

\_\_\_\_\_  
Authorized Signature

Aniruddha Gotmare, PE

\_\_\_\_\_  
Print/Type Name

President, Scalar Consulting Group Inc.

\_\_\_\_\_  
Title

\_\_\_\_\_  
Address

\_\_\_\_\_  
Address

\_\_\_\_\_  
Seal

# PROFESSIONAL ENGINEER CERTIFICATION

## DRAFT PRELIMINARY ENGINEERING REPORT

**Project:** Burnt Store Road PD&E Study

**ETDM Number:** 14380

**Financial Project ID:** 436928-1-22-01

**Federal Aid Project Number:** D120 022 B

This preliminary engineering report contains engineering information that fulfills the purpose and need for the Burnt Store Road Project Development & Environment Study from Van Buren Parkway to Charlotte County Line in Lee County, Florida. I acknowledge that the procedures and references used to develop the results contained in this report are standard to the professional practice of transportation engineering as applied through professional judgment and experience.

I hereby certify that I am a registered professional engineer in the State of Florida practicing with Scalar Consulting Group Inc., and that I have prepared or approved the evaluation, findings, opinions, conclusions or technical advice for this project.

This item has been digitally signed and sealed by Aniruddha Gotmare, PE on the date adjacent to the seal.

Printed copies of this document are not considered signed and sealed and the signature must be verified on any electronic copies.

## TABLE OF CONTENTS

<b>1.0</b>	<b>PROJECT SUMMARY</b> .....	<b>1</b>
1.1	Project Description .....	1
1.2	Purpose and Need.....	2
1.3	Commitments .....	4
1.4	Alternatives Analysis Summary .....	5
1.5	Description of Preferred Alternative.....	6
1.6	List of Technical Documents.....	9
<b>2.0</b>	<b>EXISTING CONDITIONS</b> .....	<b>10</b>
2.1	Roadway Typical Section .....	10
2.2	Roadway Right-of-Way.....	11
2.3	Roadway Classification and Context Classification .....	11
2.4	Adjacent Land Use .....	11
2.5	Horizontal and Vertical Alignments.....	12
2.6	Pedestrian and Bicycle Facilities .....	12
2.7	Transit Facilities.....	12
2.8	Pavement Condition .....	12
2.9	Signalized Intersections.....	14
2.10	Railroad Crossings .....	14
2.11	Traffic Volumes and Operational Conditions .....	14
2.11.1	Intersection Layout and Traffic Control .....	14
2.11.2	Existing (2021) Traffic Volumes .....	14
2.11.3	Existing (2021) Traffic Operational Analysis .....	14
2.11.4	Crash Data and Safety Analysis .....	16
2.12	Access Management.....	19
2.13	Drainage.....	19

2.13.1	Drainage Basins.....	20
2.13.2	Existing Cross Drains.....	20
2.13.3	Floodplains/Floodways.....	21
2.13.4	Regional Hydrological Restoration Goals.....	21
2.14	Soils and Geotechnical Data .....	24
2.15	Structures .....	25
2.16	Navigable Waterways.....	28
2.17	Utilities.....	28
2.18	Lighting.....	28
2.19	Signage .....	29
2.20	Existing Environmental Features .....	30
2.21	Aesthetic Features.....	30
<b>3.0</b>	<b>PROJECT DESIGN CONTROLS AND CRITERIA.....</b>	<b>31</b>
3.1	Roadway Context Classification .....	31
3.2	Design Control and Criteria .....	31
<b>4.0</b>	<b>ALTERNATIVES ANALYSIS.....</b>	<b>33</b>
4.1	Previous Planning Studies.....	33
4.2	Future Traffic Conditions .....	33
4.3	No-Build Alternative.....	33
4.4	Transportation Systems Management and Operations .....	35
4.5	Alternative Corridors.....	36
4.6	Corridor Analysis .....	36
4.7	Build Alternative.....	36
4.8	Comparative Alternatives Evaluation.....	38
4.8.1	Roadway Alternatives Analysis Summary.....	38
4.8.2	Roadway Evaluation Matrix.....	43

4.8.3	Selection of the Roadway Preferred Alternative .....	43
4.8.4	Comparative Bridge Alternatives Evaluation .....	45
<b>5.0</b>	<b>PROJECT COORDINATION AND PUBLIC INVOLVEMENT .....</b>	<b>49</b>
5.1	Agency Coordination .....	49
5.2	Alternatives Public Meeting .....	50
5.3	Public Hearing .....	52
<b>6.0</b>	<b>DESIGN DETAILS OF THE PREFERRED ALTERNATIVE.....</b>	<b>53</b>
6.1	Typical Section .....	53
6.2	Design Variations and Design Exceptions .....	53
6.3	Intersection Layout and Access Management.....	54
6.3.1	Vincent Avenue Intersection Analysis .....	54
6.3.2	Continuous Green T Intersection Operation.....	56
6.4	Right-of-Way Needs and Relocations.....	56
6.5	Horizontal and Vertical Alignment.....	57
6.6	Bicycle and Pedestrian Accommodations.....	57
6.7	Future Traffic Conditions .....	59
6.7.1	Opening Year (2025) and Design Year (2045) Traffic Volumes .....	59
6.7.2	Opening Year (2025) and Design Year (2045) Traffic Operational Analysis .....	59
6.8	Preliminary Drainage Analysis.....	60
6.8.1	Hydraulics .....	60
6.8.2	Stormwater Management.....	61
6.9	Structural Analysis.....	63
6.10	Utility Impacts .....	64
6.11	Cost Estimates .....	65
6.12	Summary of Environmental Impacts.....	65
6.12.1	Farmlands .....	65

6.12.2	Historic Resources and Archaeological.....	65
6.12.3	Section 4(f).....	66
6.12.4	Natural Resources .....	68
6.12.5	Contamination.....	71
6.12.6	Air Quality .....	72
6.12.7	Highway Traffic Noise .....	72
6.12.8	Construction.....	72

**LIST OF TABLES**

Table 1-1:	Existing Traffic Conditions.....	3
Table 1-2:	Future Traffic Conditions.....	3
Table 1-3:	Evaluation Matrix .....	8
Table 1-4:	Technical Reports.....	9
Table 2-1:	Existing Horizontal Alignment .....	12
Table 2-2:	Existing (2021) Segment LOS Analysis.....	16
Table 2-3:	Burnt Store Road Link Service Volumes .....	16
Table 2-4:	Existing Drainage Basins .....	20
Table 2-5:	Existing Cross Drains.....	21
Table 2-6:	Existing Roadway Bridges .....	25
Table 2-7:	Existing Utility Owners .....	29
Table 3-1:	Roadway Design Criteria .....	32
Table 4-1:	Recommended Annual Growth Rates .....	33
Table 4-2:	No-Build Opening Year (2025) Segment LOS Analysis.....	34
Table 4-3:	No-Build Design Year (2045) Segment LOS Analysis .....	35
Table 4-4:	Build Opening Year (2025) Segment Analysis .....	37
Table 4-5:	Build Design Year (2045) Segment Analysis.....	37
Table 4-6:	Crash Modification Factors .....	38

Table 4-7: Evaluation Matrix .....	44
Table 5-1: Summary of Local Agency Meetings .....	49
Table 6-1: Proposed Horizontal Alignment.....	59
Table 6-2: Summary of Proposed Cross Drain Modifications .....	60
Table 6-3: Summary of Preferred Pond Sites.....	62
Table 6-4: Preferred Alternative Potential Utility Conflicts .....	64
Table 6-5: Project Cost Estimate .....	65
Table 6-6: Anticipated Wetland and Surface Water Impacts .....	69
Table 6-7: Summary of Federally Listed Species and Critical Habitat Effect Determinations .....	70
Table 6-8: Summary of State Listed Species Effect Determinations.....	71

## LIST OF FIGURES

Figure 1-1: Project Location Map .....	1
Figure 1-2: Preferred Alternative Typical Section .....	7
Figure 2-1: Photograph of Burnt Store Road facing north from south of NW 40 <sup>th</sup> Lane .....	10
Figure 2-2: Existing Typical Section .....	11
Figure 2-3: Existing Land Use Map .....	13
Figure 2-4: Existing (2021) Lane Configuration .....	15
Figure 2-5: Crash Summary by Year and Crash Severity.....	17
Figure 2-6: Burnt Store Road Crash Types (2015-2019).....	18
Figure 2-7: Burnt Store Road Crashes (2015-2019) by Road Surface Condition.....	18
Figure 2-8: Burnt Store Road Crashes (2015-2019) by Light Condition .....	19
Figure 2-9: FEMA Floodplain Map .....	22
Figure 2-10: Existing Bridge Typical Section (Bridge No. 120025) .....	26
Figure 2-11: Existing Bridge Typical Section (Bridge No. 124140) .....	27
Figure 2-12: Existing Bridge Typical Section (Bridge No. 120054) .....	28
Figure 4-1: Rural Typical Section Selected for Detailed Evaluation.....	40
Figure 4-2: Build Alternative 1 .....	42
Figure 4-3: Build Alternative 2.....	42
Figure 4-4: Bridge No. 120025 Option 1 Typical Section (four-lane configuration) .....	46
Figure 4-5: Bridge No. 120025 Option 1 Typical Section (six-lane configuration) .....	46
Figure 4-6: Bridge No. 120025 Option 2 Typical Section.....	47
Figure 4-7: Bridge No. 120054 Option 1 Typical Section.....	48
Figure 4-8: Bridge No. 120054 Option 2 Typical Section.....	48
Figure 6-1: Preferred Alternative Typical Section .....	53
Figure 6-2: Proposed Intersection Layout .....	58
Figure 6-3: Bridge No. 120025 Recommended Alternative (four-lane configuration).....	63



## **LIST OF APPENDICES**

APPENDIX A: Preferred Alternative Typical Section Package

APPENDIX B: Preferred Alternative Conceptual Plans

APPENDIX C: Long Range Estimate

APPENDIX D: Turning Movement Counts and Turning Movement Volumes

APPENDIX E: Lee County Access Management Resolution

APPENDIX F: Floodplain Update Memorandum

APPENDIX G: Intersection Control Evaluation Technical Memorandum

# 1.0 PROJECT SUMMARY

## 1.1 Project Description

The Florida Department of Transportation (FDOT), District One, is conducting a Project Development and Environment (PD&E) Study to evaluate the proposed widening of Burnt Store Road (CR 765) from Van Buren Parkway to the Charlotte County Line in Lee County. The study also extends a quarter mile north into Charlotte County to tie into the existing four-lane segment. The total project length is approximately 5.7 miles, and the project limits are shown in **Figure 1-1**. This project is within the City of Cape Coral and unincorporated Lee County.

**Figure 1-1: Project Location Map**

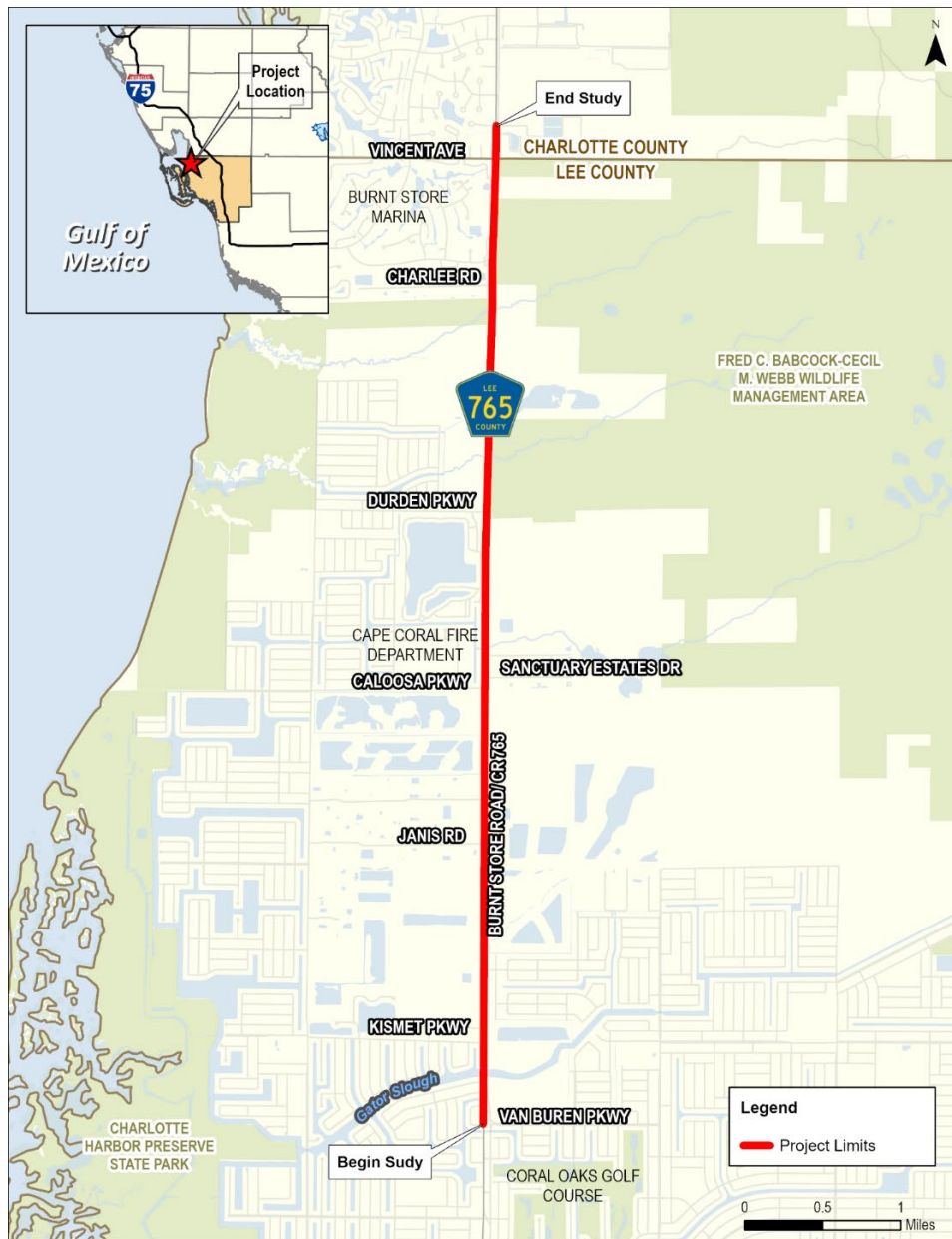

Within the majority of the project limits, Burnt Store Road is a two-lane, undivided facility with 12-foot travel lanes (one in each direction), with no paved shoulders and no pedestrian or bicycle facilities. An 8-foot unpaved shoulder is present in most locations. Posted speed limits are 50 and 55 miles per hour (MPH). There is one dual bridge crossing at Gator Slough Canal, of which the northbound bridge was recently constructed as part of the roadway widening project to the south. This waterway is not navigable. The Preferred Alternative has an urban typical section with curb and gutter and a closed roadway drainage system for the 4-lane construction. It provides future expandability to 6-lanes by allowing for widening to the median. The 200-foot typical section includes: two 11-foot travel lanes in each direction; a 40-foot median with eight-foot inside shoulders, four-foot paved; seven-foot buffered bicycle lanes; outside curb; and 10-foot shared use paths on each side of the roadway. The design and posted speeds are 50 MPH. The project does not cross any navigable waters.

The purpose of the PD&E Study is to evaluate and document the benefits, costs, and impacts of widening Burnt Store Road from the existing two-lane undivided roadway to four lanes. Similar to the roadway typical sections that exist north and south of this study segment, a goal was to develop a 4-lane typical section that would allow for future widening to 6-lanes by widening to the median. Also evaluated was the addition of paved shoulders/marked bicycle lanes, sidewalks, and/or shared-use paths. This study will aid Lee County, Lee Metropolitan Planning Organization (MPO), FDOT District One, and the FDOT Office of Environmental Management (OEM) in reaching a decision on the type, preliminary design, and location of the proposed improvements. This improvement is necessary to provide additional capacity to accommodate the future year travel demand generated by the projected population and employment growth in northwest Lee County and southwest Charlotte County. Burnt Store Road is a major north-south roadway that connects SR 78 (Pine Island Road) and US 41 and provides an important regional connection between coastal communities of Lee and Charlotte Counties. Burnt Store Road is an emergency evacuation route designated by the Florida Division of Emergency Management and Lee County.

The project was screened through Environmental Screening Tool (EST) as part of the Efficient Transportation Decision Making (ETDM) Programming Screen phase (ETDM #14380) and no major issues or disputes were noted by the Environmental Technical Advisory Team (ETAT). The Programming Screen Summary Report, prepared under separate cover, was published on September 4, 2020 and re-published on March 10, 2023 with the approved Class of Action (COA) of a Type 2 Categorical Exclusion (Type 2 CE). The study was conducted to meet the requirements of the National Environmental Policy Act (NEPA) and other related federal and state laws, rules, and regulations.

## **1.2 Purpose and Need**

The Purpose and Need statement was initially documented in the Programming Screen Summary Report: The purpose of this project is to address the deficient operational capacity of Burnt Store Road (CR 765) from Van Buren Parkway to north of the Charlotte County Line in order to accommodate future travel demand projected as a result of area-wide population and employment growth. Other goals of the project include enhancing system linkage/regional connectivity and improving safety conditions. The need for the project is based on the following criteria:

### **Capacity / Transportation Demand: Improve Operational Capacity**

Burnt Store Road serves as an important north-south corridor for commuters, in addition to freight traffic,

as it runs parallel and connects to regional transportation facilities (i.e., I-75, US 41, and SR 78) and provides access to several developments within Lee and Charlotte Counties. The existing 2021 Annual Average Daily Traffic (AADT) volumes within the project limits range from 9,800 to 14,000 vehicles per day (VPD). Based on the anticipated growth within the corridor, projected future 2045 traffic volumes range from 22,500 to 32,500 VPD under No-Build conditions (assuming no additional roadway capacity improvements beyond the existing two-lane roadway) and from 29,000 to 41,500 VPD under Build conditions (assuming widening of the corridor to four lanes and associated intersection and multi-modal improvements). By the 2045 design year, assuming no capacity improvements to the existing two-lane facility within the project limits, the corridor is expected to operate at Level of Service (LOS) F under No-Build conditions. A LOS F is a failing operating condition; a LOS D or better is an acceptable condition. As discussed in the PTAR, the LOS standard for Burnt Store Road is E and this is based on the 2022 Link Service Volumes on Arterials developed by Lee County, as referenced in the Public Facilities Level of Service and Concurrency Report, 2022 Inventory and Projections. These service volumes are based on the FDOT Level of Service tables. The existing and future traffic conditions for the Burnt Store Road project corridor are shown in **Table 1-1** and **Table 1-2**, respectively.

**Table 1-1: Existing (2021) Traffic Conditions**

Burnt Store Road Segment (Van Buren Parkway to Charlotte County Line)	2021 AADT Volume Range <sup>1</sup>	Daily Truck Percentage <sup>1</sup>	2021 LOS <sup>2</sup>
2 lanes undivided	9,800-14,000	11%	D or better

Notes/Sources:

- (1) AADT and daily truck traffic from the collected traffic counts
- (2) LOS measures for the study segments were developed using the Link Service Volumes on arterials developed by Lee County

**Table 1-2: Future (2045) Traffic Conditions**

Burnt Store Road Segment (Van Buren Parkway to Charlotte County Line)	2045 AADT Volume Range	2045 LOS
No Build: 2 lanes undivided	22,500-32,500	F
Build: 4 lanes divided	29,000-41,500	D or better

Notes/Sources:

- (1) 2045 AADT volumes were calculated using the linear growth rate
- (2) LOS measures for the study segments were developed using the Link Service Volumes on Arterials developed by Lee County

While the roadway currently operates above its designated LOS, conditions are anticipated to deteriorate if no improvements occur by 2045 as the roadway lacks the operational capacity to accommodate the projected travel demand. In turn, this will contribute to higher levels of congestion and delays. With the proposed four-lane widening of Burnt Store Road, the corridor is expected to continue to operate at acceptable LOS. The proposed improvement will also promote enhanced traffic flow, provide bicycle and pedestrian facilities and will help improve safety.

## **Area Wide Network / System Linkage: Improve Transportation Network Connectivity**

The project segment of Burnt Store Road is currently a two-lane facility, which connects to a four-lane rural typical section north of the Charlotte County Line. In addition, three segments south of the proposed project are being widened/have been widened from two lanes to four lanes. These include Pine Island Road (SR 78) to south of Tropicana Parkway, south of Tropicana Parkway to Diplomat Parkway, and Van Buren Parkway to Diplomat Parkway. The intent of this PD&E study is to enhance transportation network connectivity by addressing a traffic bottleneck and maintaining a critical link between residential and employment centers located both north in Charlotte County and south in Lee County.

## **Safety: Improve Emergency Evacuation and Response Times**

Serving as part of the emergency evacuation route network designated by the Florida Division of Emergency Management and Lee County, Burnt Store Road (CR 765) plays a critical role in facilitating traffic flow during emergency evacuation periods, as it runs parallel to both US 41 and I-75, which are designated north-south state evacuations routes in the western portions of both Lee and Charlotte Counties. Additionally, the Burnt Store Road (CR 765) corridor connects to Pine Island Road (SR 78), a designated east-west evacuation route. The existing roadway is prone to flooding, which impedes traffic. In addition, the western side of the project corridor is located in Lee County's Evacuation Zone "A", where many of the neighborhoods are within the 100-year floodplain; these areas are the most vulnerable as they will be the first to be impacted by a storm. The eastern side of the corridor is mostly in Evacuation Zone "C" with a small portion in Evacuation Zone "B."

The Florida Division of Emergency Management's Statewide Regional Evacuation Study Program for the Southwest Florida region has identified the project segment as critical and needing additional roadway capacity, due to extensive vehicle queues under various evacuation scenarios for different storm events. Delay caused by traffic congestion during evacuation events contributes to prolonged clearance times. Improving the operational capacity of the roadway, as well as bringing the roadway into compliance with current FDOT Manual of Uniform Minimum Standards for Design, Construction and Maintenance for Streets and Highways (commonly known as the Florida Greenbook) standards, will further enhance emergency evacuation efficiency leading to improved evacuation and emergency response times.

### **1.3 Commitments**

FDOT and Lee County are considering the following commitments:

- The most current version of the U.S. Fish and Wildlife Service (USFWS) Standard Protection Measures for the Eastern Indigo Snake will be implemented during construction.
- The most current version of the Florida Fish and Wildlife Conservation Commission (FWC) Standard Manatee Conditions for In-Water Work will be implemented during construction.
- If the listing status of the tricolored bat is elevated by the USFWS to Threatened or Endangered and the Preferred Alternative is located within the consultation area during the design and permitting phase of the proposed project, Lee County commits to re-initiating consultation with the USFWS to determine the appropriate survey methodology and to address USFWS regulations regarding the protection of the tricolored bat.

- Impacts to suitable foraging habitat for the wood stork will be mitigated through the purchase of credits from a USFWS-approved mitigation bank pursuant to Section 373.4137, F.S., or as otherwise agreed to by Lee County and the USFWS.
- The Protected Species Construction Conditions (NOAA Fisheries Southeast Regional Office) will be implemented to ensure that sea turtles and smalltooth sawfish will be adversely impacted by the project.
- Consultation with the NMFS for the smalltooth sawfish and Gulf sturgeon will be completed during the design phase of the project when the Gator Slough Canal bridge construction details are known.
- As per the Florida Bonneted Bat Consultation Key (2019), Best Management Practice (BMP) #1 is required for this project: If potential roost trees or structures need to be removed, check cavities for bats within 30 days prior to removal of trees, snags, or structures. When possible, remove structure outside of breeding season (e.g., January 1 – April 15). If evidence of use by any bat species is observed, discontinue removal efforts in that area and coordinate with the Service on how to proceed.
- As per the Florida Bonneted Bat Consultation Key (2019), BMP #4 is required for this project: For every 5 acres of impact, retain a minimum of 0.25 acre of native vegetation. If upland habitat is impacted, then upland habitat with native vegetation should be retained.
- As per the Florida Bonneted Bat Consultation Key (2019), BMP #7 is being considered for this project: Avoid or limit widespread application of insecticides (e.g., mosquito control, agricultural pest control) in areas where Florida bonneted bats are known or expected to forage or roost.
- As per the Florida Bonneted Bat Consultation Key (2019), BMP #10 is being considered for this project: Protect known Florida bonneted bat roost trees, snags or structures and trees or snags that have been historically used by Florida bonneted bats for roosting, even if not currently occupied, by retaining a 250 foot (76 m) disturbance buffer around the roost tree, snag, or structure to ensure that roost sites remain suitable for use in the future.
- As per the Florida Bonneted Bat Consultation Key (2019), BMP #11 is being considered for this project: Avoid and minimize the use of artificial lighting, retain natural light conditions, and install wildlife friendly lighting (i.e., downward facing and lowest lumens possible). Avoid permanent night-time lighting to the greatest extent practicable.
- As per the Florida Bonneted Bat Consultation Key (2019), BMP #12 is being considered for this project: Incorporate engineering designs that discourage bats from using buildings or structures. If Florida bonneted bats take residence within a structure, contact the Service and Florida Fish and Wildlife Conservation Commission prior to attempting removal or when conducting maintenance activities on the structure.

#### **1.4 Alternatives Analysis Summary**

Through early coordination with Lee County, it was discussed that for consistency with adjacent improved sections of Burnt Store Road, a roadway typical section that allows for expansion to a future six-lane facility was appropriate for the project corridor. The original roadway alternative consisted of a four-lane rural typical section expandable to a six-lane suburban typical section, with 11-foot travel lanes, a 52-foot median that would be reduced to 30-feet when ultimately widened to 6-lanes, ten-foot shoulders with seven-feet paved, and a 10-foot shared-use path on the west side and 12-foot shared use path on the east side. However, given drainage conditions in the project area, the need to raise the roadway elevation

by up to three feet, and the need to accommodate significant flows from east to west, these rural alternatives were determined, following detailed modeling, to require a minimum of 235 feet of ROW and up to 272 feet of ROW. Following coordination with Lee County, rural alternatives were discarded from further consideration given the ROW impacts.

Suburban and urban typical sections were then developed. The Suburban Option, requiring approximately 213 feet, included 11-foot travel lanes, a 30-foot median, seven-foot shoulders/bike lanes, a 10-foot shared-use path on one side and 12-foot shared use path on the other side of the road, and an open drainage system with comingling of water on each side. The 30-foot median would be reduced to 22-feet when ultimately widened to 6-lanes but this would require shifting of the lanes, reconstruction of the shoulders and the shared use paths. Urban Option 1, requiring approximately 220 feet of ROW, included 11-foot travel lanes, a 40-foot median that would be reduced to 22-feet when ultimately widened to 6-lanes, seven-foot shoulders/bike lanes with outside curb on both sides, a 10-foot shared-use path on both sides of the road, a closed roadway drainage system, and an open ditch on approximately two-thirds of the project limits to capture offsite flows and convey water to the west side. Urban Option 2, generally requiring 200-feet of ROW but requiring some minor ROW impacts, was similar to Urban Option 1 but eliminated the shoulders/bike lanes, included 12-foot shared use paths on both sides, and changed ditch slopes in an effort to fit within the existing ROW.

An optimized alignment was selected, meaning that widening was proposed on different sides of the roadway in different locations throughout the corridor to avoid sensitive resources and developed parcels. The suburban typical section option was discarded due to ROW impacts and Urban Option 2 was discarded since it lacked the shoulders and bike lanes and still required some ROW impacts. The Urban Option 1 alternative was ultimately named Build Alternative 1 and was carried forward for analysis.

Since reduction of ROW impacts was a prime focus, a third urban typical section alternative, Urban Option 3, was later developed that closely approximated Build Alternative 1 but included the design of a pipe instead of an open ditch to capture offsite flows. Horizontal alignments were similarly modeled, and the optimized alignment was found to be the only alternative analyzed that fits within the existing 200-feet of ROW, with the one exception of a utility property. However, like the other alternatives, utility parcel impacts were minimal. Urban Option 3 was renamed to Build Alternative 2 and was carried forward. Following detailed analysis, Build Alternatives 1 and 2 were presented to the public in the Alternatives Public Meeting.

## **1.5 Description of Preferred Alternative**

The Preferred Alternative, Build Alternative 2, meets the purpose and need for the project as it provides for improved operational capacity, transportation network connectivity, and emergency evacuation and response times. The Preferred Alternative has an urban typical section with curb and gutter and a closed roadway drainage system for the 4-lane construction. It provides future expandability to 6-lanes by allowing for widening to the median. The 200-foot typical section includes: two 11-foot travel lanes in each direction; a 40-foot median with eight-foot inside shoulders, four-foot paved; seven-foot buffered bicycle lanes; outside curb; and 10-foot shared use paths on each side of the roadway. The design and posted speeds are 50 miles per hour (MPH). **Figure 1-2** depicts the Preferred Alternative typical section.

Of the four alternatives initially considered, and the two alternatives that were more fully evaluated (Build Alternatives 1 and 2), this is the only alternative that generally eliminates ROW impacts for mainline widening (excluding stormwater management facilities), fitting within the existing 200-feet of ROW with the exception of a single parcel impact at the north project limit in Charlotte County. This is accomplished through the design of a pipe instead of an open ditch to capture offsite flows that are conveyed under the roadway. Stormwater runoff will be collected and conveyed to stormwater management facilities that will be constructed along the corridor. Impacts to floodplains will be mitigated with the construction of floodplain compensation sites. The approved typical section package and the concept plans for the Preferred Alternative are provided in **Appendix A** and **Appendix B**, respectively.

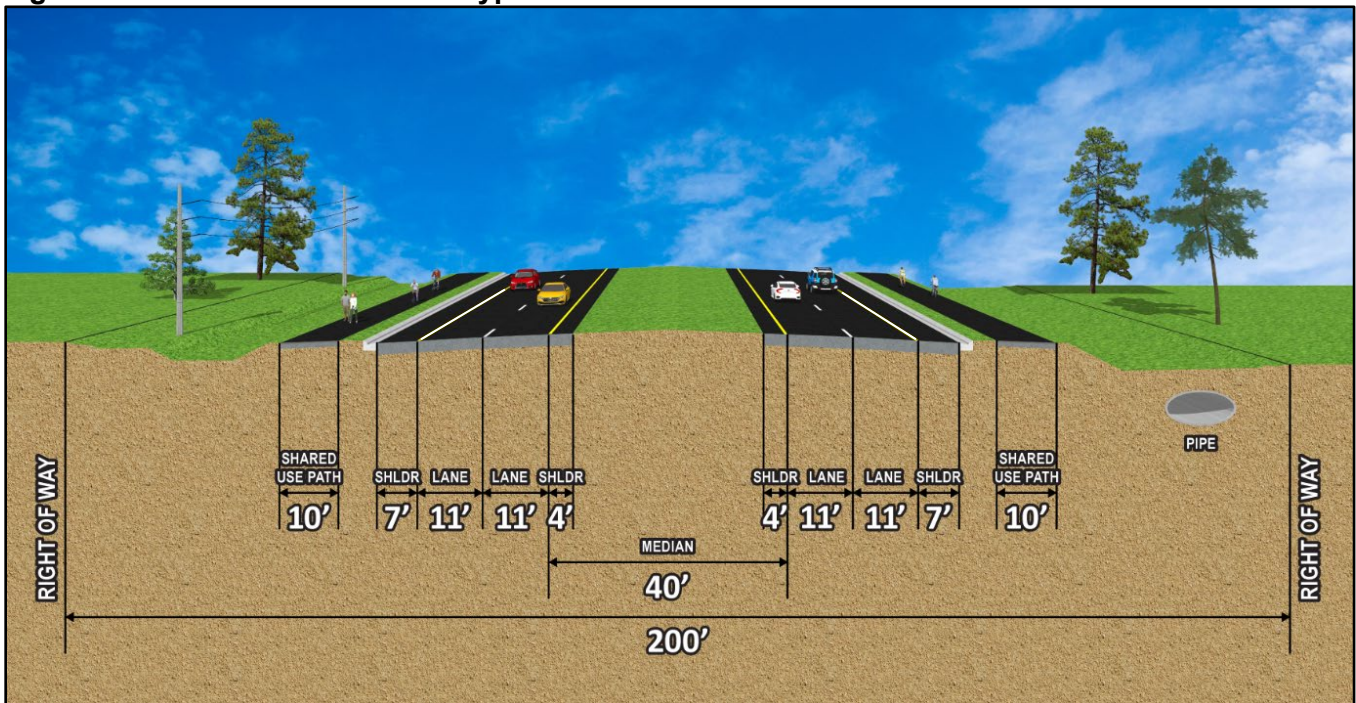

**Figure 1-2: Preferred Alternative Typical Section**



An evaluation matrix comparing the No-Build Alternative to the Preferred Alternative is shown in **Table 1-3**. The evaluation matrix includes environmental effects, residential and business relocations, ROW needs, and project costs including ROW acquisition, wetland mitigation, design, and construction engineering and inspection. Construction costs are based on December 2024 unit costs and were estimated using the FDOT Long Range Estimate (LRE) provided in **Appendix C**.



**Table 1-3: Evaluation Matrix**

Evaluation Factors	Preferred Alternative	No-Build Alternative
<b>Benefits</b>		
Reduced traffic congestion		
Bicycle accommodations		
Pedestrian accommodations		
Increased pedestrian/bicycle safety		
Enhanced safety for all users including hurricane evacuation		
<b>Right-of-Way Impacts</b>		
Right-of-way to be acquired for roadway (acres)	0.2	0
Right-of-way to be acquired for stormwater management (acres)	35.8	0
Number of business parcels impacted	0	0
Number of utility parcels impacted	1	0
Number of residential parcels impacted	0	0
Number of undeveloped parcels impacted	33	0
Number of business or residential relocations	0	0
<b>Environmental Effects</b>		
Number of archaeological/historic sites impacted	0 / 0	0 / 0
County conservation and recreation land impacts (parcels / acres)	0 / 0	0 / 0
State conservation and recreation land impacts (parcels / acres)	0 / 0	0 / 0
Wetlands and surface water impacts (acres)	33.5	0.0
Threatened and endangered species (potential)	Low	None
Number of noise sensitive sites impacted	5	0
Number of contamination sites with medium or high contamination risk	2 / 0	0 / 0
Farmland impacts (acres)	11.4	0.0
Floodplain impacts (acre-feet)	8.24-25.07*	0.0
<b>Estimated Project Costs (subject to change)</b>		
Final design	\$13,400,000	\$0
Right-of-way for roadway (to be purchased)	\$1,035,000	\$0
Right-of-way for stormwater management (to be purchased)	\$25,500,000	\$0
Wetland mitigation	\$2,525,000	\$0
State land mitigation (Acquisition Restoration Council process)	\$0	\$0
Roadway construction	\$133,995,000	\$0
Construction engineering and inspection	\$13,400,000	\$0
<b>Preliminary Estimate of Total Project Cost</b>	<b>\$189,855,000</b>	<b>\$0</b>

\* The higher limit is based on tidal still water elevations; final determination to be made during the design phase.

Note: cost estimates reflect December 2024 unit costs

## 1.6 List of Technical Documents

The technical reports prepared in support of this study and their respective completion dates are listed in Table 1-4.

**Table 1-4: Technical Reports**

<b>Document</b>	<b>Date</b>
<b>Public Involvement</b>	
Advance Notification Package	April 2020
Public Involvement Program	June 2020
Public Hearing Transcript	TBD
Comments and Coordination Report	TBD
<b>Engineering</b>	
Project Traffic Analysis Report	August 2022
Bridge Hydraulics Report	January 2023
Location Hydraulics Report	January 2023
Preliminary Roadway Soil Survey Report	August 2022
Pond Siting Report	January 2023
Preliminary Engineering Report	TBD
Utility Assessment Package	January 2023
<b>Environmental</b>	
Contamination Screening Evaluation Report	September 2022
Cultural Resource Assessment Survey	July 2022
Cultural Resource Assessment Survey Addendum	December 2022
ETDM Summary Report	April 2020
Farmlands Evaluation	January 2023
Natural Resources Evaluation	February 2023
Noise Study Report	December 2024
Section 4(f) No Use and Exceptions/Exemptions Forms	January 2023
Water Quality Impact Evaluation	August 2022
Type 2 Categorical Exclusion	TBD

## 2.0 EXISTING CONDITIONS

---

### 2.1 Roadway Typical Section

Within the majority of the project limits, Burnt Store Road is a two-lane, undivided facility with 12-foot travel lanes (one in each direction), with no paved shoulders and no pedestrian or bicycle facilities. An 8-foot unpaved shoulder is present in most locations. Posted speed limits are 50 and 55 MPH. Based on the 1976 as-built plans, the design speed is 65 MPH. Stormwater runoff is collected in roadside ditches and swales, and ultimately conveyed to Charlotte Harbor. There is one dual bridge crossing at Gator Slough Canal, of which the northbound bridge was recently constructed as part of the roadway widening project to the south. There are ten culvert crossings, which include a bridge culvert over Yucca Pens Creek. There are no signalized intersections along the corridor. Overhead and buried utilities are located primarily on the west side of the project. There are multiple county and state-owned conservation lands along both sides of the project limits. **Figure 2-1** provides a photograph of the existing roadway and **Figure 2-2** depicts the existing typical section for Burnt Store Road.

**Figure 2-1: Photograph of Burnt Store Road facing north from south of NW 40<sup>th</sup> Lane**



**Figure 2-2: Existing Typical Section**

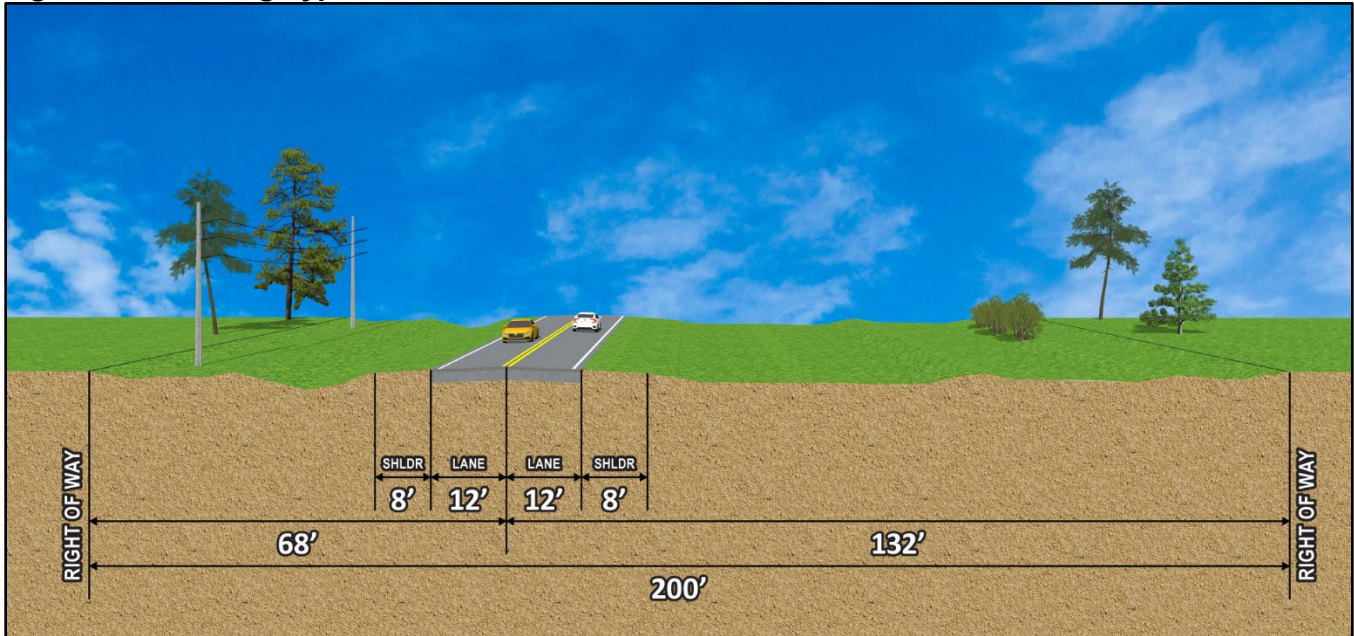

## 2.2 Roadway Right-of-Way

The existing right-of-way information was obtained from FDOT ROW maps when Burnt Store Road was originally constructed, Lee County as-built plans for small segments of the project area, Florida Department of Environmental Protection (FDEP) certified corner records, and property appraiser maps from Lee County. While generally the right-of-way along the corridor is 200-foot width within the project limits, this reduces to approximately 140-foot width north of the Lee County Line. South of the project limits, the ROW is 355 feet in width. Within the existing 200-foot ROW, the current Burnt Store Road horizontal alignment is shifted to the west, with the roadway centerline approximately 68 feet from the west ROW boundary and approximately 132 feet from the east ROW boundary. There are no known utility or drainage easements in the existing ROW.

## 2.3 Roadway Classification and Context Classification

The roadway is classified as an “Urban Principal Arterial - Other” from Van Buren Parkway to Sand Road and from north of Charlee Road to the Charlotte County Line. It is classified as a “Rural Principal Arterial – Other” from north of Sand Road to south of Charlee Road. Posted speed limits are 50 and 55 MPH, respectively. Burnt Store Road does not have a designated context classification but the Florida Greenbook uses the same system as used for state highways. The project corridor is best classified as C2 – Rural in the current condition. However, as numerous residential and commercial developments are pending, it is anticipated that the corridor will become C3R – Suburban Residential. Burnt Store Road is an emergency evacuation route designated by the Florida Division of Emergency Management and Lee County.

## 2.4 Adjacent Land Use

The majority of the existing land use adjacent to Burnt Store Road include natural areas associated with conservation lands, rangeland, and barren lands associated with inactive mining operations. Low and medium-density residential uses are present toward each end of the corridor. There are very few

commercial land uses (Dollar General, businesses within the Burnt Store Marina) currently. However, there are pending developments in various stages along the corridor. The primary development along the corridor is Burnt Store Marina, which includes single family homes, townhomes, condominiums, a golf course, yacht club, boat club, marina, restaurant and bar, and other supporting infrastructure for these recreational activities. The primary conservation and recreational land uses are associated with Babcock Webb/Yucca Pens Unit Wildlife Management Area, Charlotte Harbor Preserve State Park, Charlotte Harbor Buffer Preserve, and Yucca Pens Preserve. **Figure 2-3** depicts existing land use within the project area.

## 2.5 Horizontal and Vertical Alignments

The existing horizontal alignment contains three horizontal curves (**Table 2-1**). The existing curves are all slight and meet criteria. The vertical alignment is flat due to the flush shoulder; stormwater runs off the pavement to the roadside edges. The profile has only four inches of base clearance in some areas based on the 1954 as-built plans. According to the National Geodatic Survey controls, the roadway profile is at an elevation of 6.5 feet (North American Vertical Datum of 1988 (NAVD 88)) near the southern terminus of the project south of Gator Slough Canal and gradually increases to an elevation of 10.0 feet NAVD 88 at the northern terminus just south of Wallaby Lane.

**Table 2-1: Existing Horizontal Alignment**

Baseline PI Station	Bearing		Degree of Curvature	Length
	Back	Ahead		
385+94.55	N01°57'23"E	N 00° 19' 08" E	00° 20' 00"	491.25 ft
474+24.90	N00°42'28"E	N 02° 52' 38" E	00° 20' 00"	650.83 ft
488+56.56	N02°52'38"E	N 00° 18' 38" E	00° 20' 00"	770.01 ft

Note: The 1954 as-builts did not provide radius information

## 2.6 Pedestrian and Bicycle Facilities

There are no existing pedestrian or bicycle facilities along the majority of the project. However, the recently-constructed four-lane widening of Burnt Store Road to Van Buren Parkway included a shared use path on the northbound side up to 300 feet south of Kismet Parkway, a marked bicycle lane on the northbound side up to Delilah Drive, a marked bicycle lane on the southbound side up to Delilah Drive, and a sidewalk on the southbound side up to NW 21<sup>st</sup> Terrace. The marked bicycle lanes are also on the northbound and southbound bridges over Gator Slough Canal, as is the 10-foot shared use path on the northbound bridge. At the north end of the project, there is sidewalk on the southbound side from Vincent Avenue northward.

## 2.7 Transit Facilities

Public transit (bus) service is not currently provided within the study corridor and there is no future service identified in the Lee County MPO or Charlotte County-Punta Gorda MPO 2045 cost-feasible LRTPs.

## 2.8 Pavement Condition

During early project field reviews, pavement and base failure was noted and attributed to the high water table. Lee County resurfaced the project area in late 2020 as part of routine maintenance.

**Figure 2-3: Existing Land Use Map**

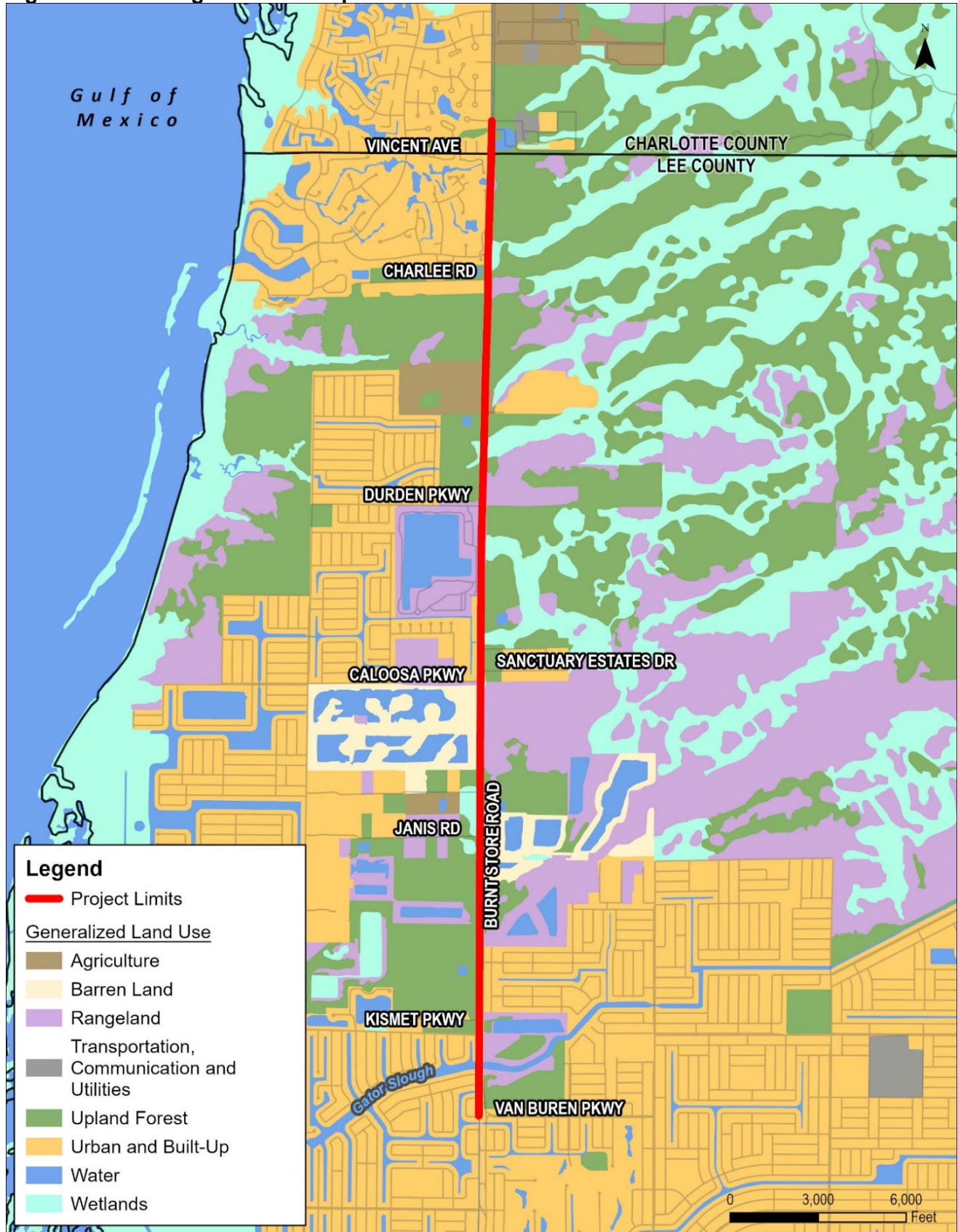

## 2.9 Signalized Intersections

There are no signalized intersections in the immediate project vicinity. The closest signalized intersection is Burnt Store Road and Pine Island Road (SR 78). All intersections within the project limits are three-legged and Two-way STOP-controlled (TWSC) intersections in which the single minor-street approach (i.e., the stem of the T configuration) is controlled by a STOP sign. The existing lane configurations within the project limits are shown in **Figure 2-4**.

## 2.10 Railroad Crossings

There are no railroads within the study limits.

## 2.11 Traffic Volumes and Operational Conditions

This section provides a summary of the existing traffic conditions outlined in the *Project Traffic Analysis Report* (PTAR) (August 2022) prepared for this project. More detailed information on existing daily and peak hour traffic data and operational analysis is provided in the PTAR, included in the project file.

### 2.11.1 Intersection Layout and Traffic Control

All intersections within the project limits are three-legged and Two-way STOP-controlled (TWSC) intersections in which the single minor-street approach (i.e., the stem of the T configuration) is controlled by a STOP sign. The existing lane configurations within the project limits is shown in **Figure 2-4**.

### 2.11.2 Existing (2021) Traffic Volumes

The existing AADT volumes within the project limits range from 9,800 to 14,000 vehicles per day (VPD). For peak hour conditions, traffic data for the study area was collected from February 16, 2021 through February 18, 2021. Count data was examined and the common weekday AM peak hour (7:45 – 8:45 AM) and PM peak hour (3:45 – 4:45 PM) were identified. The existing turning movement counts (TMCs), peak hour factors (PHFs), and heavy vehicle percentages (HVs%) were used as inputs for existing year traffic operational analysis. Volumes were collected during the peak season and no adjustments have been applied. Therefore, existing conditions volumes and existing conditions analyses reflect peak season conditions. **Appendix D** displays the existing TMCs (AM and PM peak) for all study intersections.

### 2.11.3 Existing (2021) Traffic Operational Analysis

Existing traffic operational analyses for AM and PM peak hours were conducted using collected peak hour traffic counts. As the study segment has the characteristics of an arterial roadway, LOS measure for the study segment was developed by comparing the volumes with the threshold volumes from the Link Service Volumes on Arterials developed by Lee County.

The AADT volumes and recommended K (peak-to-daily ratio) and D (directional distribution) factors were used to calculate the Directional Design Hourly Volumes (DDHV) for each segment as shown in **Table 2-2**. Per the approved traffic analysis methodology, the Volume-to-Capacity ratio (V/C) and LOS measures for the study segments were developed by comparing the calculated DDHVs with the threshold volumes from the Link Service Volumes on Arterials developed by Lee County (see **Table 2-3**). Also, per the approved traffic analysis methodology, no intersection operational analyses were performed as part of the study.

Figure 2-4: Existing (2021) Lane Configuration

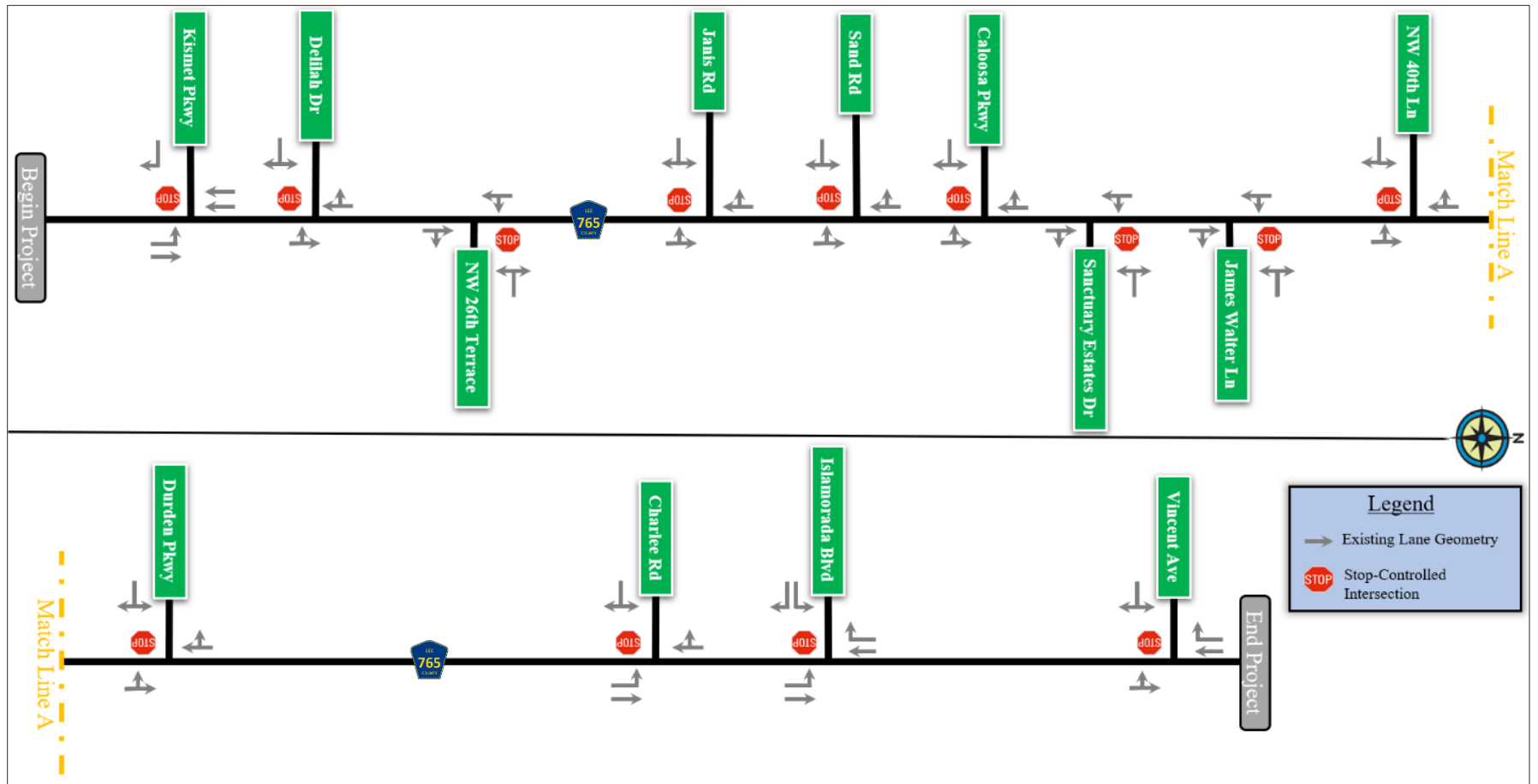



**Table 2-2: Existing (2021) Segment LOS Analysis**

Burnt Store Road Segment	AADT Volume	K*D (0.095 x 0.58)	DDHV	V/C	LOS
Van Buren Parkway to Kismet Parkway	14,000	0.0551	771	0.68	D
Kismet Parkway to Delilah Road	10,500	0.0551	579	0.51	C
Delilah Road to NW 26 <sup>th</sup> Terrace	10,000	0.0551	551	0.48	C
NW 26 <sup>th</sup> Terrace to Janis Road	10,000	0.0551	551	0.48	C
Janis Road to Sand Road	10,000	0.0551	551	0.48	C
Sand Road to Caloosa Parkway	10,000	0.0551	551	0.48	C
Caloosa Parkway to Sanctuary Estate Drive	9,900	0.0551	545	0.48	C
Sanctuary Estate Drive to James Walter Drive	9,800	0.0551	540	0.47	C
James Walter Drive to NW 40 <sup>th</sup> Lane	9,800	0.0551	540	0.47	C
NW 40 <sup>th</sup> Lane to Durden Parkway	9,800	0.0551	540	0.47	C
Durden Parkway to Charlee Road	9,800	0.0551	540	0.47	C
Charlee Road to Islamorada Boulevard	10,500	0.0551	579	0.51	C
Islamorada Boulevard to Vincent Avenue	11,000	0.0551	606	0.53	C

**Table 2-3: Burnt Store Road Link Service Volumes**

Road Type	Level of Service (Peak Hour - Peak Direction)				
	A	B	C	D	E
4-Lane	870	1,490	2,100	2,660	2,950
2-Lane	150	390	640	880	1,140

Source: Link Service Volumes on Arterials developed by Lee County

The V/C ratio makes it possible to estimate the relative level of congestion on a segment of roadway. A roadway is considered over capacity if the V/C ratio is greater than 1.0. In general, a V/C ratio less than 0.85 indicates that adequate roadway capacity is available, and vehicles are not expected to experience significant queues and delays. The results indicate that the operation conditions for all segments under the existing condition are acceptable.

**2.11.4 Crash Data and Safety Analysis**

Crash data was obtained for a five-year period from January 2015 to December 2019, along Burnt Store Road from Van Buren Parkway to the Charlotte County Line. Crash data was examined to determine frequency and type of crashes that had occurred along the corridor.

Based on the crash data (2015-2019), a total of 53 crashes occurred, including one fatality and 15 injury crashes, and no pedestrians/bicyclists involved crashes. **Figure 2-5** displays the crash data by year along with the respective severities.

**Figure 2-5: Crash Summary by Year and Crash Severity**

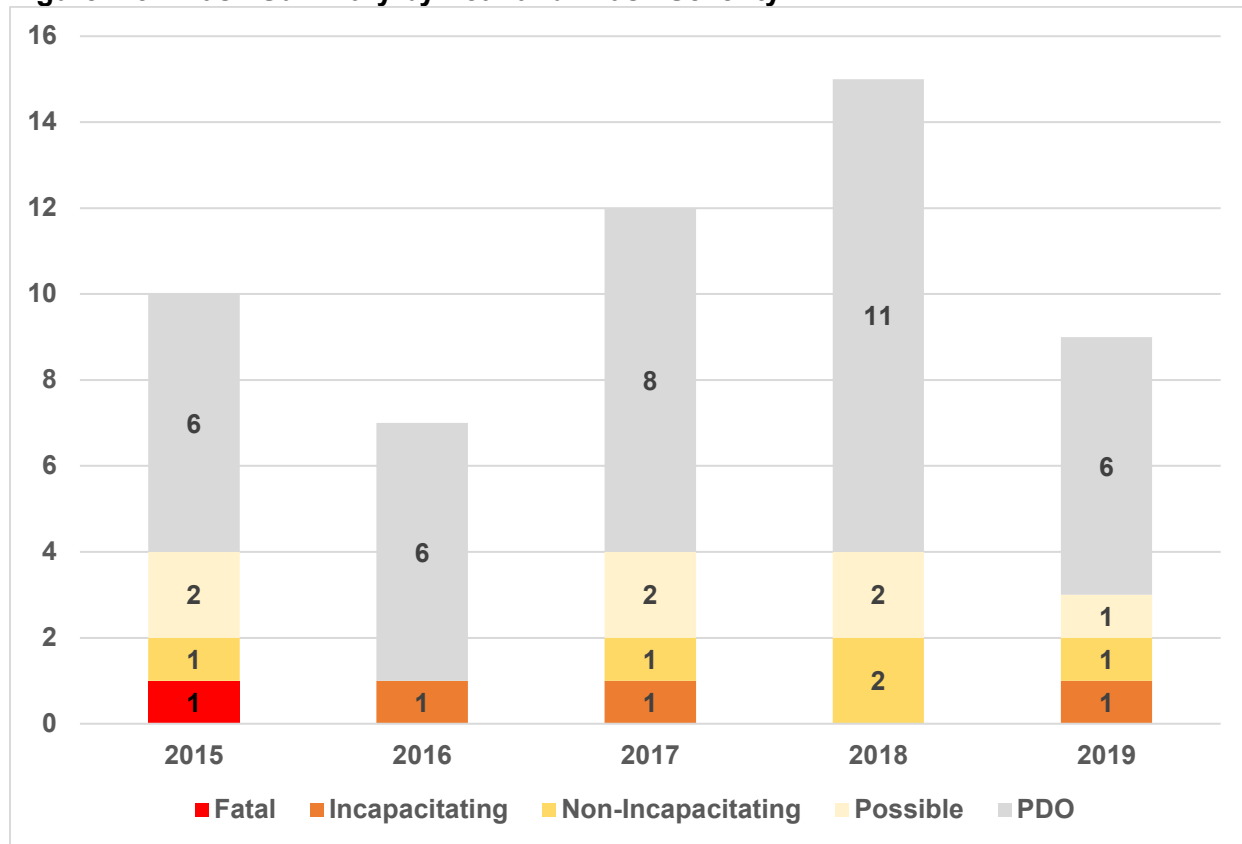

Note: PDO – Property Damage Only

As shown in **Figure 2-6**, the highest crash type observed was rear-end crashes comprising 20.8% of the total crashes, followed by angle crashes (15.1%) and runoff-road crashes (15.1%).

**Figure 2-6: Burnt Store Road Crash Types (2015-2019)**

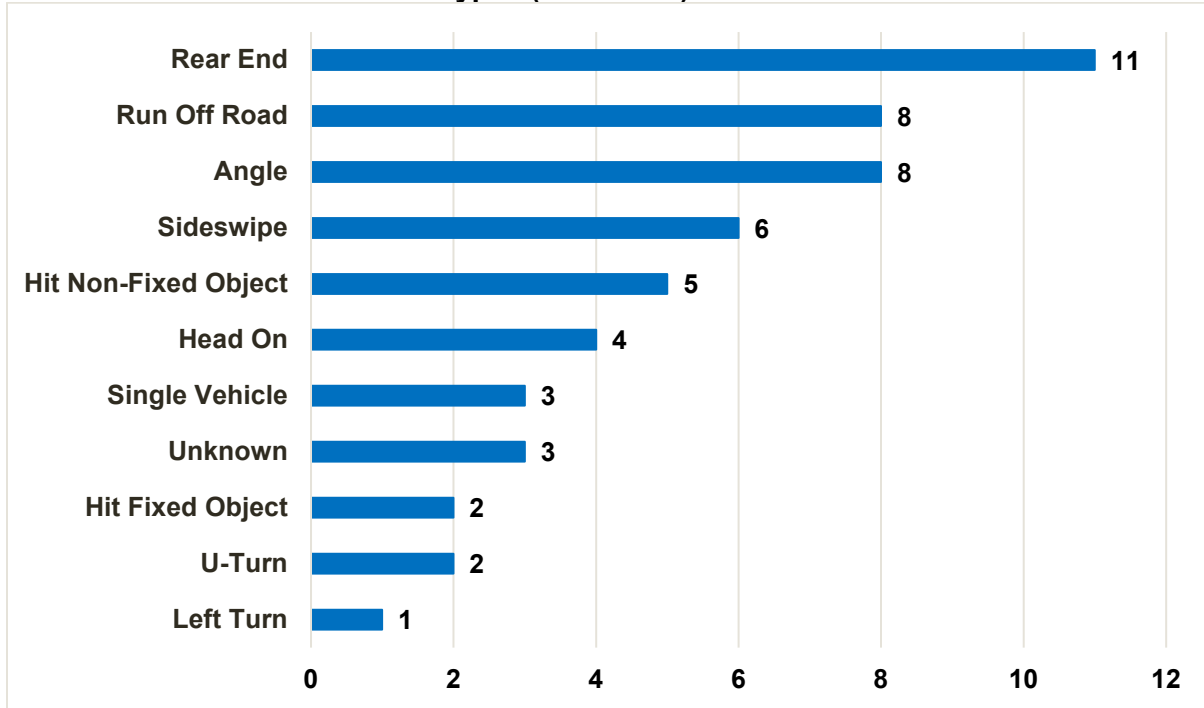

Figure 2-7 displays the crashes during that same five-year period classified by the conditions of the roadway at the time of the crashes. The data indicated that 83.0% of the crashes occurred during dry road surface conditions and 17.0% of crashes occurred during wet surface conditions. The runoff road crashes were mainly due to hydroplaning.

**Figure 2-7: Burnt Store Road Crashes (2015-2019) by Road Surface Condition**

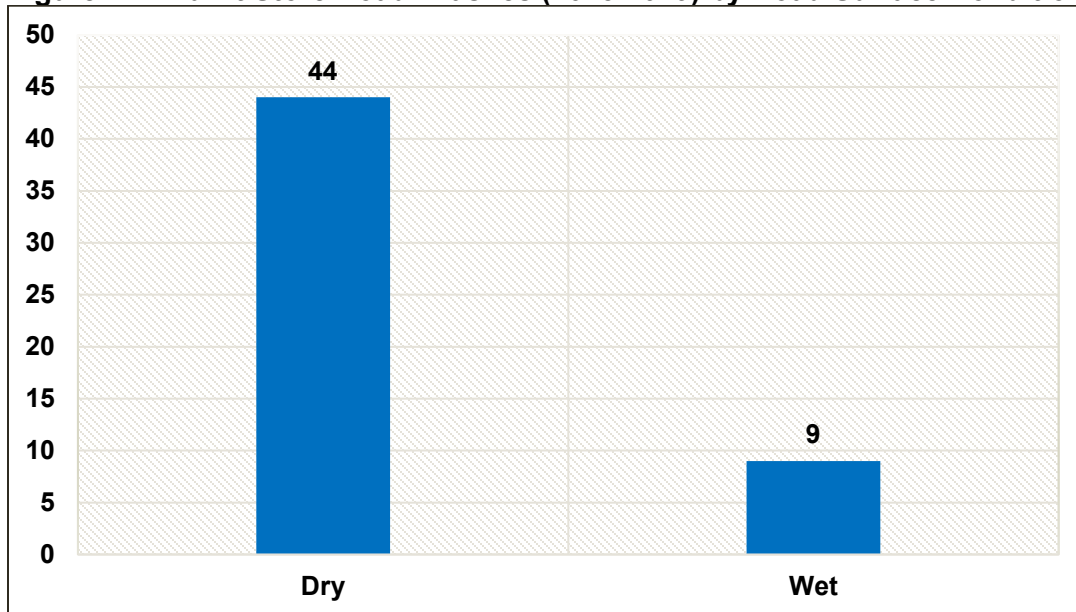
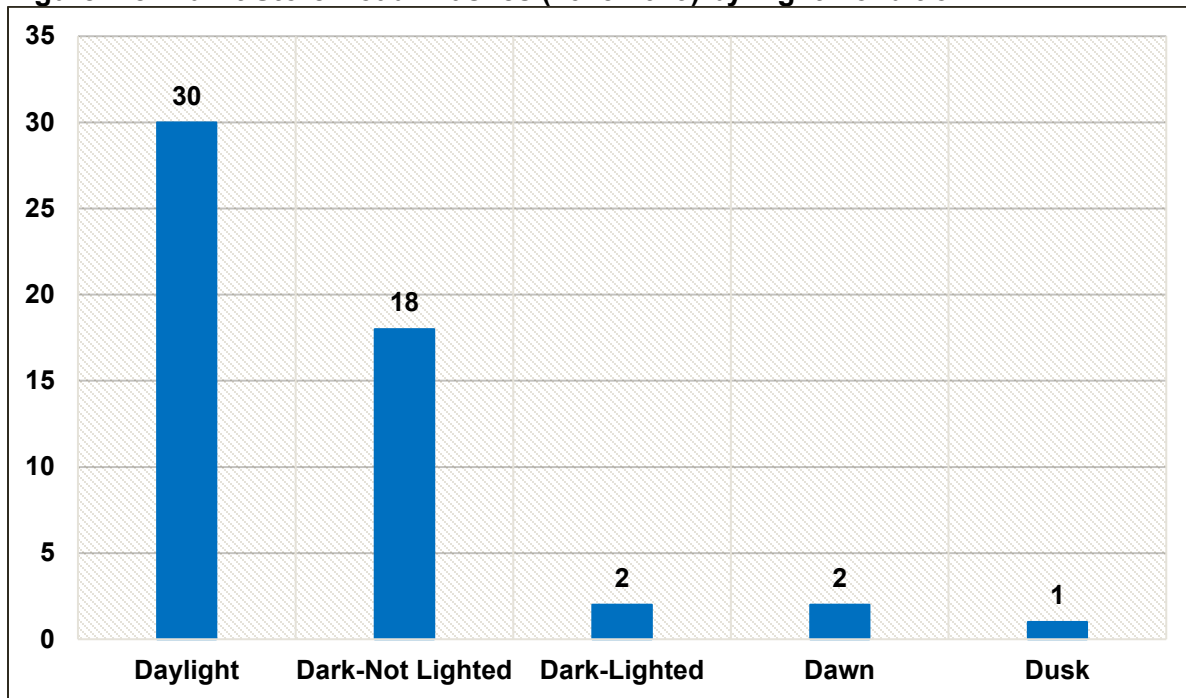

Figure 2-8 presents the crashes by the light condition. The data indicated that 56.6% of the crashes occurred during daylight while approximately 34% occurred during dark-not lighted conditions. Because of the frequency of dark crashes, this corridor may benefit from lighting.

**Figure 2-8: Burnt Store Road Crashes (2015-2019) by Light Condition**



## 2.12 Access Management

Within the project limits, Burnt Store Road is a two-lane undivided arterial facility. Access classes 2 through 7 are associated with arterial facilities; however, Burnt Store Road does not have an assigned access class. Lee County designated the entirety of Burnt Store Road within the county as a controlled access road and established permanent access points for its entirety from Pine Island Road (SR 78) to Vincent Road. This was approved by the Board of County Commissioners on September 15, 2020, as Lee County Resolution No. 20-09-26. Through coordination with Lee County Department of Transportation, it was requested that this access management resolution serve as the basis for intersection design as part of this PD&E Study. The Lee County Access Management Resolution is provided in **Appendix E**.

## 2.13 Drainage

The existing drainage pattern for the project corridor consists of roadway runoff captured by roadside ditches on the east and west side of Burnt Store Road. Stormwater is conveyed to cross drains, which discharge to the west side ditch of Burnt Store Road flowing south and parallel to the road. The west side ditch and a small portion of the east side ditch discharge to Gator Slough and ultimately to Charlotte Harbor. The roadway runoff currently receives no water treatment or attenuation.

A review of FDEP's verified list of impaired waterbodies concluded that the project is within Waterbody Identifications (WBIDs) that are not impaired. However, the project discharges to impaired WBIDs. There

are no adopted TMDLs (Total Maximum Daily Loads) for the WBIDs within the project and they are not part of a Basin Management Action Plan (BMAP). Nutrient loading calculations will be required during the design phase to comply with FDEP and the Water Management District (WMD) design criteria.

According to the Natural Resource Conservation Service (NRCS) Soil Survey most of the project traverses hydrologic soil groups A/D, B/D and C/D. Soils A/D typically exhibit good drawdown capabilities when drained and poor drawdown capabilities when saturated. Soils B/D exhibit moderate drawdown capabilities when drained and poor drawdown capabilities when saturated. Lastly, soils C/D exhibit slow drawdown capabilities when drained and poor drawdown capabilities when saturated.

### 2.13.1 Drainage Basins

Several offsite basins including Yucca Pen Creek, Durden Creek, Greenwell Branch and Gator Slough West sheet flow from east to west, coming in contact with the east roadside ditches of Burnt Store Road. As a result, comingling of roadway runoff and offsite runoff currently occurs. **Table 2-4** identifies the existing drainage basins within the study area.

**Table 2-4: Existing Drainage Basins**

Basin	Begin Station	End Station	Total Area (ac)
1	1291+40	1306+80	6.29
2	1306+80	1342+40	14.55
3	1342+40	1363+60	8.66
4	1363+60	1407+40	17.90
5	1407+40	1457+20	20.35
6	1457+20	1483+20	10.62
7	1483+20	1504+20	8.58
8	1504+20	1523+00	7.68
9	1523+00	1571+20	19.70
10-L	1571+20	1583+20	4.90
10-C	1583+20	1598+00	6.05

Note: L = Lee and C = Charlotte

### 2.13.2 Existing Cross Drains

There are ten cross drains in the project corridor. These cross drains are identified in **Table 2-5**.

**Table 2-5: Existing Cross Drains**

Cross Drain	Barrels	Size	Material	Existing Length (ft)	Station	Notes
CD-2	4	36"	RCP	49	1333+08	
CD-3	2	30"	RCP	53	1347+12	
CD-4	4	24" x 38"	ERCP	85	1380+11	
CD-5	3	30"	RCP	84	1435+11	Greenwell Branch
CD-6	4	24"	RCP	44	1466+08	
CD-7	4	48"	RCP	90	1492+87	Durden Creek
CD-8	2	30"	RCP	47	1507+31	Durden North
CD-9*	2	9' x 8'	Concrete box	62	1538+06	Yucca Pen Creek
CD-10L	1	10' x 5'	Concrete box	42	1582+09	
CD-10C	1	7' x 4'	Concrete box	106	1591+18	Hog Branch

\* Different data sources reference the size of this culvert differently as a 10'x8', 10'x7', and 9'x8'. Field measurements collected during this project measured the structure to be 2- 9' x 8' cells.

Note: Numbers are associated with basin number; L = Lee and C = Charlotte

RCP = reinforced concrete pipe; ERCP = elliptical reinforced concrete pipe

### 2.13.3 Floodplains/Floodways

The Federal Emergency Management Agency (FEMA) identifies flood hazards, assesses flood risk and provides accurate data to guide stakeholders in taking effective mitigation actions which would increase public safety. A review of the FEMA Flood Insurance Rate Maps (FIRM) for the project area indicates that the northern project area mainly lies outside the 100-year floodplain while the southern project area is primarily identified as Zone AE. Additionally, no portions of the project lie within a regulated floodway. **Figure 2-9** depicts the floodplains with the study area (2003/2008 FIRMs). During the course of this PD&E Study, the FEMA FIRMs were updated. **Appendix F** provides a floodplain update memorandum.

### 2.13.4 Regional Hydrological Restoration Goals

The Charlotte Harbor, Gator Slough, and Caloosahatchee River watersheds, which include the Fred C. Babcock/Cecil M. Webb Wildlife Management Area (Babcock Webb WMA), Yucca Pens Unit WMA (Yucca Pens), and numerous creeks that flow into eastern Charlotte Harbor across the Burnt Store Road project area, have been impacted over the past 100 years by man-made changes in hydrology. The Lower Charlotte Harbor Flatwoods Strategic Hydrologic Restoration Plan (Coastal & Heartland National Estuary Partnership (CHNEP), 2022) explains that the conversion of native wetland habitats to agriculture or development, surface mining, and construction of major roadways such as US-41 and I-75, have significantly altered the historic sheet flow from Babcock Webb to Yucca Pens. The *Pond Siting Report* (February 2023) prepared under separate cover, details the physical barriers constructed over the last several decades. As a result, the vast wetland ecosystems within the Charlotte Harbor Flatwoods are susceptible to over-drainage, flooding, habitat changes, water quality degradation, and climate change stressors. In some instances, the rivers and creeks in this area experience too much flow during the wet season and too little flow during the dry season to support associated wetlands and downstream waterbodies. Project field reviews found corroborating evidence, with wetlands and creeks during the majority of the year very dry to the point that historically mapped wetlands appear to be trending to upland communities, however show evidence of water lines and other hydrological indicators which is likely due to short-term “flash flood” conditions.

Figure 2-9: FEMA Floodplain Map

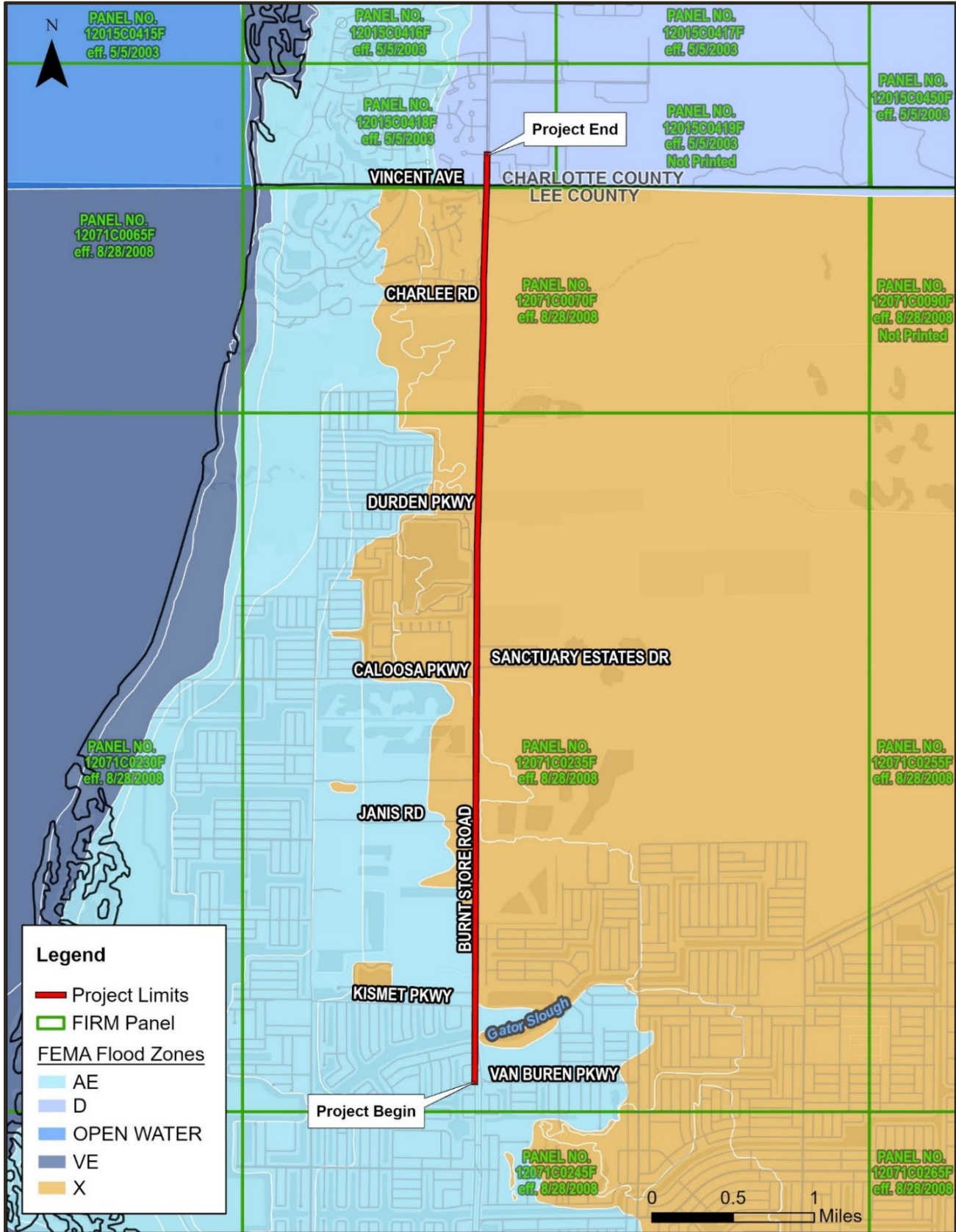

Several studies have been completed to analyze the hydrological degradation and alteration of the area and begin restoration concepts including the South Charlotte County, North Lee County, Babcock/Webb Surface Water Management Concept Plan (2004), Northwest Lee County Surface Water Management Plan (2005), Final Technical Memorandum- Yucca Pens Hydrologic Restoration Plan (2010), Yucca Pens Hydrological Study: A Collaborative Effort for Future Restoration (2018), Hydrogeologic Survey of Yucca Pens Wildlife Management Area to Assist with Charlotte Harbor Flatwoods Hydrologic Restoration Initiative (2019), and most recently, the Lower Charlotte Harbor Flatwoods Strategic Hydrologic Restoration Plan (2022). One restoration project has been constructed, the Matlacha Pass Hydrological Restoration Project, which involved expansion of three culverts under Burnt Store Road within the project limits and two drop structures north of the Gator Slough Bridge. In addition, the Charlotte Harbor Flatwoods Initiative (CHF) was formed to initiate efforts to restore natural drainage with water that has been unnaturally impounded on the Babcock Webb WMA and diverted from the Yucca Pens, Caloosahatchee River, and tidal creeks to Charlotte Harbor. The CHF is comprised of multiple local, state and federal agencies, the CHNEP, and other stakeholders. The PD&E project team communicated with the CHF at their request during the course of the study to share information and to stay apprised of the hydrological restoration project concepts.

The most recent study, the Lower Charlotte Harbor Flatwoods Hydrologic Restoration Planning project, using hydrological modeling, provided recommendations as to the appropriate restoration and management of surface water flow in the study area. In addition to recommendations for further data collection and modeling, the recommendations for improvements including ATV ditch blocks, low-water fords or constructed weirs, partial groundwater seepage barriers, new box culverts and gated weirs on US 41, and the purchase of new properties and construction of impoundments with drainage structures, are all to the east of Burnt Store Road. However, the Burnt Store Road PD&E Study is of interest to the CHF and CNEP teams since some flows from this large area are directed to Hog Branch, Yucca Pen Creek, Durden Creek and Durden North Branch, Greenwell Branch and Gator Slough Canal. Study models for three project scenarios showed that in the potential post-restoration project conditions, peak condition flows through the cross drains under Burnt Store Road would be less than flows in the baseline existing conditions scenario. This is a desired outcome as water would be retained within the Yucca Pens and adjacent lands for longer periods. Additionally, the recession limb of the flow after each storm event would be extended as desired due to the restoration measures, with extended duration of positive discharges from Yucca Pens WMA to tidal creeks during the dry season.

Lee County expressed interest in alternative drainage concepts such as using the adjacent conservation parcels for stormwater management. For example, a spreader-swale type system could benefit the eastern conservation lands by directing water to these lands from the roadway. If this additional water from the roadway were modeled over the large basin, it is expected that it would be a very small net increase and the property managers and CHF team would be supportive of this concept. An enhancement concept could be the addition of a berm on the west side of Burnt Store Road, downstream of these properties, to assist with compensating volumetric storage.

Further, compensatory treatment on these adjacent conservation lands could be explored. A small depth of water could be stored on the conservation areas to provide the required treatment and also meet the attenuation requirements. The South Florida Water Management District (SFWMD) indicated in a project



pre-application meeting that this upland water storage concept would be a viable treatment and attenuation alternative, with as much pre-treatment as feasible prior to discharge.

In addition, the north branch of Yucca Pen Creek, in the vicinity of what is now Charlee Road, was severed several decades ago by road and housing construction. The Florida Fish and Wildlife Conservation Commission (FWC) is examining the feasibility of restoring the north branch flows by potentially reestablishing flow under Burnt Store Road at the location of the historical north branch with a new culvert or low water crossing. This route, however, interfaces with Charlee Road and residential parcels (with constructed homes) on the west side of Burnt Store Road, before continuing eastward in the Charlotte Harbor Preserve State Park property. Towards the outfall to the bay, the stream runs closely adjacent to additional home sites. A less ideal concept from the hydrological restoration perspective is to route flows from the north branch southward, to the existing Yucca Pen Creek bridge culvert. While a new crossing or a modified branch connection could be considered during the final design phase, a downstream flood study would be necessary as it is important to ensure that off-site drainage will not cause flooding to adjacent and downstream properties. The South Florida Water Management District will not permit a concept that cannot demonstrate that downstream properties will be unaffected.

As the area-wide restoration modeling and projects progress, and as the final design phase of this project begins and more detailed data is collected, the CHFI can coordinate with Lee County for any collaborative project opportunities. Lee County may also choose to further explore the alternative drainage concepts previously described, once detailed topographic data and drainage modeling is available, to offset the number and size of off-site stormwater management facilities.

## **2.14 Soils and Geotechnical Data**

Published information from the Florida Department of Environmental Protection show this site located within Shelly sediments of Plio-Pleistocene Age (TQsu). This consists of shelly sands and carbonates that when mapped together are equivalent to the Okeechobee Formation. Lithologically these sediments are complex, varying from unconsolidated, variably calcareous and fossiliferous quartz sands to well indurated, sandy fossiliferous limestones. Clayey sands and sandy clays are present. These sediments form part of the surficial aquifer system.

The soil types that occur along the project were determined using the Natural Resource Conservation Service (NRCS) data. Common soils include Wabasso Sand, Wabasso Sand-Urban Land Complex, Oldsmar Sand, Oldsmar Sand-Urban Land Complex, Pineda-Pineda Wet Fine Sand, Pineda Fine Sand-Urban Land Complex, Matlacha Gravelly Fine Sand, Limestone Substratum, Myakka Fine Sand- Urban Land Complex, Malabar Fine Sand, Brynwood Fine Sand, Wet, and Immokalee Sand. There has been a historical shift of soil properties throughout the extent of the project area from hydric soils to more non-hydric soils. This suggests a reduction in wetland habitats in the project area.

The depths to the groundwater table ranged from existing ground surface to three feet below the existing ground surface. Groundwater conditions vary with environmental variations and seasonal conditions, such as the frequency and magnitude of rainfall patterns, as well as man-made influences (i.e., existing water management canals, swales, drainage ditch, underdrains and areas of covered soils, such as paved parking lots and sidewalks). The estimated seasonal high groundwater table levels at these locations ranged from the existing ground surface to approximately one foot below the existing ground

surface. In general, the estimated seasonal high groundwater table levels were based on soil stratigraphy, measured groundwater levels from the borings, Lee County, Florida USDA Soil Survey information, and experience with similar soil conditions.

## 2.15 Structures

There are three bridge structures along Burnt Store Road within the study limits. **Table 2-6** provides a summary of the existing bridge structures.

**Table 2-6: Existing Roadway Bridges**

Bridge Number	Location	Approx. Bridge Length (ft)	Year Built/Reconstructed	Sufficiency Rating	Health Index
120025	SB Burnt Store Road over Gator Slough Canal	6 x 26' = 156'	1972	86.2	90.99
124140	NB Burnt Store Road over Gator Slough Canal	3 x 76.08' = 228.25'	2017	97.4	98.44
120054*	Burnt Store Road over Yucca Pen Creek (Bridge Culvert)	2 - 9' x 8' x 40'	1965	91	67.95

\* Different data sources reference the size of this culvert differently as a 10'x8', 10'7", and 9'x8'. The 9' x 8' dimensions are listed as referenced in the bridge inspection reports and project field measurements. To be conservative, the drainage hydraulics analysis used a size of 10'x7'.

The summary of existing conditions prepared for the bridges indicated above are based on the most recent above water and underwater inspection reports and construction plans available.

**Bridge No. 120025 (Southbound Burnt Store Road over Gator Slough Canal):** Built in 1972, the owner of the bridge is Lee County. The superstructure is comprised of prestressed concrete slab units (12" thick) with asphalt overlay (up to 3" thick, original thickness 1½" to 1⅝"). The prestressed slab units are laterally post-tensioned. There are six spans 26' long for the total length of 156'. The bridge deck has no skew. The bridge width between the gutter lines is 40'. The deck carries two 11'-0" lanes and 9'-0" shoulders. The shoulder along the west side is also marked as a bike lane. The deck has substandard railing comprised of concrete post and beam railings. The total deck width is 42'-3" and the deck is sloped toward the west at ¼" per foot. There are scuppers along the west gutter line. The concrete post and beam railings are connected to the guardrails at the begin/end bridge. The structure is not posted for load. The Bridge Inspection Report dated August 31, 2021 states that the load rating from November 21, 1995 appears complete and applicable. The condition of the superstructure is classified as "Fair".

The substructure is comprised of seven bents: end bents have 3'-5" x 2'-6" reinforced concrete caps and intermediate bents have 2'-8" x 2'-6" reinforced concrete caps with six 18" prestressed concrete piles each. The end bents and the intermediate bents piling is plumb except the outside piles on the intermediate bents are battered (2" per 12"). The 20'-0" approach slabs are asphalt covered. The abutments are enveloped with tied-back reinforced concrete sheet piling. The condition of the substructure is classified as "Good." **Figure 2-10** depicts the existing bridge typical section for Bridge Number 120025.

**Figure 2-10: Existing Bridge Typical Section (Bridge No. 120025)**

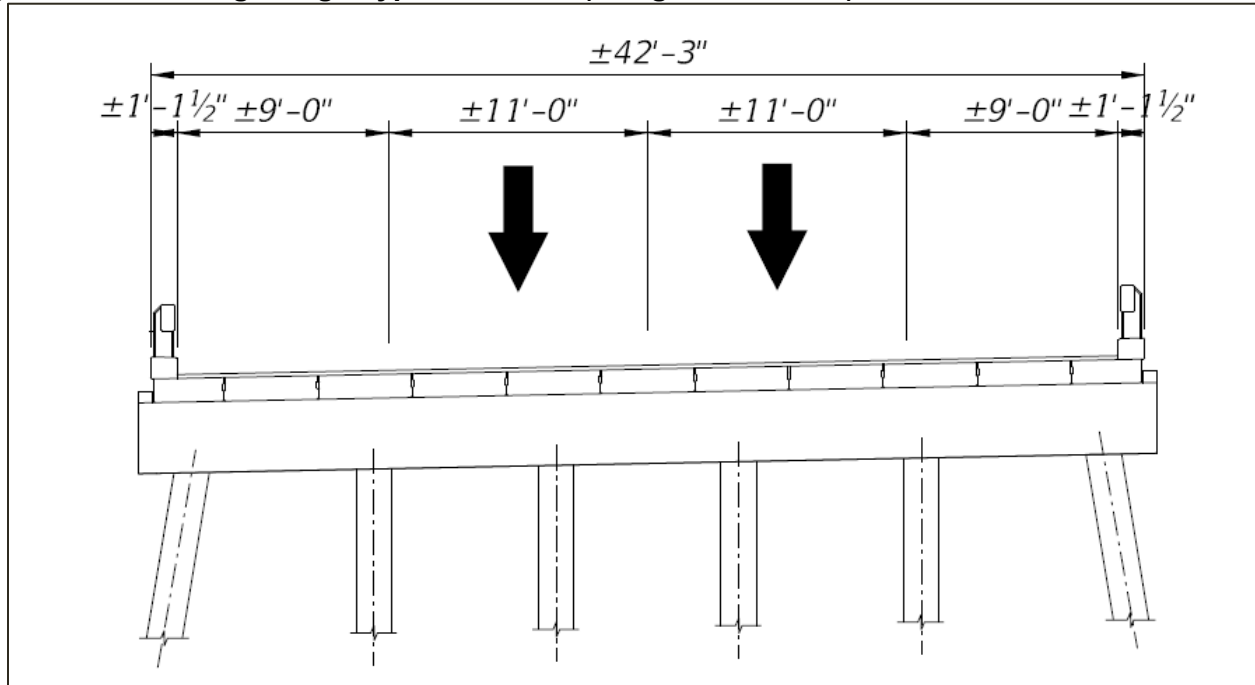

**Bridge No. 124140 (Northbound Burnt Store Road over Gator Slough Canal):** Built in 2017, the owner of the bridge is Lee County. The bridge superstructure is comprised of six American Association of State Highway and Transportation Officials (AASHTO) Type IV prestressed concrete beams with 8½" thick reinforced concrete deck. The bridge has three spans of 76'-1" for a total length of 228'-3". The bridge deck has no skew. The bridge width between the gutter lines is 48'-6". The roadway portion of the deck is protected by 32" F-shape traffic railings (1'-6" wide). The deck has two 11'-0" lanes, 16'-6" shoulder along the west side and 10'-0" along the east side of the travel lanes. The 10'-0" shoulder is also marked as a bike lane. Along the east side of the deck, there is 10'-0" sidewalk with a pedestrian parapet consisting of an aluminum triple bullet railing. No posting of the structure is proposed. The condition of the superstructure is classified as "Very Good". The 30'-0" approach slabs are asphalt covered. The abutments are enveloped with tied-back reinforced concrete sheet piling.

The substructure is comprised of four bents: end bents have 4'-0" x 3'-6" reinforced concrete caps and intermediate bents have 4'-0" x 3'-0" reinforced concrete caps with six 24" prestressed concrete piles each. End bent and intermediate bent piles are plumb. The condition of the substructure is classified as "Very Good". **Figure 2-11** depicts the existing bridge typical section for Bridge Number 124140.

**Figure 2-11: Existing Bridge Typical Section (Bridge No. 124140)**

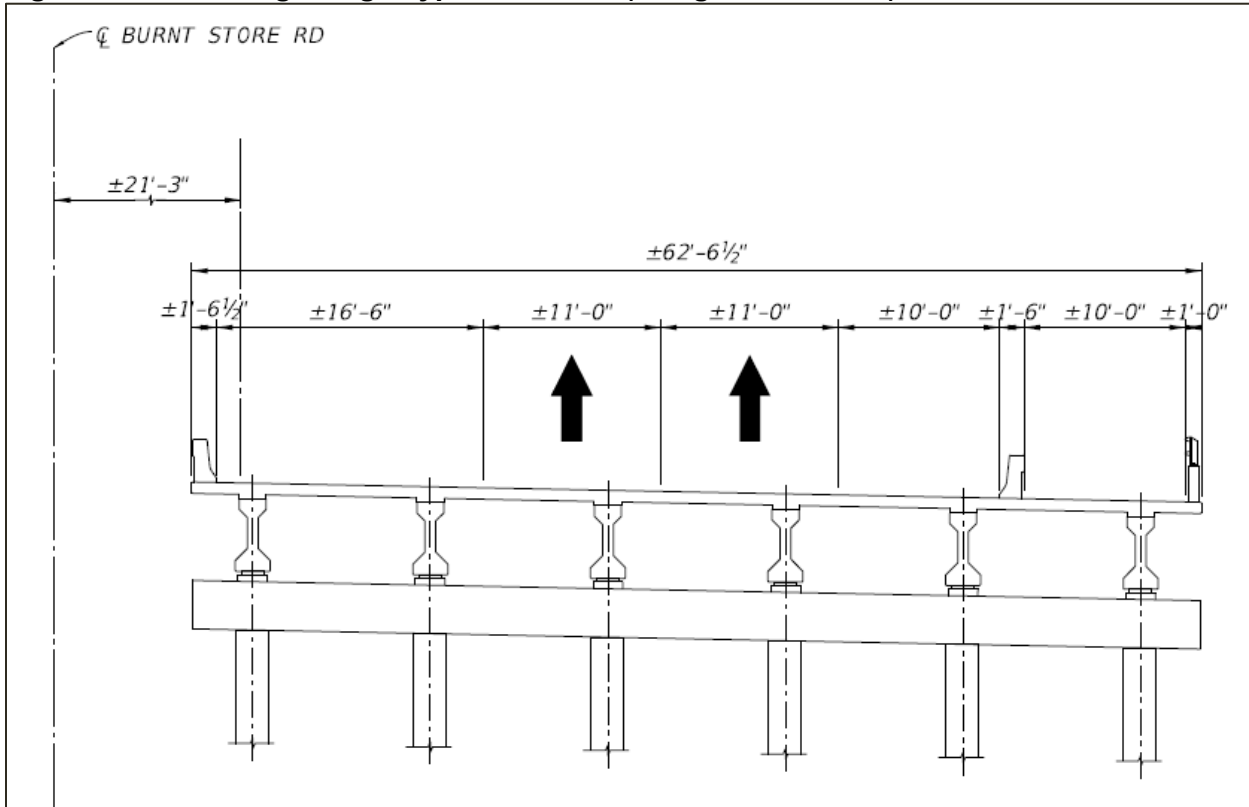

**Bridge No. 120054 (Burnt Store Road over Yucca Pen Creek):** This bridge culvert was built in 1965 and it is owned by Lee County. This bridge culvert structure is comprised of two 10' x 8' cells. The Bridge Inspection Report states that the height of the cells is 9'. The reduction in the cross section is probably due to applied shotcrete. The length of the culvert is 40'-0". There are two 11'-0" lanes carried by the culvert over the creek, with 5'-0" unpaved shoulders on either side. The asphalt thickness is estimated at 4" and the fill depth at 1'-0" over the top culvert concrete slab (11¼" thick). The exterior walls and the interior wall are 8" thick. The cell walls from the ceiling to floor slab are coated with shotcrete repair. At either culvert mouth, there are wingwalls at a 45° skew to the centerline of the culvert. The wingwalls are coated with a sound shotcrete repair. The structure is not posted for load. The toes of the floor slab are lined with rock rubble. **Figure 2-12** depicts the existing bridge typical section for Bridge Number 120054.

**Figure 2-12: Existing Bridge Typical Section (Bridge No. 120054)**

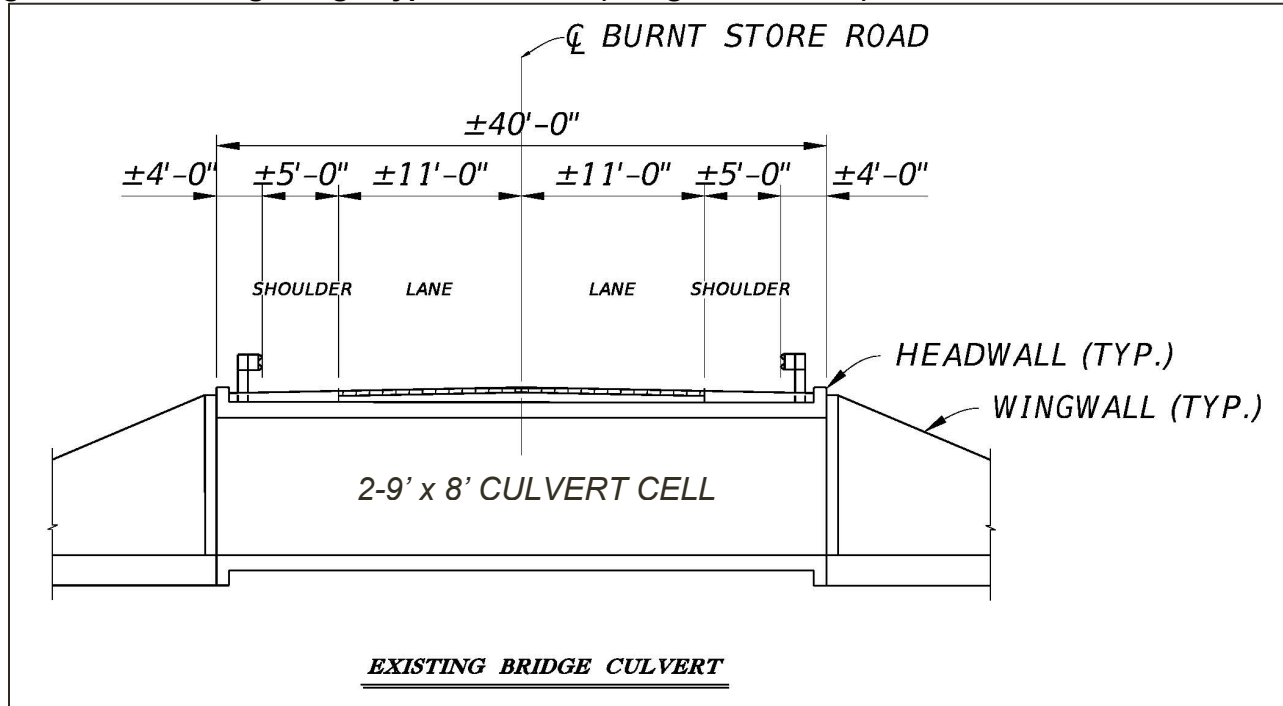

**Miscellaneous Structures – Culverts:** There are ten cross drain culverts along the corridor, previously summarized in **Table 2-5**.

### 2.16 Navigable Waterways

Gator Slough is considered a navigable waterway west of Burnt Store Road for small recreational vessels, but it is not navigable to the east due to the presence of a flood control structure that is managed by the SFWMD.

### 2.17 Utilities

Base maps were sent to utility providers in accordance with Part 2, Chapter 21 of the FDOT PD&E Manual with a request to provide information on existing and planned utilities within the project area. Correspondence and sketches of the existing and planned utilities are included in the project file and compiled into a *Utility Assessment Package* (August 2022), prepared under separate cover. **Table 2-7** summarizes utility type, location and name of utility company/owner.

The following utility owners were identified through the Sunshine State One Call of Florida (Sunshine 811) but were confirmed to have no presence within the project limits: City of Cape Coral Utilities, Greater Pine Island Water Association, Inc., Lee County Utilities, and Broadstar/MDU Pro.

### 2.18 Lighting

Existing roadway lighting within the Burnt Store Road corridor study limits is limited to both ends of the corridor, where the existing four-lane sections transition to the two-lane section located in the study limits. This includes light emitting diode (LED) lighting from north of Van Buren Parkway to Delilah Drive and from Vincent Avenue to the four-lane section in Charlotte County. There are three electric pole-mounted

high-pressure sodium (HPS) cobra head lights located on the west side, along the Burnt Store Marina development. Lee County maintains the lighting on the south end of the project limits and Charlotte County maintains the lighting on the north end of the project.

**Table 2-7: Existing Utility Owners**

Company	Contact	Utilities
Charlotte County Lighting District	Andrew Amendola (941) 575-3648 or (941) 628-9301 Andy.Amendola@charlottecountyfl.gov	Buried electric on west side in Charlotte Co. and on east side at very northern limit in Charlotte Co.
Charlotte County Utilities	Hendrik Dolleman (941) 286-7198 or (941) 883-3521 Hendrik.Dolleman@charlottecountyfl.gov	Buried water, wastewater, and reclaimed water mains on west side from 40 <sup>th</sup> Street to north end of project and crossing road and on east side at northern limit in Charlotte Co.
Comcast	Steve Hutson (239) 672-1171 steve_hutson@comcast.com	Overhead cable on electric poles on west side and on several side streets to the west; buried cable on west side in several locations and crossing road at northern limit in Charlotte Co.
Crown Castle Fiber	Danny Haskett (786) 610-7073 or (786) 246-7827 Danny.Haskett@crowncastle.com	Overhead fiber on electric poles on east side at northern limit in Charlotte Co.; buried fiber on west side at south end, crosses road in two locations, and on east side at northern limit in Charlotte Co.
Florida Power and Light	Chris McJunkin (941) 423-4833 Chris.McJunkin@FPL.com	Overhead electric crosses road just north of Vincent Ave. and at Wallaby Ln. and runs on east side to the north project limit (Charlotte Co.)
Lee County Electric Cooperative	Keith Lanman (239) 656-2414 or (239) 281-6265 Keith.Lanman@lcec.net	Overhead electric on west side with road crossings in several locations; buried electric on west side at Islamorada Blvd.
Lee County Signal Department	Ryan Kirsch (239) 533-9512 RKirsch@leegov.com	Buried electric on east and west sides from southern project limit to Delilah Dr.
Lumen (previously CenturyLink)	Ezekiel Reid (239) 791-1299 Ezekiel.Reid1@lumen.com	Utility parcel with building/hub on east side just north of Lee County Line; buried fiber optic on west side at south and north ends of project; several roadway crossings; overhead telephone on west side in several locations; buried telephone on majority of west side with crossings in two locations

## 2.19 Signage

There are no overhead signs within the project limits. Any signage along the corridor is related to regulatory signage (i.e., speed limit, STOP sign, etc.).

## **2.20 Existing Environmental Features**

There are several state and county managed conservation areas that border the corridor, including Yucca Pens Preserve, Charlotte Harbor Buffer Preserve, Babcock-Webb Yucca Pens Unit Wildlife Management Area (WMA), and Charlotte Harbor Preserve State Park. Babcock-Webb Yucca Pens Unit WMA was historically disturbed for agriculture and has been restored with continuous invasive plant removal, hydrologic improvements, pine tree thinning, and prescribed burns. There are several privately-held parcel “gaps” in the preserve properties that agencies have targeted for potential future acquisition. There are also two conservation easements on private property, the first located on parcel Nos. 294323C1000010020 and 294323C1000010030 (2901 Burnt Store Road N) and the second located on parcel No. 08432300000020000 (4751 Burnt Store Road N). These conservation easements were required by SFWMD as mitigation for wetland impacts caused by extraction activities associated with North Oaks Mine and Burnt Store Acres Borrow Pit, respectively.

## **2.21 Aesthetic Features**

There are no aesthetic features within the existing ROW. Along the east side of the Burnt Store Marina development, just outside of the roadway ROW, there is a privately-owned, decorative privacy wall and landscaping. This is located from approximately south of Islamorada Boulevard to Vincent Avenue. The Burnt Store Marina Homeowners Association is responsible for maintaining these features.

## 3.0 PROJECT DESIGN CONTROLS AND CRITERIA

---

### 3.1 Roadway Context Classification

Burnt Store Road does not have a designated context classification but the Florida Greenbook uses the same system as used for state highways. The project corridor is best classified as C2 – Rural in the current condition. However, as numerous residential and commercial developments are pending, it is anticipated that the corridor will become C3R – Suburban Residential.

### 3.2 Design Control and Criteria

The design criteria used for this project is provided in **Table 3-1**. The Preferred Alternative requires a variation for lane width based on the design speed of 50 MPH. The proposed 11-foot lane width allows for other proposed improvements to be constructed within the existing ROW, such as the 10-foot wide shared use paths on each side and the bicycle lanes. Narrower travel lanes also promote lower operating speeds which help reduce crash severity. The median width transitions to 22-feet with inside curb in the ultimate six-lane condition which would require a design variation. Similarly, the six-lane condition would require a variation for lane width. However, a reduction in speed from 50 MPH to 45 MPH at that time would eliminate the need for design variations.



**Table 3-1: Roadway Design Criteria**

Design Element		Value	2018 Florida Greenbook*	Comments	
Typical Section	Context Classification	C2 - Rural	uses same system as for state highways	Context classification not formally designated	
	Design Speed	50 MPH	Table 3-1		
	Lane Widths	12-ft	Table 3-20	Requires Design Variation	
	Minimum Median Width	30-ft	Table 3-23	Requires Design Variation for ultimate 6-lane typical section	
	Cross Slope	2% (3% outside lane)	Chapter 3, Section C.7.b.2		
	Shoulder Cross Slope (%)	6%	Table 3-22		
	Shoulder Width	Inside (Paved)	6-ft (0-ft)	Table 3-21	Ultimate 6-lane typical section; use 7-ft paved outside shoulder per Lee County direction
		Outside (Paved)	10-ft (7-ft)		
Clear Zone Width/ Recoverable Terrain		20-ft (1:6 or flatter), 24-ft (1:4)	Table 4-1		
Horizontal	Minimum Stopping Sight Distance (Flat $\leq$ 2%)	425-ft	Table 3-4		
	Maximum Deflection without Curve (With Curb & Gutter)	0° 45' 00"	Chapter 3 Section C.4.b		
	Length of Curve	Desirable	750-ft	Table 3-8	
		Minimum	400-ft		
	Maximum Superelevation		10%	Table 3-10	
	Maximum Curvature (e=NC)		8337-ft	Table 3-10	
Maximum Curvature (e max=0.10)		2292-ft	Table 3-10	Use maximum 5%	
Vertical	Min. Vertical Clearance for Roadway over Roadway	16.5-ft	Chapter 3 Section C.7.j.4.(b)		
	Maximum Grade (Flat Terrain)	6%	Table 3-16		
	Maximum Change in Grade without Vertical Curve	0.6%	Table 3-17		
	Base Course Clearance Above Water Elevation		3-ft	FDM 210.10.3	FDM criteria used because the Florida Greenbook does not identify base clearance requirements
	Crest Curve	K Value	84	Table 3-18	
		Minimum Length	300-ft	Table 3-18	
	Sag Curve	K Value	96	Table 3-18	
		Minimum Length	200-ft	Table 3-18	
Shared Use Path	Design Speed	18 MPH	Chapter 9 Section C.3		
	Paved Width (ft)	10-ft (West), 12-ft (East)	Chapter 9 Section C.1	Trail widths per Lee County direction	
	Max. Grade (Flat Terrain)	5%	Chapter 9 Section C.5		
	Horizontal Clearance	2-ft (min) >3-ft (preferred)	Chapter 9 Section C.1		
	Max. Curvature (Cross Slope = +2%)	74-ft	AASHTO Bicycle Facilities Section 5.2.5	AASHTO Guide for the Development of Bicycle Facilities 2012	
	Max. Curvature (Cross Slope = -2%)	86-ft			
	Separation from Roadway		5-ft	Chapter 9 Section C.2	

Note: \* 2023 Florida Greenbook has not been formally approved as of the time of this document

## 4.0 ALTERNATIVES ANALYSIS

The objective of the alternatives analysis process is to identify technically and environmentally sound alternatives that meet the purpose and need of the project, are acceptable to the community, minimize impacts on the environment, and are cost effective. The process results in the selection of a Preferred Alternative, which can be advanced to the design phase. This section summarizes the alternatives considered and the results of the alternatives evaluation.

### 4.1 Previous Planning Studies

The Bi-County Study of Burnt Store Road- Veterans Parkway to Colonial Boulevard was completed in 2005. This included a Phase I- Report of Data Collection, Existing Conditions, and Future Travel Demand; Phase II- Concept Report; and a Financing Analysis Technical Report. Conceptual designs were developed for the project corridor based on anticipated growth and traffic forecasts. Input was provided by agency staff, elected officials, and the community. Typical sections and corridor alignment alternatives were developed considering design criteria and access management standards. Impacts, project cost, and ROW needs were evaluated. The segment of Burnt Store Road from Van Buren Parkway to the Charlotte County Line was recommended for widening to a four-lane rural typical section with frontage roads by 2015.

### 4.2 Future Traffic Conditions

The *Project Traffic Analysis Report* (August 2022) documents the operational and safety analysis conducted for the PD&E study. The future years of analysis include both opening year (2025) and design year (2045). No analysis for interim year was expected for this project. Per the FDOT’s direction, the link level analyses were included in the PTAR, and no future intersection analyses were evaluated.

**Table 4-1** summarizes the recommended growth rates which were used in the future traffic volumes development process for this project.

**Table 4-1: Recommended Annual Growth Rates**

Roadway	Recommended Annual Linear Growth Rate
<b>Mainline</b>	
Burnt Store Road	5.5% for “No-Build” Alternative 8.2% for “Build” Alternative
<b>Side Streets</b>	
All Side Streets	2.7% for both “No-Build” and “Build” Alternatives

**Appendix D** includes the approved future turning movement volumes for the No-Build opening year (2025), No-Build design year (2045), Build opening year (2025) and design year (2045) study intersections.

### 4.3 No-Build Alternative

Under the No-Build Alternative, Burnt Store Road would remain as a two-lane undivided roadway through the design year 2045 with only routine maintenance being conducted. The traffic analysis for the No-Build Alternative indicates that Burnt Store Road would be expected to operate at an unacceptable LOS

without the proposed widening. All future AADT volumes were linearly projected using a recommended annual growth rate of 5.5% for the No-Build Alternative, then rounded using the AASHTO rounding convention. The AADT volumes, the DDHV, V/C ratio, and LOS for each segment for the opening year and the design year are provided in **Table 4-2** and **Table 4-3**, respectively.

**Table 4-2: No-Build Opening Year (2025) Segment LOS Analysis**

Burnt Store Road Segment	AADT Volume	K*D (0.095 x 0.58)	DDHV	V/C	LOS
Van Buren Parkway to Kismet Parkway	17,000	0.0551	937	0.82	E
Kismet Parkway to Delilah Road	13,000	0.0551	716	0.63	D
Delilah Road to NW 26 <sup>th</sup> Terrace	12,000	0.0551	661	0.58	D
NW 26 <sup>th</sup> Terrace to Janis Road	12,000	0.0551	661	0.58	D
Janis Road to Sand Road	12,000	0.0551	661	0.58	D
Sand Road to Caloosa Parkway	12,000	0.0551	661	0.58	D
Caloosa Parkway to Sanctuary Estate Drive	12,000	0.0551	661	0.58	D
Sanctuary Estate Drive to James Walter Drive	12,000	0.0551	661	0.58	D
James Walter Drive to NW 40 <sup>th</sup> Lane	12,000	0.0551	661	0.58	D
NW 40 <sup>th</sup> Lane to Durden Parkway	12,000	0.0551	661	0.58	D
Durden Parkway to Charlee Road	12,000	0.0551	661	0.58	D
Charlee Road to Islamorada Boulevard	12,000	0.0551	661	0.58	D
Islamorada Boulevard to Vincent Avenue	13,500	0.0551	744	0.65	D

**Table 4-3: No-Build Design Year (2045) Segment LOS Analysis**

Burnt Store Road Segment	AADT Volume	K*D (0.095 x 0.58)	DDHV	V/C	LOS
Van Buren Parkway to Kismet Parkway	32,500	0.0551	1,791	1.57	F
Kismet Parkway to Delilah Road	24,500	0.0551	1,350	1.18	F
Delilah Road to NW 26 <sup>th</sup> Terrace	23,000	0.0551	1,267	1.11	F
NW 26 <sup>th</sup> Terrace to Janis Road	23,000	0.0551	1,267	1.11	F
Janis Road to Sand Road	23,000	0.0551	1,267	1.11	F
Sand Road to Caloosa Parkway	23,000	0.0551	1,267	1.11	F
Caloosa Parkway to Sanctuary Estate Drive	23,000	0.0551	1,267	1.11	F
Sanctuary Estate Drive to James Walter Drive	22,500	0.0551	1,240	1.09	F
James Walter Drive to NW 40 <sup>th</sup> Lane	22,500	0.0551	1,240	1.09	F
NW 40 <sup>th</sup> Lane to Durden Parkway	22,500	0.0551	1,240	1.09	F
Durden Parkway to Charlee Road	22,500	0.0551	1,240	1.09	F
Charlee Road to Islamorada Boulevard	24,500	0.0551	1,350	1.18	F
Islamorada Boulevard to Vincent Avenue	25,500	0.0551	1,405	1.23	F

The advantages of the No-Build Alternative include the following:

- No associated design, construction, or ROW acquisition costs;
- No impacts to the traveling public due to construction; and
- No impacts to the natural and human environments.

The disadvantages of the No-Build Alternative include the following:

- Is not consistent with the purpose and need for the project or with local transportation plans;
- Does not provide for improved multi-modal accommodations for bicycles and pedestrians;
- Increased traffic congestion along the corridor;
- Increased potential for crashes due to congestion and intersections;
- Increased evacuation and emergency vehicle response times; and
- Increased vehicle emission pollutants due to higher levels of traffic congestion.

The No-Build Alternative will remain a viable alternative throughout the PD&E study.

#### **4.4 Transportation Systems Management and Operations**

Under a Transportation System Management and Operations (TSM&O) Alternative, operational improvements are designed to maximize the efficiency of the existing facility. TSM&O alternatives generally include intersection operational improvements such as lengthening or adding lanes to existing turn lanes, changing traffic signal phasing and timing, and access management such as closing or

modifying existing median openings. While the additional capacity needed to address project future year traffic volumes would not be met through the implementation of TSM&O improvements, the Access Management Resolution adopted by Lee County and which designates Burnt Store Road as a controlled access road, will serve as the access management plan for the corridor as part of the build alternatives.

#### **4.5 Alternative Corridors**

Constructing a new roadway in a corridor outside the existing Burnt Store Road corridor would result in significant environmental impacts and/or residential relocations and an overall cost that would be prohibitive. Based on the analysis of the surrounding area, the existing Burnt Store Road corridor is the only viable corridor for the proposed alternatives.

#### **4.6 Corridor Analysis**

The objective of the corridor analysis process is to identify viable corridors in which technically and environmentally sound alignment alternatives can be developed. In consultation with Lee County, no viable corridor alternative to the existing Burnt Store Road corridor was identified or considered for the proposed improvements outlined in this study.

#### **4.7 Build Alternative**

Under the Build Alternative, Burnt Store Road within the project limits was evaluated as a four-lane divided facility. Also, the Access Management Resolution developed by Lee County was followed to include the proposed access points within the project corridor under the Build Alternative. Since the Lee County Access Management Resolution designates Burnt Store Road as a controlled access road and dictates the access points and the intersection configurations, no intersection analyses were included in this study, as agreed by the Department. No Intersection Control Evaluation (ICE) was conducted in this study, as recommended by the District Traffic Operations Group. Therefore, the link level analyses for the Build Alternative were only included, as agreed by the District Systems Planning Office.

As stated in **Section 4.3**, all future AADT volumes were linearly projected using a recommended growth rate of 8.2% for the Build Alternative, then rounded using the AASHTO rounding convention. The AADT volumes, the recommended K and D factors were used to calculate the daily design hour volumes (DDHVs) for each segment as shown in **Table 4-4** and **Table 4-5** for the opening year and the design year, respectively. The LOS measure for the segments under the Build Alternative (four-lanes divided) was developed by comparing the calculated DDHVs with the threshold volumes from the Link Service Volumes on Arterials developed by Lee County as agreed by the Department.

**Table 4-4: Build Opening Year (2025) Segment Analysis**

Burnt Store Road Segment	AADT Volume	K*D (0.095 x 0.58)	DDHV	V/C	LOS
Van Buren Parkway to Kismet Parkway	18,500	0.0551	1,019	0.35	B
Kismet Parkway to Delilah Road	14,000	0.0551	771	0.26	A
Delilah Road to NW 26 <sup>th</sup> Terrace	13,500	0.0551	744	0.25	A
NW 26 <sup>th</sup> Terrace to Janis Road	13,500	0.0551	744	0.25	A
Janis Road to Sand Road	13,500	0.0551	744	0.25	A
Sand Road to Caloosa Parkway	13,500	0.0551	744	0.25	A
Caloosa Parkway to Sanctuary Estate Drive	13,000	0.0551	716	0.24	A
Sanctuary Estate Drive to James Walter Drive	13,000	0.0551	716	0.24	A
James Walter Drive to NW 40 <sup>th</sup> Lane	13,000	0.0551	716	0.24	A
NW 40 <sup>th</sup> Lane to Durden Parkway	13,000	0.0551	716	0.24	A
Durden Parkway to Charlee Road	13,000	0.0551	716	0.24	A
Charlee Road to Islamorada Boulevard	14,000	0.0551	771	0.26	A
Islamorada Boulevard to Vincent Avenue	14,500	0.0551	799	0.27	A

**Table 4-5: Build Design Year (2045) Segment Analysis**

Burnt Store Road Segment	AADT Volume	K*D (0.095 x 0.58)	DDHV	V/C	LOS
Van Buren Parkway to Kismet Parkway	41,500	0.0551	2,287	0.78	D
Kismet Parkway to Delilah Road	31,000	0.0551	1,708	0.58	C
Delilah Road to NW 26 <sup>th</sup> Terrace	29,500	0.0551	1,625	0.55	C
NW 26 <sup>th</sup> Terrace to Janis Road	29,500	0.0551	1,625	0.55	C
Janis Road to Sand Road	29,500	0.0551	1,625	0.55	C
Sand Road to Caloosa Parkway	29,500	0.0551	1,625	0.55	C
Caloosa Parkway to Sanctuary Estate Drive	29,500	0.0551	1,625	0.55	C
Sanctuary Estate Drive to James Walter Drive	29,000	0.0551	1,598	0.54	C
James Walter Drive to NW 40 <sup>th</sup> Lane	29,000	0.0551	1,598	0.54	C
NW 40 <sup>th</sup> Lane to Durden Parkway	29,000	0.0551	1,598	0.54	C
Durden Parkway to Charlee Road	29,000	0.0551	1,598	0.54	C
Charlee Road to Islamorada Boulevard	31,000	0.0551	1,708	0.58	C
Islamorada Boulevard to Vincent Avenue	32,500	0.0551	1,791	0.61	C

The Build Alternative for both opening year (2025) and design year (2045) is expected to operate at an acceptable LOS or better, and a V/C ratio less than 0.85 which indicates that adequate roadway capacity is available, and vehicles are not expected to experience significant queues and delays.

The proposed widening from two-lane undivided roadway to four-lane divided roadway is desirable from a safety perspective, as reducing delay and the frequency of stopping on a major road is expected to help reduce crashes. In line with the 2019 FDOT Safety Analysis Guidebook for PD&E Studies, a Crash Modification Factor (CMF) analysis method was used to compare relative safety benefits of the proposed widening with a restrictive median concept. A CMF is only an estimated value of the crash reduction potential of a treatment or alternative. CMFs with a value less than 1.0 indicate an expected decrease in crashes. CMFs are rated with a star quality rating that indicates the quality or confidence in the results of the studies producing the CMFs. Star ratings are assigned on a scale of one star to five stars, with five stars indicating the highest and most reliable rating.

The following CMFs from the FHWA’s Clearinghouse were found as the CMFs relevant to this project with a 4-star rating (**Table 4-6**):

**Table 4-6: Crash Modification Factors**

CMF ID	Measure	Area Type	CMF	Crash reduction
7734	Add a through lane on both directions and a raised median	Rural	0.71	29.0%
7569	Convert two-lane roadway to four-lane divided roadway	Rural	0.712	28.8%
7566	Convert two-lane roadway to four-lane divided roadway	Urban	0.341	65.9%
7732	Add a through lane on both directions and a raised median	Urban	0.32	68.0%

Based on the CMFs, it is anticipated that the proposed widening with a restrictive median concept may result in a potential reduction in crashes.

#### 4.8 Comparative Alternatives Evaluation

The focus of the build analysis is to identify alternatives which enhance roadway capacity, address existing safety and operational concerns, and provide multi-modal accommodations within the project corridor. Corridor design challenges and constraints include:

- 1) A high water table and roadway flooding during seasonal events that require the roadway vertical alignment to be elevated up to 3 feet;
- 2) Notable offsite flows from the east that require capture in large ditches or pipes and conveyance under the roadway;
- 3) Presence of state and county-owned and managed conservation lands on both sides of the roadway; and
- 4) A utility parcel and fiber optic building hub at the northern project limits where roadway widening and tie-in to the existing 4-lane divided roadway would occur.

##### 4.8.1 Roadway Alternatives Analysis Summary

Through early coordination with Lee County, it was discussed that for consistency with adjacent improved sections of Burnt Store Road, a roadway typical section that allows for expansion to a future six-lane facility was appropriate for the project corridor. Original alternatives consisted of four-lane rural typical sections expandable to six-lane suburban typical sections. Due to the sporadic and significant seasonal

flows through the area, it was determined that drainage design was the primary constraint in the ability to reduce ROW needs for these typical section options. All options included open ditches, ranging from two to four total. Options that included combined ditches, where off-site water and roadway stormwater on the same side of the road would be directed into a single, combined ditch, are referred to as co-mingled water. Each option included 11-foot travel lanes, ten-foot outside shoulders with 7 feet paved, four-foot inside paved shoulders, a 52-foot median that would be reduced to 30-feet when ultimately widened to 6-lanes, ten-foot shoulders with seven-feet paved, and a 10-foot shared-use path on the west side and 12-foot shared use path on the east side..

Four options were evaluated that differed in terms of drainage design and specifically whether off-site flows and roadway stormwater was combined, or co-mingled. Given drainage conditions in the project area, the need to raise the roadway elevation by up to three feet, and the need to accommodate significant flows from east to west, ROW impacts were unavoidable. Rural Option 1 would require 272 feet of right-of-way (ROW) to allow for up to two ditches on each side of the roadway to separate roadway drainage from offsite flows, Rural Option 2 would require 254 feet of ROW to allow for up to two ditches on the east side to separate flows while comingling water on the west side, Rural Option 3 would require 235 feet of ROW and would comingle water on both sides, and Rural Option 4 would similarly require 235 feet of ROW and involve comingling but also would include an inverted crown with median ditch.

In order to estimate ROW impacts associated with each typical section option, roadway alignments were preliminarily modeled. These typical sections initially evaluated included (1) separate roadside ditches for stormwater runoff plus offsite/bypass ditches on the east and west sides where needed, for a total of up to four ditches total and 272-feet of ROW; (2) two separate ditches on the west side of the road to isolate offsite flows initially, which drained to one combined ditch on the east side of the road for a total of up to three ditches total and 254 feet of ROW; (3) combined ditches on both sides of the road for a fully co-mingled system resulting in two ditches total and 235 feet of ROW; and (4) combined ditches on both sides of the roadway with a median ditch for road drainage, requiring an inverted crown where the travel lanes slope towards the median, and 235 feet of ROW.

Of these options initially considered, Typical Section Rural Option 3 was selected for detailed evaluation (**Figure 4-1**). Two horizontal alignment alternatives were fully modeled and evaluated for impacts to residences, businesses, conservation and recreational lands, and environmental resources. Mainline parcel impacts ranged from 72 to 106 parcels. The main difference with the two alignment alternatives was at the location of the Burnt Store Marina development, located west of Burnt Store Road, and state conservation land (Fred C. Babcock/Cecil M. Webb Wildlife Management Area- Yucca Pens Unit) located east of Burnt Store Road. Each alignment alternative resulted in impacts to either the west side (residential development) or to the east side (state conservation lands). Following coordination with Lee County, rural alternatives were discarded from further consideration given the ROW impacts.

The project team then developed one suburban and two urban typical section options. These options were preliminarily modeled and found to reduce the typical section width to either 213-feet for the suburban option and Urban Option 1, and to 200-foot for the Urban Option 2. The Suburban Option included 11-foot travel lanes, a 30-foot median, seven-foot shoulders/bike lanes, a 10-foot shared-use path on one side and 12-foot shared use path on the other side of the road, and an open drainage system



**Figure 4-1: Rural Typical Section Selected for Detailed Evaluation**

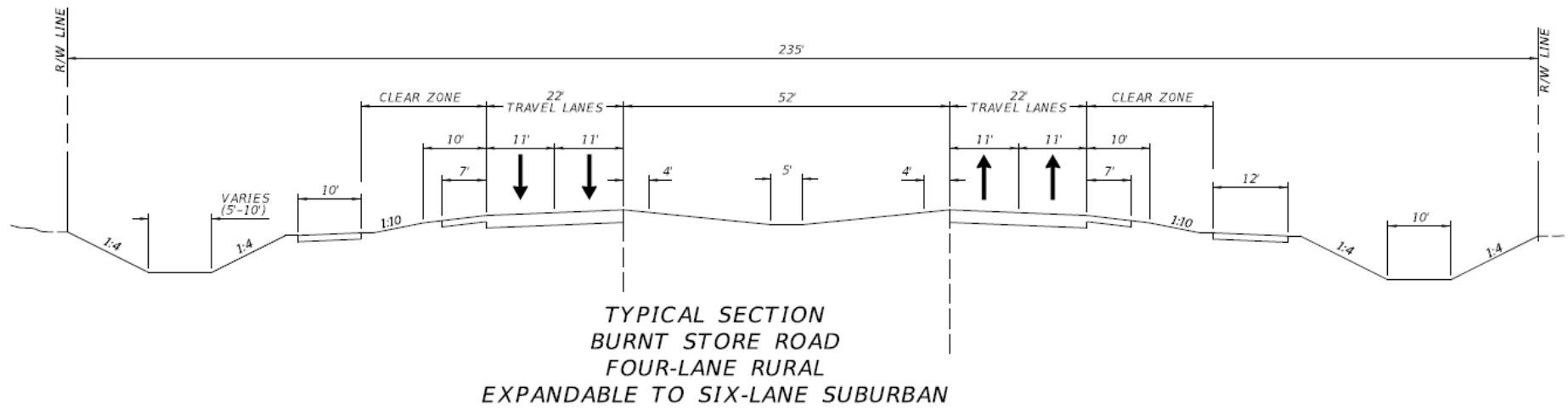

with comingling of water on each side. The 30-foot median would be reduced to 22-feet when ultimately widened to 6-lanes but this would require shifting of the lanes, reconstruction of the shoulders and the shared use paths. Urban Option 1, requiring approximately 220 feet of ROW, included 11-foot travel lanes, a 40-foot median that would be reduced to 22-feet when ultimately widened to 6-lanes, seven-foot shoulders/bike lanes with outside curb on both sides, a 10-foot shared-use path on both sides of the road, a closed roadway drainage system, and an open ditch on approximately two-thirds of the project limits to capture offsite flows and convey water to the west side. Urban Option 2, generally requiring 200-feet of ROW but requiring some minor ROW impacts in certain areas of the corridor, was similar to Urban Option 1 but eliminated the shoulders/bike lanes, included 12-foot shared use paths on both sides of the road, and changed ditch slopes in an effort to fit within the existing ROW.

Similar to the rural typical section options, horizontal alignment alternatives were fully modeled. An optimized alignment was selected, meaning that widening was proposed on different sides of the roadway in different locations throughout the corridor to avoid sensitive resources and developed parcels. The suburban typical section option was discarded due to ROW impacts including impacts to state conservation lands, and Urban Option 2 was discarded since it lacked the shoulders and bike lanes. The Urban Option 1 alternative was ultimately named Build Alternative 1 and was carried forward for analysis. Urban Option 1 avoided most ROW impacts including those to the Burnt Store Marina, state lands, and only had minimal impacts to a utility parcel.

In additional effort to reduce ROW impacts, a second urban typical section alternative was later developed that included the design of a pipe instead of an open ditch to capture offsite flows. Horizontal alignments were similarly modeled and the optimized alignment was found to be the only alternative analyzed that completely eliminates ROW impacts along the mainline. It fits within the existing 200-feet of ROW, with the one exception of the utility property. However, like the other alternatives, utility parcel impacts were minimal.

Since reduction of ROW impacts was a prime focus, a third urban typical section alternative, Urban Option 3, was later developed that closely approximated Build Alternative 1 but included the design of a pipe instead of an open ditch to capture offsite flows. Horizontal alignments were similarly modeled, and the optimized alignment was found to be the only alternative analyzed that fits within the existing 200-feet of ROW, with the one exception of the utility property. However, like the other alternatives, utility parcel impacts were minimal. Urban Option 3 was renamed to Build Alternative 2 and was carried forward. Following detailed analysis, Alternatives 1 and 2 were presented to the public in the Alternatives Public Meeting, held in-person on August 30, 2022 and virtually on September 1, 2022. **Figure 4-2** and **Figure 4-3** show the typical sections developed for Build Alternative 1 and Build Alternative 2, respectively.

**Figure 4-2: Build Alternative 1  
Urban Typical Section with Ditch for Off-Site Flows**

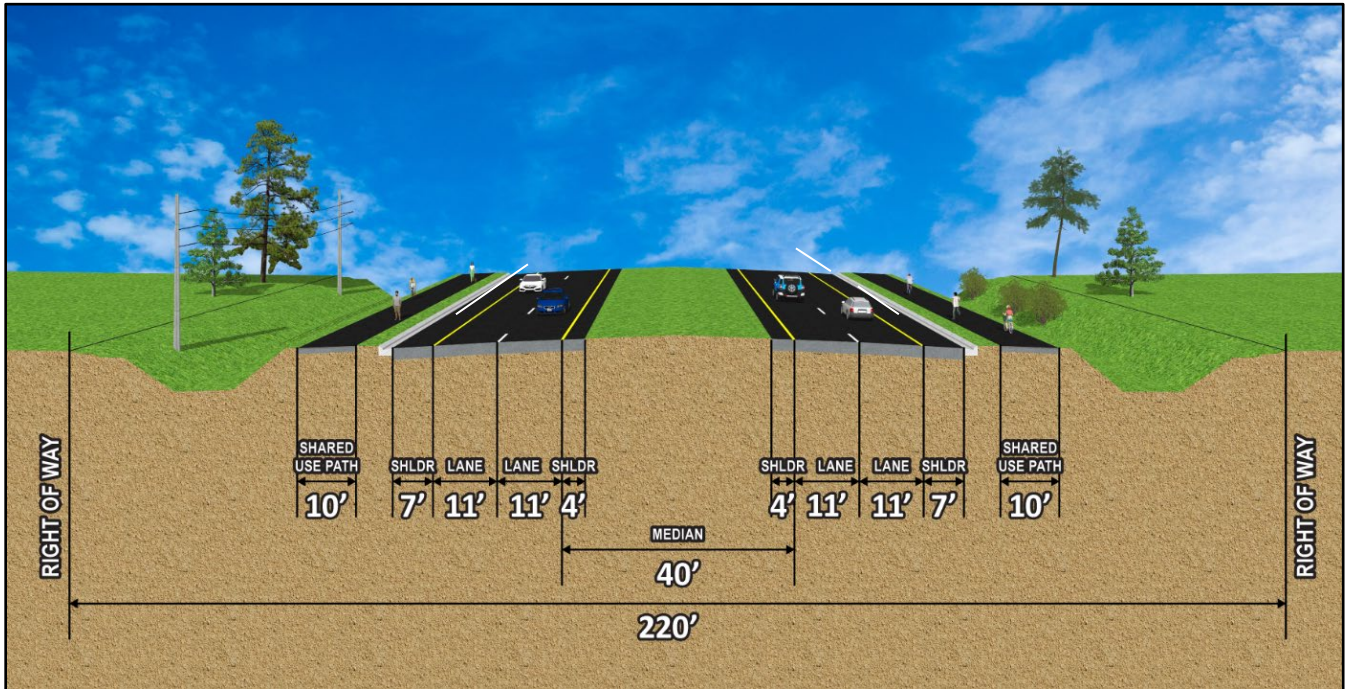

**Figure 4-3: Build Alternative 2  
Urban Typical Section with Pipe for Off-Site Flows**

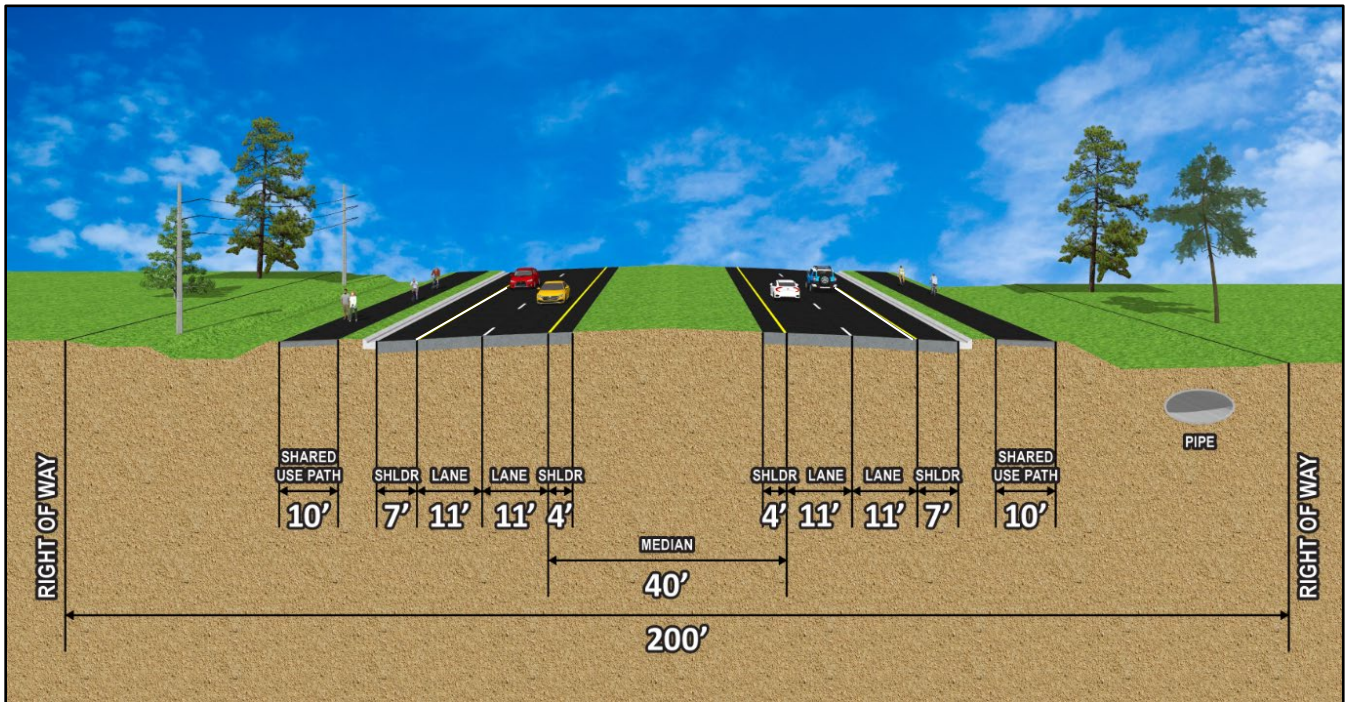



## 4.8.2 Roadway Evaluation Matrix

Each build alternative was evaluated based on environmental effects, right-of-way needs, and project costs. **Table 4-7** displays the matrix shown at the Alternatives Public Meeting in 2022, for the results of the alternatives evaluation process. Considerations such as impacts to environmental resources, and the acres of ROW needed for roadway improvements and stormwater facilities, were quantified. The matrix also details cost estimates for wetland mitigation, ROW acquisition, construction, design, and construction engineering and inspection (CEI). Construction costs were based on July 2022 unit costs and were estimated using the FDOT Long Range Estimate (LRE). Alternative 1 has more parcel impacts, greater acreage for new ROW need, and higher potential for effects on listed species as compared to Alternative 1. Alternative 2 also would result in minor impacts to three conservation properties as compared to no impacts associated with Alternative 2. Costs are similar between the two alternatives, but Alternative 1 has a lower overall project cost. Note that unit costs have increased dramatically in recent years and these estimates are now notable higher based on current dollars.

## 4.8.3 Selection of the Roadway Preferred Alternative

Based on the consideration of the impacts shown in the evaluation matrix, the input received at the Alternatives Public Meeting, and through stakeholder coordination, Alternative 2 (Urban Typical Section with Pipe for Offsite Flows) was selected as the Preferred Alternative. Details of the Preferred Alternative are further discussed in **Section 6.0**.

**Table 4-7: Evaluation Matrix**

Evaluation Factors	Alternative 1 Urban Typical Section with Ditch for Offsite Flows	Alternative 2 Urban Typical Section with Pipe for Offsite Flows	No-Build Alternative
<b>Benefits</b>			
Reduced traffic congestion			
Bicycle accommodations			
Pedestrian accommodations			
Increased pedestrian/bicycle safety			
Enhanced safety for all users including hurricane evacuation			
<b>Right-of-Way (ROW) Impacts</b>			
ROW to be acquired for roadway (acres)	8.7	0.2	0
ROW to be acquired for stormwater management (acres)	35.8	35.8	0
Number of business parcels impacted	0	0	0
Number of utility parcels impacted	1	1	0
Number of residential parcels impacted	0	0	0
Number of community resource parcels impacted	0	0	0
Number of unimproved properties impacted	24	0	0
Number of potential business relocations	0	0	0
Number of potential residential relocations	0	0	0
<b>Environmental Effects</b>			
Number of archaeological/historic sites impacted	0 / 0	0 / 0	0 / 0
County conservation and recreation land impacts (parcels / acres)	2 / 0.9	0 / 0	0 / 0
State conservation and recreation land impacts (parcels / acres)	1 / 0.6	0 / 0	0 / 0
Wetlands and surface water impacts (acres)	29.0	27.1	0.0
Threatened and endangered species (potential)	Moderate	Low	None
Number of noise sensitive sites	20	20	0
Number of contamination sites with medium or high contamination risk	2 / 0	2 / 0	0 / 0
Farmland impacts (acres)	3.9	0.0	0.0
Floodplain impacts (acres)	33.9	31.2	0.0
<b>Estimated Project Costs (subject to change)</b>			
Final design	\$6,696,000	\$7,483,000	\$0
Reimbursable utility relocation	\$720,000	\$720,000	\$0
Right-of-way for roadway (to be purchased)	\$7,535,000	\$135,000	\$0
Right-of-way for stormwater management (to be purchased)	\$24,500,000	\$24,500,000	\$0
Wetland mitigation	\$2,657,000	\$2,508,000	\$0
State land mitigation (Acquisition Restoration Council process)	<b>\$1,120,000</b>	\$0	\$0
Roadway construction	\$66,960,000	\$74,825,000	\$0
Construction engineering and inspection	\$6,696,000	\$7,483,000	\$0
<b>Preliminary Estimate of Total Project Cost</b>	<b>\$116,884,000</b>	<b>\$117,654,000</b>	<b>\$0</b>

Note: Matrix as presented in the Public Alternatives Meeting; cost estimates reflect July 2022 unit costs

#### 4.8.4 Comparative Bridge Alternatives Evaluation

The following describes the alternatives considered for the southbound bridge over Gator Slough Canal and the bridge culvert over Yucca Pen Creek. These alternatives are viable with either mainline roadway widening alternative selected.

##### **Bridge No. 120025 (Southbound Burnt Store Road over Gator Slough Canal)**

There are two options for this bridge location. Both options were evaluated as part of the *Bridge Hydraulics Report* (January 2023), provided under separate cover. This document includes the results of a sea level rise analysis, storm surge analysis, hydraulic model, and scour calculations. The 50-year stage for storm surge with sea level rise serves as the design high water; the 100-year and 500-year results were used for scour calculation per the FDOT Drainage Manual.

Option 1 involves the replacement of the existing bridge with a concrete bridge using FIB 36" prestressed girders with 8½" reinforced concrete slab. The bridge would have a span arrangement matching the existing northbound bridge, consisting of three spans 76'-1" in length for a total length of 228'-3". The span configuration would maximize the hydraulic opening of Gator Slough Canal. The deck would carry two 11'-0" lanes with 17'-0" inside and 10'-0" outside shoulders. The 14'-0" shared use path would be separated from the travel lanes by a 36" single slope traffic railing, per the FDOT Standard Plans for Bridge Construction Index 521-427. The traffic railing would have pedestrian/bicycle bullet railing, per Index 515-021. Along the median side of the deck, the same type of 36" railing would be used. Pedestrians and bicyclists would be protected along the outside of the path with bridge pedestrian/bicyclist railing (aluminum), per Index 515-061. The total width of this bridge option is 66'-5½". The substructure would be comprised of reinforced concrete caps (4'-0" x 3'-0") with six 24" prestressed concrete piles each. End bents and the intermediate bents piles would be plumb.

For the four-lane design, the bridge would have two, 11-foot travel lanes with a 17-foot inside shoulder and 10-foot outside shoulder. When Burnt Store Road is widened to six lanes, the bridge can be re-striped to include three, 11-foot lanes, a six-foot inside shoulder and a ten-foot outside shoulder. **Figures 4-4** and **Figure 4-5** depict Option 1 for the four-lane and six-lane configurations, respectively.

The proposed low member elevation of the new bridge was initially proposed to be the same as the existing northbound bridge, +9.20 ft-NAVD88. However, based on the bridge hydraulic analysis, this would provide 1.96 feet of drift clearance above the design high water (+7.24 ft-NAVD88), which is just under the FDOT 2-foot drift clearance requirement. Therefore, the low member elevation for the southbound bridge is recommended to be +9.24 ft-NAVD88. Option 1 has a low debris potential because its substructures would be constructed in line with the existing northbound bridge.

Option 2 involves construction of a new single span shared use path bridge and preservation of the existing vehicular bridge. The new pedestrian bridge would be prefabricated steel with a span length of approximately 215 feet. The length of the bridge is dictated by the clear opening and the tie backs of the existing sea walls. The clear width of the bridge would be 14'-0", 10'-0" plus a 2'-0" border on either side. The abutments would be comprised of reinforced concrete caps and prestressed concrete piles.

**Figure 4-4: Bridge No. 120025 Option 1 Typical Section (four-lane configuration)**

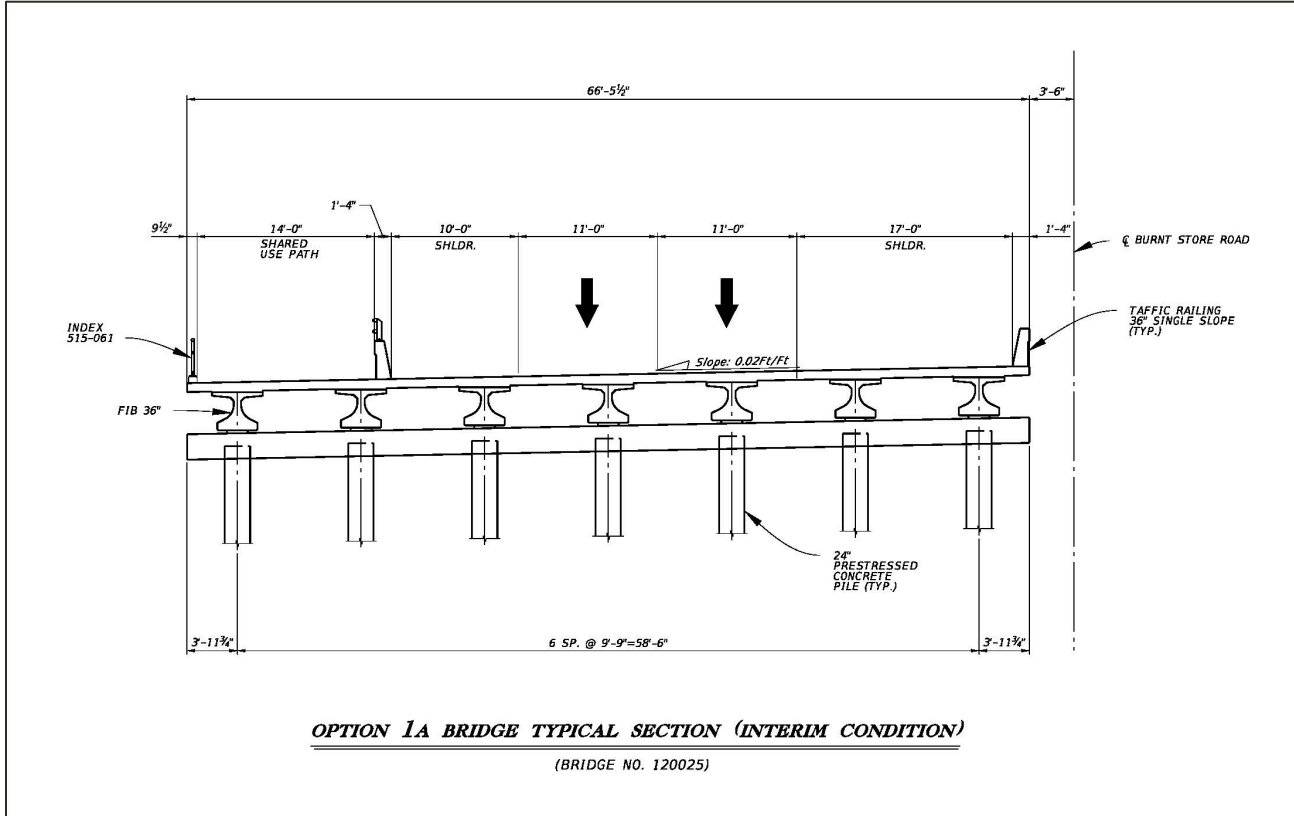

**Figure 4-5: Bridge No. 120025 Option 1 Typical Section (six-lane configuration)**

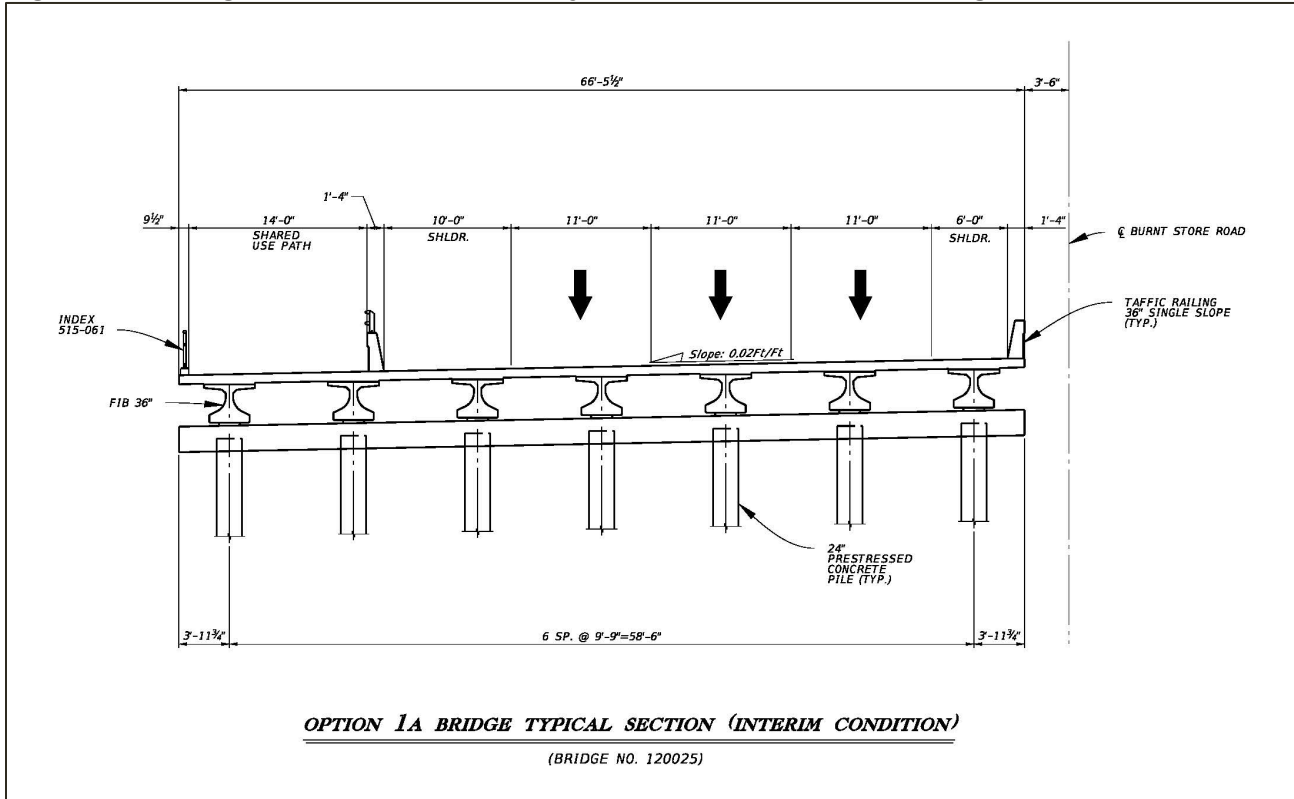

The concrete railings on the existing bridge would be retrofitted to use 36" single slope traffic railing, per Index 521-427, with the addition of dowels for the connection to the exterior prestress slab units. The re-striping of the deck would be necessary to provide two 11-foot travel lanes, a six-foot inside shoulder and an 11'-7" outside shoulder. **Figure 4-6** depicts Option 2.

The proposed low member elevation of the new pedestrian bridge was initially proposed to be the same as the existing southbound bridge, +7.12 ft-NAVD88. However, based on the bridge hydraulic analysis, this elevation is lower than the design high water and does not satisfy FDOT's 2-foot drift clearance requirement for vertical clearance. Therefore, while the low member elevation of the new pedestrian bridge will be raised to meet criteria (+9.24 ft-NAVD88), the existing southbound bridge would remain more than two feet lower than criteria. Option 2 has a higher debris potential as compared to Option 1 because the substructures of the existing southbound bridge are currently not in line with the existing northbound bridge.

**Figure 4-6: Bridge No. 120025 Option 2 Typical Section**

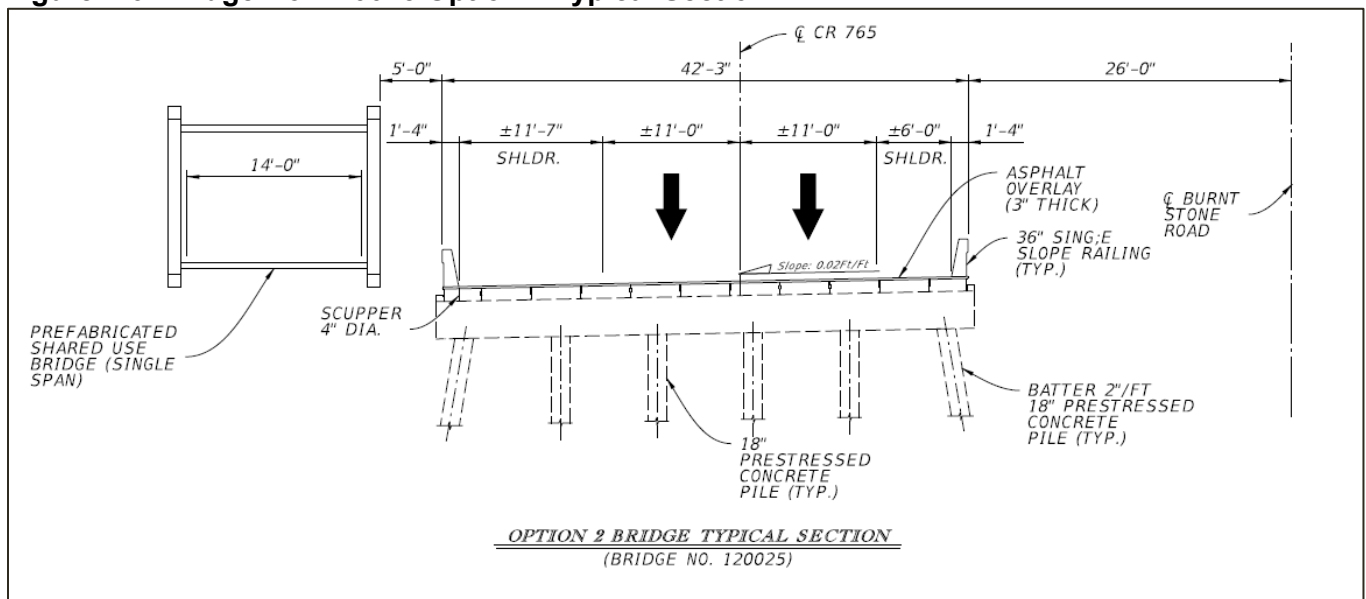

Option 1 was selected as the Preferred Alternative for Bridge No. 120025 given consideration of sea level rise, storm surge, drift clearance, and consistency with the proposed roadway profile change.

**Bridge No. 124140 (Northbound Burnt Store Road over Gator Slough Canal)**

The existing bridge will remain. No further improvements are proposed. The low member elevation of this bridge is +9.20 ft-NAVD88 as measured from the as-built plans.

**Bridge No. 120054 (Burnt Store Road over Yucca Pens Creek)**

The existing culvert requires replacement due to its condition and age. There are two replacement options. Option 1 involves replacement in-kind. This option will require dewatering of the creek, one cell at a time or temporary creek diversion. Option 2 involves replacement with a single span reinforced concrete flat slab bridge. The deck slab would be approximately 15 inches thick. The end bents would be comprised of 24-inch piling with 10-inch concrete sheet piling and reinforced concrete caps. Option 2



does not require dewatering for the construction of the bridge. **Figures 4-7 and Figure 4-8** depict Options 1 and 2, respectively.

**Figure 4-7: Bridge No. 120054 Option 1 Typical Section**

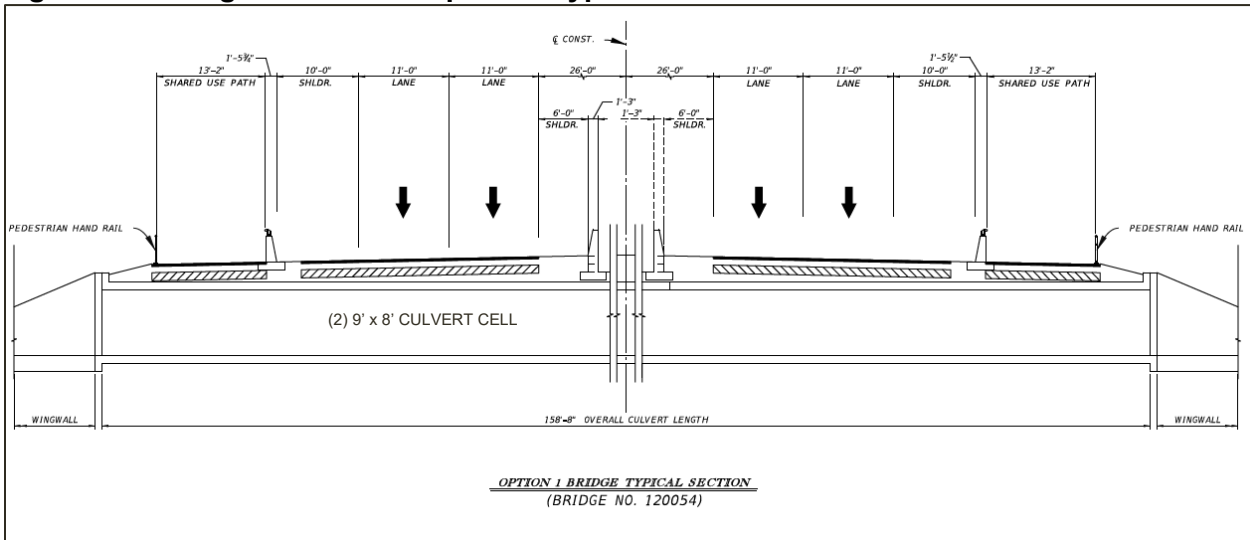

**Figure 4-8: Bridge No. 120054 Option 2 Typical Section**

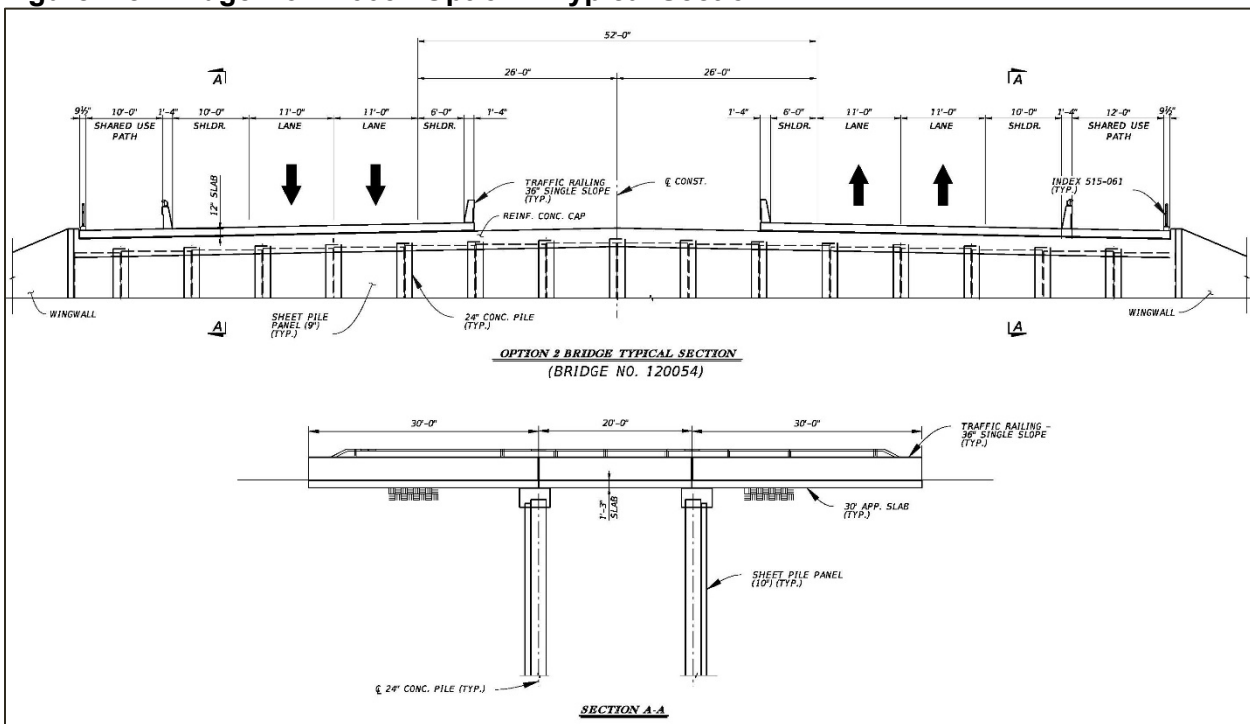

Option 1 was selected as the Preferred Alternative for Bridge No. 120054 since a bridge culvert is adequate for this location and a new bridge would result in unnecessary additional project cost.

## 5.0 PROJECT COORDINATION AND PUBLIC INVOLVEMENT

A *Public Involvement Plan* (June 2020) was prepared under separate cover. This plan details the public involvement approach for the project and documents public outreach methods including a project website, newsletters, a public meeting, and a public hearing. Agencies and elected and appointed officials were included in a mailing list as well as other project stakeholders. The *Comments and Coordination Report (Date TBD)*, prepared under separate cover, fully documents the public and stakeholder involvement conducted for this project.

### 5.1 Agency Coordination

Throughout the project, coordination has been ongoing with local government entities including Lee County, Lee County MPO, Charlotte County, Charlotte County MPO, and the City of Cape Coral at key milestones in the study. Meetings are summarized in **Table 5-1**.

**Table 5-1: Summary of Local Agency Meetings**

Date	Meeting	Attendees	Topics Discussed
3/31/2020	Agency Project Kickoff Meeting	FDOT, Lee County (DOT, Public Works, Parks and Recreation, Community Development)	Data gathering, typical sections, Access Management Resolution, planned development
5/8/2020	Design Criteria and Access Management Meeting	FDOT, Lee County (DOT, Public Works)	Design criteria, access management, typical sections
8/27/2020	South Florida Water Management District (SFWMD) Pre-Application Meeting	FDOT, SFWMD	Preliminary drainage overview/discussion, wetland impacts, compensatory treatment concepts, wetland mitigation
9/25/2020	PD&E Coordination Meeting	FDOT, Lee MPO, Charlotte County-Punta Gorda MPO, Charlotte County	PD&E project limits, future funding phases, logical termini, planning consistency
11/20/2020	Design Criteria and Access Management Meeting	FDOT, Lee County (DOT, Public Works)	Typical sections, drainage needs, ROW needs
1/27/2021	SFWMD Follow-up Pre-Application Meeting	FDOT, SFWMD, Lee County DOT	Drainage comingling, treatment and attenuation, alternative drainage concepts
2/11/2021	Project Design Meeting	FDOT, Lee County DOT	Drainage comingling, stormwater ponds, bridge over Gator Slough Canal, Access Management Resolution
6/28/2021	Project Design Meeting	FDOT, Lee County DOT	Typical section and alignment alternatives, pond siting alternatives, viability of potential developments for stormwater
9/1/2021	Project Design Meeting	FDOT, Lee County DOT	roadway and drainage analysis, typical section decision, conceptual pond sites
3/7/2022	Lee County Coordination Meeting	FDOT, Lee County DOT	Alignment alternatives and typical sections, draft alternatives matrix, conceptual pond siting

Date	Meeting	Attendees	Topics Discussed
5/2/2022	Lee County and City of Cape Coral Coordination Meeting	FDOT, Lee County DOT, City of Cape Coral	Stormwater pond alternatives on City of Cape Coral property
11/3/2022	Lee County MPO TAC and CAC Meeting presentations	TAC and CAC members, members of the public	Update on PD&E Study and alternatives workshop
11/10/2022	Post-Public Meeting Discussion	FDOT, Lee County DOT	Public comments received, access management, turn lanes, truck bulb-outs, wildlife feature viability
11/22/2022	Lee County BPCC Meeting presentation	BPCC members, members of the public	Update on PD&E Study and alternatives workshop
11/18/2022	Lee County MPO Board Meeting presentation	MPO Board members, members of the public	Update on PD&E Study and alternatives workshop
12/15/2022	Charlotte County-Punta Gorda MPO Board Meeting presentation	MPO Board members, members of the public	Update on PD&E Study and alternatives workshop
2/28/2023	Second Post-Public Meeting Discussion	FDOT, Lee County DOT	Public comments received, access management, project commitments
9/21/2023	Project update meeting	FDOT, Lee County DOT	Vincent Avenue intersection discussion, Lee County access management resolution, design phase plans
3/29/2024	Vincent Avenue coordination meeting	FDOT, Lee County DOT	Viable options for Vincent Avenue intersection design, design phase
4/16/2024	Vincent Avenue coordination meeting	FDOT, Lee County DOT, Charlotte Co	Presentation of recommended alternative for Vincent Avenue intersection
10/3/2024	Charlotte County TAC, CAC, BPAC Meeting presentations	TAC, CAC, BPCC members, members of the public	Presentation of the Continuous Green T intersection for Vincent Avenue
11/21/2024	Charlotte County-Punta Gorda MPO Board Meeting presentation	MPO Board members, members of the public	Presentation of the Continuous Green T intersection for Vincent Avenue

TAC = Technical Advisory Committee; CAC = Citizen Advisory Committee; BPAC = Bicycle Pedestrian Coordinating Committee

## 5.2 Alternatives Public Meeting

An in-person Alternatives Public Workshop was held on August 30, 2022, at Northwest Regional Library from 5:00 PM to 7:00 PM. The meeting followed an open house format and provided an opportunity for the public to review the proposed project layout and speak one-on-one with project team members. A virtual Alternatives Public Workshop was held on September 1, 2022 starting at 6:00 PM which included a meeting introduction, project video, and a question and answer period. Attendees typed-in questions, the virtual meeting moderator read the questions, and the project team provided answers while using concept plan maps for display purposes.

The in-person meeting was attended by 39 citizens. Local citizen groups represented at the meeting included the Northwest Cape Coral Neighborhood Association and Burnt Store Corridor Coalition. All attendees were given the opportunity to provide written comments at the meeting or within the 10-day (extended to 12 days due to the Labor Day holiday) comment period following the meeting. The virtual meeting was attended by 40 citizens.

The comment period ended September 12, 2022. A total of 186 comments were submitted during the commenting period. The majority of the comments were related to requesting a northbound left turn option from the Burnt Store Marina property. There are two roads that provide access to this community. Vincent Road, which is also the Lee/Charlotte County Line, provides access to two gates into the community for both commercial and private vehicles. Vincent Road is used by trucks and trailers accessing the marina and other businesses within the property and is also the designated access point for construction-related vehicles. Private vehicles also use these entrance gates. Islamorada Boulevard, which is a more direct access point into the Burnt Store Marina property, leads into the single-family home portion of the community, with the other features of the marina property further to the west. While most comments did not specify which road this northbound left turn lane was desired, those that did specify most often cited Vincent Road as the more logical location. Other comments received were related to access management at other intersections and at future planned development parcels, southbound right turn lanes at Vincent Road, Islamorada Boulevard, and Durden Parkway, need for driveway access, acceleration lanes, noise concerns, flooding concerns, landscaping and lighting, bike lanes and shared-use paths, parking opportunities to access the future shared-use paths, stormwater ponds, and wildlife impacts and underpass. Public comments were discussed with Lee County DOT during the November 10, 2022 coordination meeting.

Presentations were made to the Lee County MPO Technical Advisory Committee (TAC) and Citizen Advisory Committee (CAC) on November 3, 2022; the Bicycle Pedestrian Coordinating Committee (BPCC) on November 22, 2022, the Lee County MPO Board on November 18, 2022, and the Charlotte County-Punta Gorda MPO Board on December 15, 2022. These presentations provided a project overview, build alternatives, review of the evaluation matrix, and summary of the public workshop and comments received. Several members of the public attended both Lee County MPO and Charlotte-Punta Gorda MPO Board meetings to request the consideration of a northbound left turning movement option at the Burnt Store Marina. Lee County DOT was in attendance at the Lee County MPO Board meeting and stated that the agency would consider other intersection designs at Vincent Road during the final design phase of the project.

Following these presentations, however, more public comments were submitted to the local agencies, FDOT, and state officials requesting an intersection design at Vincent Avenue that allows for a northbound left turn movement. The project team and Lee County discussed a change in approach to examine this intersection during the PD&E Study. It was decided to collect updated traffic data at this intersection (spring 2024), conduct a detailed engineering analysis to identify viable intersection options and vet them for potential environmental impacts, and subsequently identify a preferred intersection design to present to the public. **Section 6.0** details the additional traffic and intersection analysis that was completed. The preferred intersection alternative, referred to as the Continuous Green 'T' (CGT) intersection, was discussed with Charlotte County, then subsequently presented to the Charlotte County-Punta Gorda MPO Board, TAC, CAC, and BPAC in October and November 2024. The presentation included a video that depicted how the intersection would operate and was also placed on the project website. Members of the public, including representatives from the Burnt Store Corridor Coalition, were in attendance at the Charlotte MPO meetings. Feedback received during these meetings was that the CGT is an acceptable intersection design for the Vincent Avenue intersection for the local community, Lee County DOT, and Charlotte County Public Works.

### **5.3 Public Hearing**

*To be completed after the public hearing.*

## 6.0 DESIGN DETAILS OF THE PREFERRED ALTERNATIVE

### 6.1 Typical Section

The Preferred Alternative has an urban typical section with curb and gutter and a closed roadway drainage system for the 4-lane construction. It provides future expandability to 6-lanes by allowing for widening to the median. The 200-foot typical section includes two 11-foot travel lanes in each direction, a 40-foot median, 7-foot paved outside shoulders, 4-foot paved inside shoulders, and 10-foot shared use paths on each side of the roadway. Design and posted speeds of 50 MPH are proposed. **Figure 6-1** depicts the preferred typical section.

Of the eight alternatives initially considered, including the two alternatives that were deemed viable and brought forward for public review at the Public Alternatives Meeting, this is the only alternative that generally eliminates ROW impacts along the mainline, fitting within the existing 200-feet of ROW. This is accomplished through the design of a pipe instead of an open ditch to capture offsite flows that are conveyed under the roadway. Stormwater runoff will be collected and conveyed to stormwater management facilities that will be constructed along the corridor. Impacts to floodplains will be mitigated with the construction of floodplain compensation sites. The approved typical section package is provided in **Appendix A**.

**Figure 6-1: Preferred Alternative Typical Section**

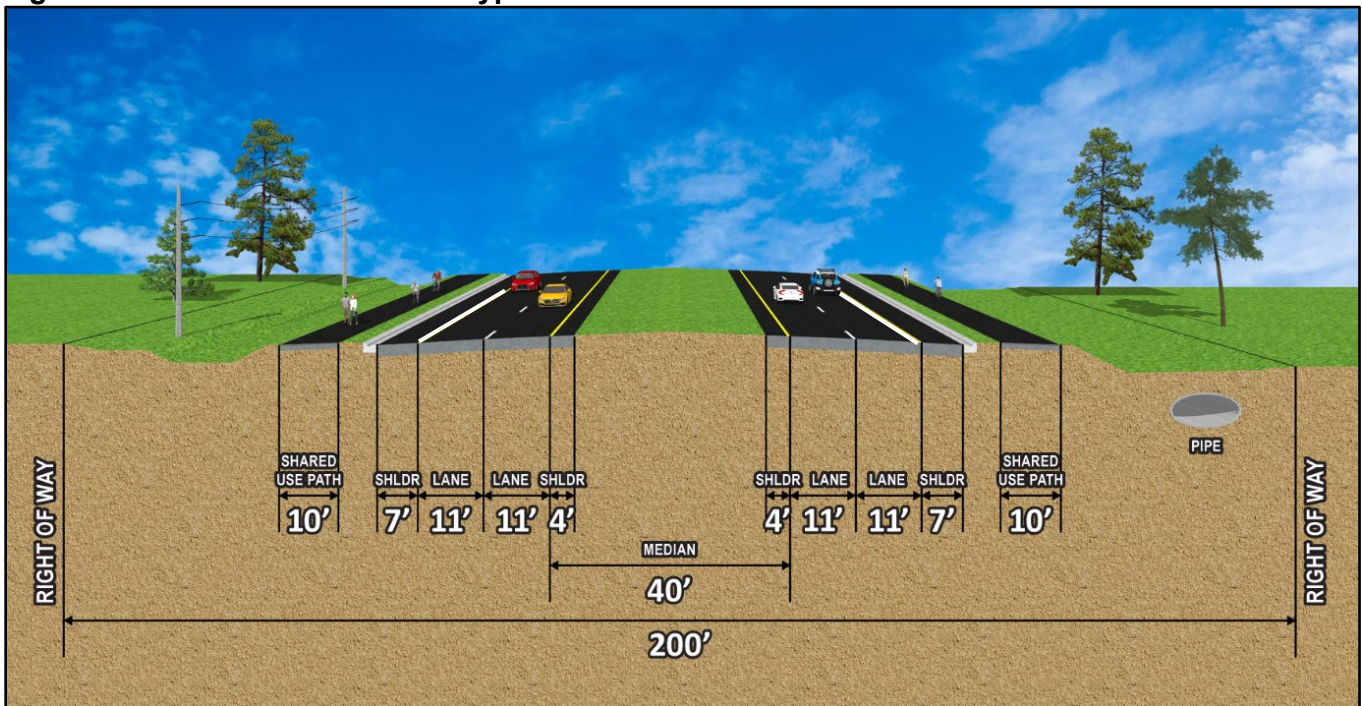

### 6.2 Design Variations and Design Exceptions

The design criteria used for this project is provided in **Table 3-1**. The Preferred Alternative requires a variation for lane width based on the design speed of 50 mph. The proposed lane width of 11 feet will allow for other proposed improvements to be constructed within the existing ROW, such as the 10-foot

wide shared use paths on each side and the seven-foot roadway shoulders. Narrower travel lanes also promote lower operating speed which helps to reduce crash severity. The median width is proposed to be 40 feet in the four-lane condition which includes an eight-foot inside shoulder, of which 4-feet is paved. The median would be transitioned to a 22-foot raised median with an inside curb in the ultimate six-lane condition and the outside shoulder would be reduced from 7-ft to 5-ft. If the design speed were to be reduced in the ultimate six-lane configuration from 50 MPH to 45 MPH this would remove the need for design variations for median width and lane width at that time.

### 6.3 Intersection Layout and Access Management

The Preferred Alternative is a four-lane divided facility and follows the Access Management Resolution developed by Lee County in 2020 for the proposed access points within the project corridor, with few exceptions. The proposed intersection layout for the corridor is shown in **Figure 6-2** and also on the Preferred Alternative concept plans provided in **Appendix B**.

The proposed recommendations under the Build Alternative that differ from the Lee County Access management Resolution include:

- Converting the proposed directional median opening at Vincent Avenue to a CGT intersection, which will allow for northbound left turning movements for Vincent Avenue eastbound traffic. Details are provided below in **Section 6.3.1**.
- Converting the proposed directional median opening at NW 40th Lane to a full median opening given presence of the fire station (Cape Coral Fire Department #7) located immediately south of NW 40th Lane, and considering installation of an emergency-vehicle traffic control signal for fire trucks. A directional median opening to allow northbound emergency vehicles to turn west into the fire station parking area is also recommended.

In addition, U-turn movements were considered for the corridor. These include:

- A U-turn for southbound traffic to turn northbound, located approximately 3,900 feet south of Charlee Road. This would allow for a second opportunity for traffic from Islamorada Boulevard to travel northbound. This recommendation is based on public comments from the Alternatives Meeting that expressed concern that during times of high traffic volume, it may be difficult to use the Charlee Road directional median opening to make the U-turn. This U-turn option would also service eastbound traffic from Charlee Road to turn and travel northbound.
- For large vehicles (e.g. box trucks such as WB-62FL) that would require additional room for U-turns, one northbound and one southbound “bulb-out” for truck turning are recommended. Since these turning movements were modeled and determined to require a small amount of additional ROW, locations were selected along the corridor where ROW would already be anticipated to be acquired for stormwater management or where Lee County already owns adjacent ROW. The recommended southbound to northbound bulb-out is located just north of Sand Road and the northbound to southbound bulb-out is located near James Walter Lane.

#### 6.3.1 Vincent Avenue Intersection Analysis

In March 2024, FDOT conducted new traffic counts for the Burnt Store Road at Vincent Avenue intersection, which included both 48-hour approach volume counts and 12-hour turning movement counts. This data was used for an Intersection Control Evaluation (ICE); the technical memorandum is included in **Appendix G**. The previously approved growth rates from the PTAR were then used in

developing updated opening year (2025) and design year (2045) volumes for the Burnt Store Road at Vincent Avenue intersection. Based on the traffic count data, the Midday and the PM peak traffic volumes exceeded the AM peak traffic volumes, with the PM peak hour volumes being the highest volumes during the day. Therefore, the Midday and PM peak hour volumes were used for the ICE analyses. The counts data showed that there was only one pedestrian crossing in a period of eight hours.

A signal warrant analysis was conducted with the latest traffic volumes (March 2024) and crash data (2019-2023) for the existing conditions. The ICE analyses with Capacity Analysis at Junctions (CAP-X) and Safety Performance for Intersection Control Evaluation (SPICE) were performed to identify viable intersection control options that would meet volume to capacity and Safe System for Intersections (SSI) requirements.

The ICE analyses for the design year (2045) showed that a Signalized Restricted Crossing U-turn (RCUT) would perform the best, closely followed by the traffic signal and CGT options. Although a roundabout performed well based on SPICE's SSI scoring criteria, it was not included in the top three viable control options since the CAP-X results indicated that it could experience capacity problems with a V/C ratio of 1.03 for the northbound movements during the PM peak hour. Therefore, a SIDRA (Ver.9.1) analysis was conducted to further investigate the operation of the roundabout in the design year. The results from the SIDRA analysis for the roundabout did not indicate V/C ratios exceeding 1.0 for the northbound movements, however the southbound (north approach) movements showed V/C ratios exceeding 1.0 during the design year PM peak. It was also identified that a roundabout option would require additional mainline ROW at a county-managed conservation property; however, in future conditions when Burnt Store Road would be widened to 6-lanes, the roundabout would need to be replaced with a different intersection design (e.g. full signalized intersection) and the additional ROW would no longer be needed. Therefore, the roundabout option was eliminated from consideration.

The signalized RCUT option was not considered further as it would require the eastbound Vincent Avenue traffic desiring to travel northbound to first turn right to travel southbound, and then make a U-turn to then travel northbound. This option would also require additional ROW to accommodate the turning movement of large vehicles (e.g. WB-62FL and large trucks trailering boats). The option conflicts with the local community requests to be able to make a northbound left turning movement at Vincent Avenue. The RCUT was also not preferred by the local agencies.

Out of the remaining two viable options, a full traffic signal would subject all movements to a red phase, whereas a CGT would allow continuous flow for the northbound through traffic while providing signalized control for all remaining movements. To further investigate the operational benefits between these two options, traffic signal operational analyses were conducted using Synchro (Ver.11) for the design year PM peak conditions. The analysis results showed that the average intersection delay for a CGT (LOS B) in the design year (PM Peak) would be 36% less compared to the delays with a traffic signal (LOS C). The SPICE analysis results also indicated that the CGT would have 15% less fatalities and injuries over the total project life compared to a traffic signal.

Although the CGT can be constructed without requiring additional ROW, this option would require a median modification to restrict the existing northbound left turning movement at the Wallaby Lane intersection located approximately 1,000 feet north of Vincent Avenue. A CGT would also require the



Wallaby Lane traffic to make a southbound, right turn onto Burnt Store Road and then make a U-turn at the median opening approximately 2,300 feet south of Vincent Avenue. This would add approximately 1.6 miles of additional travel for traffic from Wallaby Lane to drive northbound on Burnt Store Road. However, the impact will be minimal considering the overall operational benefits this option would provide. There are 19 residential parcels that use Wallaby Lane for access, with six parcels currently developed. Additionally, this median modification would restrict traffic existing the Charlotte County water treatment plant on the east side of Burnt Store Road from making a southbound left turning movement. Traffic would be required to first turn northbound and then make a U-turn at Cabana Road, located approximately 1,800 feet north of Wallaby Lane.

Based on extensive coordination with Lee County DOT and Charlotte County Public Works, followed by presentations to the Charlotte County-Punta Gorda MPO, the CGT option has been recommended as the preferred alternative for the Vincent Avenue intersection. This option will provide safe and efficient control for all vehicular movements, at the same time providing uninterrupted flow for the northbound through traffic, which was of significant concern for Lee County DOT, in consideration of hurricane evacuation needs. Also, the CGT does not require any ROW impact. Lee County recommended, and Charlotte County agreed, that the conceptual design and initial design plans will not include a pedestrian crossing across Burnt Store Road given the demonstrated lack of need (2024 traffic count data which included pedestrian counts). However, Lee County will monitor pedestrian activity at this intersection as the area continues to develop and will install a pedestrian crossing when determined needed.

### **6.3.2 Continuous Green T Intersection Operation**

The CGT is a three-legged intersection that allows one direction of travel on the major street to operate under free-flow conditions. The opposite major street direction of travel and minor street approach are typically controlled by traffic signals. On Burnt Store Road, northbound traffic would proceed through the Vincent Avenue intersection without stopping. Northbound traffic on Burnt Store Road turning west onto Vincent Avenue would first stop at the traffic signal before completing the movement. Southbound Burnt Store Road traffic would either proceed straight as through-traffic or turn westbound onto Vincent Avenue, just like at a conventional signalized T-intersection. From Vincent Avenue, motorists would use the right turn lane to proceed southbound on Burnt Store Road. To turn left onto Burnt Store Road, motorists would use the channelized lane on Burnt Store Road to merge after passing through the traffic signal. Cyclists would either navigate the intersection using crosswalks and pedestrian paths or could follow the same paths as vehicles. Pedestrians would use marked crosswalks to safely cross Vincent Avenue.

Benefits of the CGT include improved efficiency and safety. The free-flow of northbound traffic on Burnt Store Road allows more green light time to the other movements, reducing delay. Left-turning vehicles from Vincent Avenue would use a channelized receiving lane on Burnt Store Road to merge. The channelization of the left turning vehicles from Vincent Avenue reduces the potential for angle crashes,

## **6.4 Right-of-Way Needs and Relocations**

The existing ROW within the Lee County portion of the project consists of 200 feet while the small segment within Charlotte County is approximately 140 feet. The Preferred Alternative is centered within the existing ROW. An additional 0.2 acres of ROW from a single parcel is needed to construct the mainline roadway tie-in to the Charlotte County four-lane typical section. Approximately 35.8 acres is also needed for the construction of stormwater management facilities and floodplain compensation areas. No

residential or business relocations are anticipated. The proposed ROW required for the Preferred Alternative is shown in the concept plans provided in **Appendix B**.

### **6.5 Horizontal and Vertical Alignment**

The horizontal alignment for the Preferred Alternative includes 10 horizontal curves within the project limits, summarized in **Table 6-1**. Plan sheets illustrating the Preferred Alternative are provided in **Appendix B**. The Preferred Alternative profile was raised approximately three feet to meet FDOT base clearance requirements. There is a proposed “sawtooth” profile to allow proper drainage of the curb and gutter sections. This increase in elevation is accommodated within the existing ROW with the exception of the one utility parcel impact at the northern project limits.

### **6.6 Bicycle and Pedestrian Accommodations**

The Preferred Alternative provides 10-foot shared use paths on both sides of the road for the full length of the project to enhance pedestrian and bicycle mobility. In addition, a 7-foot paved shoulder is provided for on-road bicyclists. The shared use paths are depicted in **Figure 6-1** and **Appendix B**.

Figure 6-2: Proposed Intersection Layout

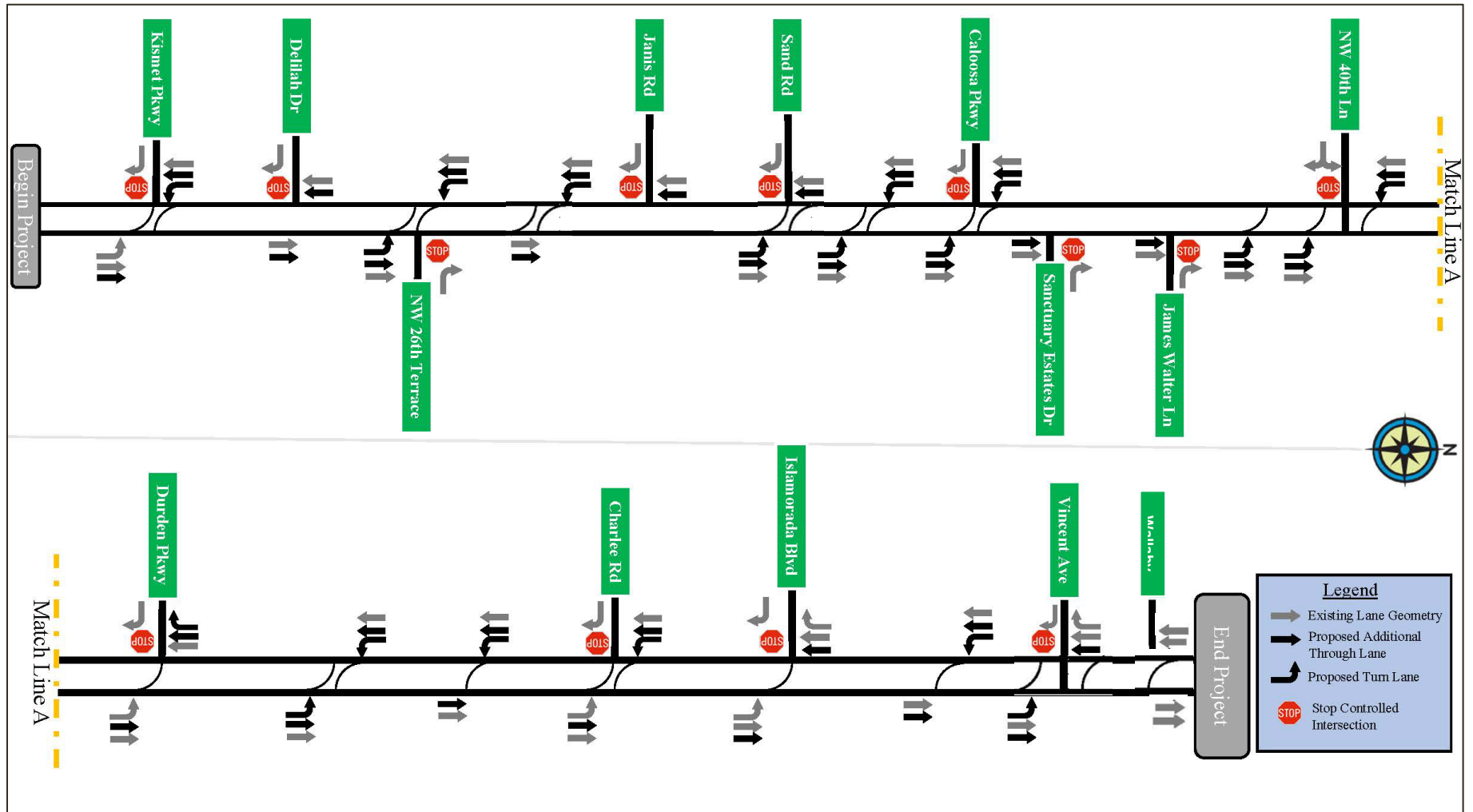

**Table 6-1: Proposed Horizontal Alignment**

Baseline PI Station	Bearing		Degree of Curvature	Radius	Length
	Back	Ahead			
1377+31.93	N 00° 01' 01" E	N 00° 18' 21" W	00° 02' 19"	148,003.15 ft	833.75 ft
1384+29.87	N 00° 18' 21" W	N 00° 14' 04" E	00° 02' 19"	148,003.15 ft	1,395.87 ft
1413+64.31	N 00° 14' 04" E	N 02° 35' 52" E	00° 27' 51"	12,345.37 ft	509.21 ft
1418+73.51	N 02° 35' 52" E	N 00° 14' 04" E	00° 27' 51"	12,345.37 ft	509.21 ft
1479+15.65	N 00° 14' 04" E	N 01° 46' 10" E	00° 17' 11"	20,000.00 ft	267.90 ft
1532+55.75	N 01° 46' 10" E	N 01° 02' 55" E	00° 09' 49"	35,000.00 ft	440.24 ft
1563+32.89	N 01° 02' 55" E	N 02° 52' 21" E	00° 19' 39"	17,500.00 ft	557.09 ft
1578+95.97	N 02° 52' 21" E	N 01° 02' 59" W	00° 19' 39"	17,500.00 ft	1,198.00 ft
1588+24.56	N 01° 02' 59" W	N 02° 47' 28" E	00° 38' 11"	9,004.90 ft	603.66 ft
1593+45.66	N 02° 47' 28" E	N 00° 00' 00" E	00° 38' 11"	9,004.90 ft	438.64 ft
1377+31.93	N 00° 01' 01" E	N 00° 18' 21" W	00° 02' 19"	148,003.15 ft	833.75 ft
1384+29.87	N 00° 18' 21" W	N 00° 14' 04" E	00° 02' 19"	148,003.15 ft	1,395.87 ft
1413+64.31	N 00° 14' 04" E	N 02° 35' 52" E	00° 27' 51"	12,345.37 ft	509.21 ft
1418+73.51	N 02° 35' 52" E	N 00° 14' 04" E	00° 27' 51"	12,345.37 ft	509.21 ft

## 6.7 Future Traffic Conditions

The *Project Traffic Analysis Report* (August 2022) documents the operational and safety analysis conducted for the PD&E study. The future years of analysis include both opening year (2025) and design year (2045). No analysis for interim year was expected for this project. Per the Department's direction, the link level analyses were included in the PTAR, and no future intersection analyses were evaluated.

### 6.7.1 Opening Year (2025) and Design Year (2045) Traffic Volumes

The recommended growth rates used in the future traffic volumes development process for this project are 5.5% for the No-Build Alternative, 8.2% for the Build Alternative, and 2.7% for all side streets for both the No-Build and Build Alternative (as shown previously in **Table 4-1**). The approved Turning Movement Volumes for the Build opening year (2025) and design year (2045) for the study intersections are provided in **Appendix D**.

### 6.7.2 Opening Year (2025) and Design Year (2045) Traffic Operational Analysis

Under the Build Alternative, Burnt Store Road within the project limits was evaluated as a four-lane divided facility. Also, the approved Access Management Resolution developed by Lee County was used to include the proposed access points within the project corridor under the Build Alternative. Since the Lee County Access Management Resolution designates Burnt Store Road as a controlled access road and dictates the access points and the intersection configurations, no intersection analyses were included in this study. No Intersection Control Evaluation (ICE) was conducted in this study, as recommended by the District Traffic Operations Group. Therefore, the link level analyses for the Build Alternative were only included, as agreed by the District Systems Planning Office.

As stated in **Section 4.3**, all future AADT volumes were linearly projected using a recommended growth rate of 8.2% for the Build Alternative, then rounded using the AASHTO rounding convention. The AADT

volumes and the recommended K and D factors were used to calculate the daily design hour volumes (DDHVs) for each segment as shown previously in **Table 4-4** and **Table 4-5** for the opening year and the design year, respectively. The LOS measure for the segments under the Build Alternative (four-lanes divided) was developed by comparing the calculated DDHVs with the threshold volumes from the Link Service Volumes on Arterials developed by Lee County as agreed by the Department.

The Build Alternative for both opening year (2025) and design year (2045) show an acceptable LOS or better, and a V/C ratio less than 0.85 which indicates that adequate roadway capacity is available, and vehicles are not expected to experience significant queues and delays. A LOS F is a failing operating condition; a LOS D or better is an acceptable condition. As discussed in the PTAR, the LOS standard for Burnt Store Road is E and this is based on the 2022 Link Service Volumes on Arterials developed by Lee County, as referenced in the Public Facilities Level of Service and Concurrency Report, 2022 Inventory and Projections. These service volumes are based on the FDOT Level of Service tables.

## 6.8 Preliminary Drainage Analysis

### 6.8.1 Hydraulics

A *Location Hydraulics Report* (February 2023) was prepared under separate cover. This document was prepared to assess base floodplain encroachments resulting from the proposed roadway improvements. A preliminary evaluation of the cross drains was conducted to determine whether the existing cross drains would have adequate capacity if they were lengthened. Cross drain extensions included in this project will result in an insignificant change in their capacity to carry floodwater. These modifications will cause minimal increases in flood heights and flood limits which will not result in any significant adverse impacts on the natural and beneficial floodplain values or any significant change in flood risk or damage. There will be no negative effect in the potential for interruption or termination of emergency service or emergency evacuation routes as the result of modifications to existing drainage structures.

**Table 6-2** provides a summary of the proposed cross drain improvements. Although most are currently recommended to be extended rather than replaced, this should be analyzed further during the design phase based on the latest culvert inspection reports and history of maintenance/repairs for each cross drain.

**Table 6-2: Summary of Proposed Cross Drain Modifications**

Cross Drain	Barrels	Size	Existing Length (ft)	Proposed Modification	Approximate Proposed Length (ft)	Station
CD-2	4	36"	49	Extension	184	1333+08
CD-3	2	30"	53	Extension	184	1347+12
CD-4	4	24" x 38"	85	Extension	185	1380+11
CD-5	3	30"	84	Extension	155	1435+11
CD-6	4	24"	44	Extension	175	1466+08
CD-7	4	48"	90	Extension	187	1492+87
CD-8	2	30"	47	Extension	178	1507+31
CD-9	2	9' x 8'	62	Replacement	140	1538+06
CD-10L	1	10' x 5'	42	Extension	171	1582+09
CD-10C	1	7' x 4'	106	Extension	193	1591+18

The Federal Emergency Management Agency (FEMA) identifies flood hazards, assesses flood risk and provides accurate data to guide stakeholders in taking effective mitigation actions which would increase public safety. A review of the FEMA Flood Insurance Rate Maps (FIRM) for the project area indicates that the northern project area mainly lies outside the 100-year floodplain while the southern project area is primarily identified as Zone AE. Additionally, no portions of the project lie within a regulated floodway. **Figure 2-9** depicts the floodplains with the study area (2003/2008 FIRMs). During the course of this PD&E Study, the FEMA FIRMs were updated. **Appendix F** provides a floodplain update memorandum. The project will be designed to the most current floodplain requirements.

The project will impact the 100-year floodplain through longitudinal and transverse impacts. The longitudinal impacts result from filling floodplain areas associated with the proposed roadway widening. Transverse impacts result from the extension and replacement of existing cross drains. The floodplain encroachment areas were quantified based on the FEMA 100-year floodplain elevations, estimated seasonal high water table, and existing ground elevations using 1-foot LiDAR contours. The proposed profile grades were used to estimate the floodplain impacts. These impacts may increase during the design phase if modifications to the profile are necessary.

Floodplain impacts were estimated using the cup-for-cup method to determine potential impacts to the 100-year floodplain and necessary compensation volumes. The exact impact volume will need to be assessed during the design phase when survey and geotechnical data become available. Floodplain impacts will be mitigated in a site designated as Pond 2 and Floodplain Compensation Area. In addition, Pond 2C, the preferred pond site for Basin 2, will be used for floodplain compensation, treatment, and attenuation (**Appendix B**). Also during the design phase, the conveyance ditch on the west side of the roadway should be optimized within the ROW to provide the maximum allowable floodplain compensation volume. Ponds 2A and 2B are options to provide additional floodplain compensation if needed. The Basin 2 ponds were conservatively sized to compensate for the floodplain impact per encroachment area. As detailed in the *LHR* and floodplain update memorandum (**Appendix F**), the conceptual design results in 8.24-25.07 acre-feet of impact, with the higher limit based on tidal stillwater elevations (updated FIRM).

Per the FDOT PD&E Manual, the floodplain encroachment areas are classified as minimal. Minimal encroachments on a floodplain occur when there is floodplain involvement but the impacts on human life, transportation facilities, and natural and beneficial floodplain values are not significant and can be resolved with minimal efforts. Normally, these minimal efforts to address impacts consist of applying FDOT's drainage design standards and following the WMD's procedures to achieve results that will not increase or significantly change the flood elevations and/or limits.

### **6.8.2 Stormwater Management**

A *PSR* (March 2023) was prepared under separate cover. The purpose of the report is to present potential pond site locations for meeting applicable stormwater management criteria and identify right-of-way needs for the project. The report documents the evaluation of the 11 basins, three pond alternatives per basin with the exception of basin 7 and basin 10, and the identified preferred pond alternatives. Basin 7 was excluded due to the ecological sensitivity of the majority of the land within it, part of the Yucca Pens. Additional compensatory treatment can alternatively be provided in basins 6 and 8 and ditch blocks within basin 7 can provide attenuation. Basin 10 was divided into the Lee and Charlotte components with one

option for basin 10-L and two options for basin 10-C. A pond site designated only for additional floodplain compensation area, identified as Pond 2, was also evaluated in basin 2.

The ponds were sized using a volumetric approach where the water quality and quantity volume were added. An additional 50% of the treatment volume was added to the required treatment volume as a conservative approach. However, it was concluded in discussions with the SFWMD that since the project does not directly discharge to an Outstanding Florida Water (OFW), additional treatment is not required. In addition, the stormwater management ponds were sized to accommodate the future 6-lane condition for the roadway. The pond sizes, sites and layouts are preliminary and were determined using the best available data collected for the PD&E Study. The pond design will be finalized during the design phase when site-specific data is available.

**Table 6-3** provides a summary of the ROW requirements associated with each of the recommended pond sites. The locations of the pond and floodplain compensation sites are shown in the Preferred Alternative Concept Plans in **Appendix B**. The sizes of these facilities were estimated using SFWMD and FDOT water quality treatment and attenuation requirements. Approximately 47.10 acres of ROW will be needed for the stormwater management facilities.

Stormwater runoff from the road facility will be collected and conveyed to the recommended stormwater ponds within each basin through a closed stormwater drain system (curb and gutter design). The ditch on the east side of Burnt Store Road will be replaced with a conveyance pipe to ensure the existing drainage patterns are maintained. To capture offsite flows, a series of inlets will be strategically placed along the east side of Burnt Store Road to direct runoff to Gator Slough and prevent comingling of offsite runoff with roadway runoff. The pipe is anticipated to be sized, during the design phase, based solely on the existing conveyance of the east side ditch. The ditch on the west side of Burnt Store Road will remain to ensure the existing drainage patterns are maintained.

**Table 6-3: Summary of Preferred Pond Sites**

Basin	Preferred Pond	Size (Acres)
1	1A	3.30
2	2C	4.34
2	Pond 2 (for floodplain compensation)	11.88
3	3C	1.77
4	4B	3.37
5	5A	9.40
6	6A	3.03
7	-	0.00
8	8B	2.62
9	9C	5.03
10-L	10A	2.36
10-C	10C	N/A (existing pond)
<b>Total</b>		<b>47.1</b>

A *Water Quality Impact Evaluation (WQIE)* (August 2022) was prepared under separate cover. The Preferred Alternative is expected to have no significant impact on water quality and quantity.

## 6.9 Structural Analysis

The recommended alternative for Bridge No. 120025, the southbound bridge over Gator Slough Canal, is Option 1, which proposes replacement of the bridge structure. This option will provide for a bridge structure with a low member elevation that accounts for sea level rise, drift clearance, and has a higher debris potential given pilings in line with the existing northbound bridge. Additionally, since the roadway construction involves raising the profile by approximately three feet to account for the high seasonal high-water table, construction of Option 1 will allow for the complete roadway profile grade change, including the approaches to the new southbound bridge. Option 2, which would delay the bridge replacement, would require a more extensive bridge replacement project in the future, including “throw-away” of the adjacent new roadway construction including the bridge approaches as the profile would need to be raised at that time. A rendering of this alternative is provided in **Figure 6-3**.

**Figure 6-3: Bridge No. 120025 Recommended Alternative (four-lane configuration)**

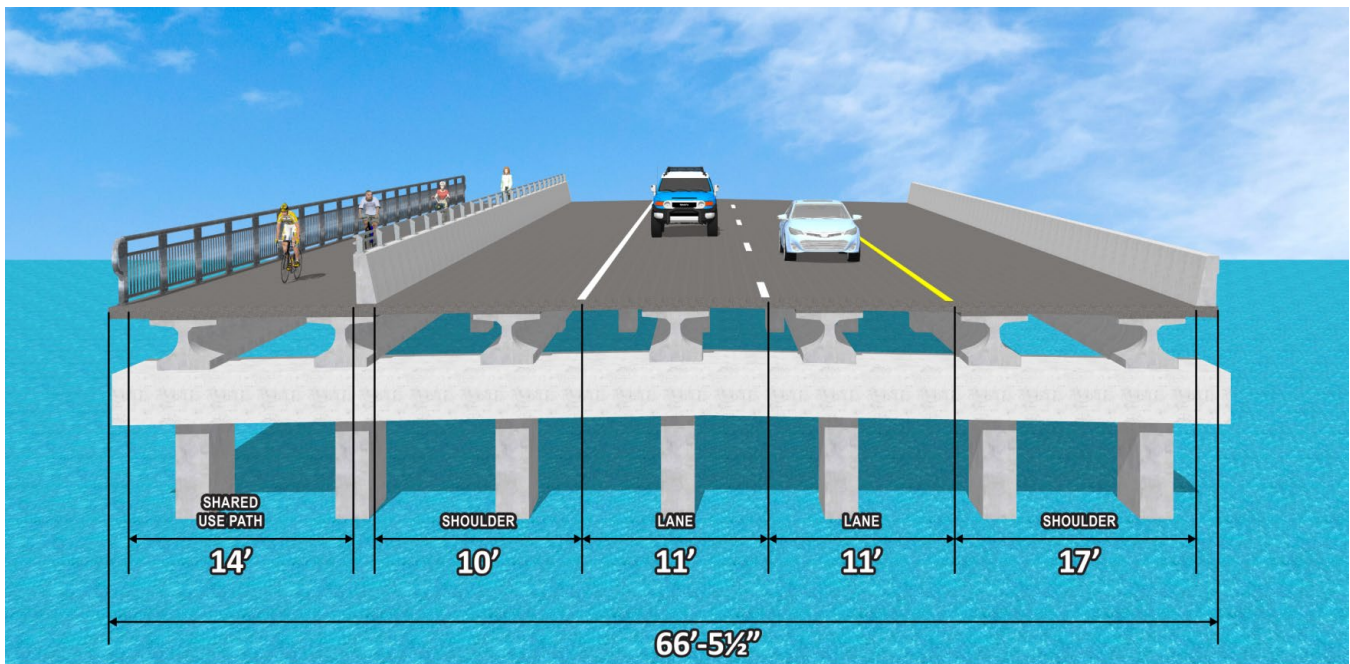

**The recommended alternative for Bridge No. 120054 (Burnt Store Road over Yucca Pen Creek) is Option 1, which involves replacement in-kind with a double 10' x 8' concrete culvert. This option will require dewatering of the creek, one cell at a time or a temporary creek diversion. While Option 2 was initially considered, new bridge construction would add significant and unnecessary cost to the project.**



## 6.10 Utility Impacts

Widening Burnt Store Road may require some relocation of utilities within the existing ROW. Coordination with potentially affected utilities owners will occur throughout the future project design and construction phases. Project design will seek to avoid and minimize impacts to existing utilities to the extent feasible. The utility agencies/owners known to operate utilities within the project corridor are shown in **Table 6-4**.

**Table 6-4: Preferred Alternative Potential Utility Conflicts**

Company	Contact	Utilities
Charlotte County Lighting District	Andrew Amendola (941) 575-3648 or (941) 628-9301 Andy.Amendola@charlottecountyfl.gov	Buried electric on west side in Charlotte Co. and on east side at very northern limit in Charlotte Co.
Charlotte County Utilities	Hendrik Dolleman (941) 286-7198 or (941) 883-3521 Hendrik.Dolleman@charlottecountyfl.gov	Buried water, wastewater, and reclaimed water mains on west side from 40 <sup>th</sup> Street to north end of project and crossing road and on east side at northern limit in Charlotte Co.
Comcast	Steve Hutson (239) 672-1171 steve_hutson@comcast.com	Overhead cable on electric poles on west side and on several side streets to the west; buried cable on west side in several locations and crossing road at northern limit in Charlotte Co.
Crown Castle Fiber	Danny Haskett (786) 610-7073 or (786) 246-7827 Danny.Haskett@crowncastle.com	Overhead fiber on electric poles on east side at northern limit in Charlotte Co.; buried fiber on west side at south end, crosses road in two locations, and on east side at northern limit in Charlotte Co.
Florida Power and Light	Chris McJunkin (941) 423-4833 Chris.McJunkin@FPL.com	Overhead electric crosses road just north of Vincent Ave. and at Wallaby Ln. and runs on east side to the north project limit (Charlotte Co.)
Lee County Electric Cooperative	Keith Lanman (239) 656-2414 or (239) 281-6265 Keith.Lanman@lcec.net	Overhead electric on west side with road crossings in several locations; buried electric on west side at Islamorada Blvd.
Lee County Signal Department	Ryan Kirsch (239) 533-9512 RKirsch@leegov.com	Buried electric on east and west sides from southern project limit to Delilah Dr.
Lumen (previously CenturyLink)	Ezekiel Reid (239) 791-1299 Ezekiel.Reid1@lumen.com	Utility parcel with building/hub on east side just north of Lee County Line; buried fiber optic on west side at south and north ends of project; several roadway crossings; overhead telephone on west side in several locations; buried telephone on majority of west side with crossings in two locations

## 6.11 Cost Estimates

The project costs estimated for the Preferred Alternative are summarized in **Table 6-5**. The construction costs were updated in December 2024 using the FDOT’s Long Range Estimating (LRE) program and are provided in **Appendix C**. Costs are detailed by county.

**Table 6-5: Project Cost Estimate**

Estimated Project Costs	No-Build Alternative (in millions)	Preferred Alternative Lee County	Preferred Alternative Charlotte County
Final Design	\$0	\$12,799,000	\$601,000
Wetland Mitigation	\$0	\$2,525,000	\$0
Right-of-Way Acquisition	\$0	\$25,500,000	\$1,035,000
Construction	\$0	\$127,990,000	\$6,005,000
Construction Engineering and Inspection	\$0	\$12,799,000	\$601,000
Preliminary Estimate of Total Project Cost	\$0	\$181,613,000	\$8,242,000

\*ROW cost estimates were prepared by FDOT for Charlotte County parcels and Lee County for Lee County parcels, in November 2024. Construction cost estimates reflect December 2024 unit costs.

## 6.12 Summary of Environmental Impacts

This section documents the potential environmental impacts for the Preferred Alternative. As described previously in Section 1.1, the project was screened through Environmental Screening Tool (EST) as part of the Efficient Transportation Decision Making (ETDM) Programming Screen phase (ETDM #14223) and no major issues or disputes were noted by the Environmental Technical Advisory Team (ETAT). The *Programming Screen Summary Report*, prepared under separate cover, was published on September 4, 2020 and re-published on March 10, 2023 with the approved Class of Action (COA) of a Type 2 Categorical Exclusion (Type 2 CE).

Of the 21 environmental topics analyzed, two received a Degree of Effect of 1 (enhanced), fifteen received a Degree of Effect of 2 (Minimal) and five received a Degree of Effect of 3 (Moderate). These five topics include: Farmlands, Section 4(f) Potential, Historic and Archaeological Sites, Wetlands and Surface Waters, and Wildlife and Habitat.

### 6.12.1 Farmlands

A Farmland Conversion Impact Rating for Corridor Type Projects Form (NRCS-CPA-106) was prepared for this project. Through coordination with the NRCS, the Preferred Alternative will impact 11.40 acres of farmland with a total corridor assessment point value of 55.3 points. Corridors receiving a total score of less than 160 points do not require further consideration or coordination. The NRCS-CPA-106 form was finalized on January 9, 2023.

### 6.12.2 Historic Resources and Archaeological

A *Cultural Resource Assessment Survey* (July 2022) was prepared under separate cover. It was provided to the State Historic Preservation Office (SHPO) on July 27, 2022. SHPO concurred with the findings on August 17, 2022. Additionally, a CRAS Addendum was prepared under separate cover in December 2022 to address the proposed offsite stormwater management facilities. SHPO similarly concurred with

the findings of the *Cultural Resource Assessment Survey Addendum* on February 6, 2023. No significant cultural resources, including archaeological sites and historic resources are listed, determined eligible, or considered potentially eligible for listing in the National Register of Historic Places (NRHP) within the project Area of Potential Effect (APE). A Section 106 Case Study Report was not required for this project.

Archaeological background research and a review of the Florida Master Site File (FMSF) and the NRHP indicated that no previously recorded archaeological sites are within the APE. However, two sites are recorded within one mile: one prehistoric (8LL02416, Yucca Pen Creek Site) and one historic archaeological site (8LL02417, the Yucca Pen Cabin). The State Historic Preservation Officer (SHPO) determined both sites not eligible for listing in the NRHP. As a result of the field survey of the APE, which had a low to moderate archaeological potential, no archaeological sites were found.

Historic background research indicated that one historic resource (8CH01589) was previously recorded within the APE. A previously recorded segment of Burnt Store Road was identified at the northern terminus the APE in Charlotte County (8CH01589); however, the resource had not been evaluated previously by the SHPO. An unrecorded segment of the previously recorded linear resource, the Gator Slough Canal (8LL02469), is located within the historical APE. The segment of the Gator Slough Canal (8LL02469) identified outside of the APE was determined ineligible for listing in the NRHP by the SHPO. As a result of the historical/architectural field survey, nine historic resources (8LL02869 – 8LL02877) were newly identified, recorded, and evaluated, and two previously recorded historic resources were updated (8LL02469 and 8CH01589). These include one bridge and seven culverts (8LL02869 – 8LL02876), and three linear resources, a newly identified segment of Burnt Store Road (8LL02877) in Lee County, an updated segment of Burnt Store Road (8CH01589) in Charlotte County, and a newly identified segment of the previously recorded Gator Slough Canal (8LL02469). Overall, the historic resources are of common design, lack significant attributes and have no known historic associations with significant persons and/or events. The bridges and culverts on this project are common examples of post-1945 concrete culvert and slab bridge construction built between 1965 and 1972. These types of resources are exempt from consideration under Section 106 of the National Historic Preservation Act.

### **6.12.3 Section 4(f)**

Potentially protected Section 4(f) resources along the project corridor include: Fred C. Babcock/Cecil M. Webb Wildlife Management Area- Yucca Pens Unit, Charlotte Harbor Preserve State Park, Charlotte Harbor Buffer Preserve, Yucca Pens Preserve, Burnt Store Trail, and Charlotte County Spine Trail 2. The Preferred Alternative does not impact any of these resources. Therefore, the Preferred Alternative is expected to have no significant impact to sites protected under Section 4(f) of the U.S. Department of Transportation Act of 1966, as amended, and 23 CFR Part 774.

The Babcock/Webb Wildlife Management Area consists of the Webb Tract, containing 65,758 acres, and the Yucca Pens Unit, consisting of 15,014 acres. The Yucca Pens Unit is located within southern Charlotte County and northwest Lee County. Burnt Store Road is a western property border in areas where the property extends that far west. The property provides ecological diversity and managed habitat for both imperiled and common wildlife, and for providing the public with fish and wildlife-based public outdoor recreational opportunities. There are no public access points from Burnt Store Road. The Preferred Alternative does not require any ROW from the property. Driveways have been depicted in the

roadway concept plans, connecting to the existing maintenance access gates. Therefore, maintenance staff will continue to be able to access the properties in the post-project condition.

Yucca Pens Preserve is a 232-acre preserve owned by the Lee County Board of County Commissioners and managed by the Lee County Conservation 20/20 program, through the Department of Parks and Recreation. The preserve consists of five parcels, broken into three tracts along the east side of Burnt Store Road. The southern-most parcel is just north of James Walter Lane, the middle parcel is across from Durden Parkway, and the northern-most parcel is located just south of the Charlotte County Line. Yucca Pens Preserve offers only resource-based recreational opportunities, with public access available only at the southern of the three parcels, through a walk-through gate. The Preferred Alternative does not require any ROW from the property. Driveways have been depicted in the roadway concept plans, connecting to the existing maintenance access gates, to allow for continued maintenance staff access. A small parking area likely would be required within the parcel boundary to continue to accommodate public parking, since parking in the road right-of-way will not be possible with the proposed project.

Charlotte Harbor Preserve State Park consists of 42,598.06 acres and includes many discontinuous parcels that stretch around Charlotte Harbor, portions of which are included within the incorporated boundaries of Punta Gorda and Cape Coral. There is no central point of entry for the public, with access provided at a collection of trailheads and gates throughout the boundary of the preserve. Public outdoor recreation and conservation is the designated single use of the property. The Cape Coral North Management Area contains the portion of the park located on the west side of Burnt Store Road, south of Charlee Road. There is a maintenance gate situated at this location but there is no designated public access from Burnt Store Road. The Preferred Alternative does not require any ROW from the property. A driveway has been depicted in the roadway concept plans, connecting to the existing maintenance gate. Therefore, maintenance staff will continue to be able to access the properties in the post-project condition.

Charlotte Harbor Buffer Preserve is a 450-acre preserve similarly owned by the Lee County Board of County Commissioners and managed by the Lee County Conservation 20/20 program, through the Department of Parks and Recreation. In addition, portions of the preserve are co-managed with the Florida Department of Environmental Protection and the adjacent Charlotte Harbor Preserve State Park. There is one area where the property is adjacent to the west side of Burnt Store Road; in this location, it is immediately south of and contiguous to the state park, south of Charlee Road. Charlotte Harbor Buffer Preserve offers only resource-based recreational opportunities, with public access available only at two locations. One location is along the west side of Burnt Store Road, through a walk-through gate. In addition, Lee County staff currently has two maintenance access gates into this property from Burnt Store Road. The Preferred Alternative does not require any ROW from the property. Driveways have been depicted in the roadway concept plans, connecting to the existing maintenance access gates, to allow for continued maintenance staff access. A small parking area likely would be required within the parcel boundary to continue to accommodate public parking, since parking in the road right-of-way will not be possible with the proposed project.

These four resources meet the conditions of a “No Section 4(f) Use” since the project has no permanent acquisition of land from a Section 4(f) property, no temporary occupancies of land that are adverse in terms of the statute’s preservation purpose, and no proximity impacts which significantly impair the

protected functions of the property. Section 4(f) No Use Determination forms were completed for these resources.

The Charlotte County Spine Trail 2 consists of a six-foot wide concrete sidewalk that was recently constructed as part of the Charlotte County roadway widening project of Burnt Store Road. There is sidewalk on both the east and west sides of the road. The trail begins at Wallaby Lane, the northern limit of this study, and continues approximately 2.45 miles north to Zemel Road beyond the project limits. This portion is coded as an existing trail within the SUN Trail network, however as a six-foot wide trail, it does not meet SUN Trail criteria. Recreational opportunities on this trail include walking, running, and bicycling. The Burnt Store Trail consists of a variable width concrete or asphalt pathway that was recently constructed as part of the Lee County roadway widening project of Burnt Store Road. The trail begins at Van Buren Parkway where it is ten feet in width and continues on the east side of Burnt Store Road approximately 2,000 feet north to just south of Kismet Parkway. In this northern section, the trail is twelve feet wide. This trail segment is coded as an existing trail within the SUN Trail network. On the west side of Burnt Store Road, trail is lacking; there is a concrete sidewalk that begins as ten feet wide but then transitions to five feet wide.

An exception/exemption to the requirements for a Section 4(f) approval was determined to apply to these trail resources because they meet the circumstances of 23 CFR Section 774.113 (f) part 4- Trails, paths, bikeways, and sidewalks that are part of the local transportation system and which function primarily for transportation. There may be temporary construction impacts in the vicinity of the trail connection locations given the roadway construction. However, this will be temporary and of short duration, and there will be no adverse impacts. Instead, this roadway project will help to enhance both trail resources by connecting an additional 5.5 miles of new shared-use path which will extend bicycle and pedestrian opportunities along Burnt Store Road and connect the trails to other existing trails in the area. Section 4(f) Exceptions/Exemptions Determination forms were completed for these resources.

#### **6.12.4 Natural Resources**

##### **6.12.4.1 Wetlands and Other Surface Waters**

A *Natural Resources Evaluation* (February 2023) was prepared under separate cover as part of this project to analyze anticipated impacts of the Preferred Alternative on wetland resources, to ensure their protection to the extent practicable, and to determine appropriate mitigation. There are no wetlands or surface waters designated as OFW or Aquatic Preserves (AP) within the project study area. The primary wetland resource in the project footprint is roadside ditches. These systems are excavated, linear features which support hydrophytic (wetland) vegetation. Forested wetlands, consisting of hydric pine flatwoods and mixed wetland hardwoods, are the next most common system, followed by herbaceous wetlands (wet prairies, marshes, and wetland shrub systems) and by forested wetlands that are infested with nuisance, exotic vegetation (melaleuca and Brazilian pepper).

The Preferred Alternative will result in a total of 22.06 acres of impact to wetlands, surface waters, and other surface waters for the mainline improvements and 11.40 acres of impact to wetlands and other surface waters for the preferred pond sites (**Table 6-6**). This totals 33.46 acres. The final area of wetland impacts will be determined during the design and permitting phase of the project. A Uniform Mitigation Assessment Method (UMAM) analysis was performed to determine an estimate of the wetland system functional loss associated with the proposed Preferred Alternative. The impacts are anticipated to result

in a loss of 12.64 units. Additional functional loss may be required by the permitting agencies for other potential impact types (e.g. secondary impacts). The project is located within the service area of Little Pine Island Mitigation Bank (LPIMB), which offers the appropriate credit types and is the only bank option at the time of this report. The project is located within the Tidal Caloosahatchee basin; the LPIMB is not located within a designated cumulative impact drainage basin. Therefore, while it is possible that a Cumulative Impact Analysis will be required by the SFWMD to demonstrate that credit purchase from this bank is appropriate given its location outside of the Tidal Caloosahatchee Basin, it is anticipated that this mitigation bank will be satisfactory for SFWMD permitting. The USACE does not consider drainage basins, but instead mitigation bank service areas and wood stork CFA as part of the geographical component of the mitigation assessment. It is anticipated that this mitigation bank will therefore be satisfactory for USACE permitting since the project shares wood stork CFAs with the bank. At this time, credits are available; however, the status of available mitigation banks and credits will be re-assessed as this project moves forward into design and permitting. Mitigation will be addressed pursuant to Chapter 373.4137, Florida Statutes (F.S.) in order to satisfy all mitigation requirements of Part IV, Chapter 373, F.S. and 33 U.S.C. §1344. Therefore, the Preferred Alternative will have no significant impact on wetlands.

**Table 6-6: Anticipated Wetland and Surface Water Impacts**

<b>System Type</b>	<b>Preferred Alternative Impacts (acres)</b>	<b>Preferred Ponds Impacts (acres)</b>
Herbaceous wetlands (marsh, wetland shrub, wet prairie)	3.96	1.05
Forested wetlands (hydric pine flatwoods, mixed wetland hardwoods)	0.62	4.96
Exotic forested wetlands (melaleuca and/or Brazilian pepper-dominated)	0.25	2.98
Other Surface Waters (roadside ditches, reservoirs)	17.22	2.42
Surface Waters (channelized waterways/canals)	0.02	0.00
<b>Totals</b>	<b>22.06</b>	<b>11.40</b>

Note: The totals reflect individual system acreages and any apparent sum differences are due to rounding.

**6.12.4.2 Essential Fish Habitat**

The proposed project is within the Gulf of Mexico Fishery Management Council (GMFMC) area of jurisdiction. Essential Fish Habitat (EFH) within the project area includes Gator Slough Canal. There is no submerged aquatic vegetation (e.g. seagrass), mangroves, or shellfish habitat identified within the project study area. Due to the nature of the project, no populations of any of the 55 managed species listed by the GMFMC or the 48 highly migratory species listed by National Marine Fisheries Service are expected to be adversely affected by the proposed project. The project is anticipated to have minimal effects on EFH.

**6.12.4.3 Protected Species and Habitat**

A *Natural Resources Evaluation* (February 2023) was prepared under separate cover as part of this project to analyze and document the effects of the Preferred Alternative on federal and state protected

species and their habitats. The *Natural Resources Evaluation* was submitted to state and federal permitting and commenting agencies on February 13, 2023. Comments were received from the NMFS, USFWS, FWC, USEPA, SFWMD, and FDACS. Federal listed species determinations of effect were changed from “may affect, not likely to adversely affect” to “no effect” by the USFWS for the crested caracara, snail kite, Florida scrub-jay, and red-cockaded woodpecker due to lack of suitable habitat. The effect determination for the Florida bonneted bat was proposed as “may affect, not likely to adversely affect- Consultation” using the 2019 Consultation Key for the Florida Bonneted Bat, meaning that informal consultation was required with USFWS. Informal consultation was completed with the USFWS on February 14, 2023. The NMFS indicated that since construction details for the new southbound bridge over Gator Slough Canal are not known at this time, consultation will be completed later during the final design project phase. **Table 6-7** and **Table 6-8** summarize the effect determinations for federally and state listed species, respectively. Several project commitments and implementation measures will help to protect species prior to and during construction. The Preferred Alternative will not adversely impact any listed species or federally-designated Critical Habitat.

**Table 6-7: Summary of Federally Listed Species and Critical Habitat Effect Determinations**

Project Effect Determination	Federal Species or Critical Habitat
No effect	American crocodile ( <i>Crocodylus acutus</i> ) Loggerhead sea turtle ( <i>Caretta caretta</i> ) Green sea turtle ( <i>Chelonia mydas</i> ) Leatherback sea turtle ( <i>Dermochelys coriacea</i> ) Hawksbill sea turtle ( <i>Eretmochelys imbricata</i> ) Red-cockaded woodpecker ( <i>Picoides borealis</i> ) Snail kite ( <i>Rostrhamus sociabilis plumbeus</i> ) Florida scrub-jay ( <i>Aphelocoma coerulescens</i> ) Crested caracara ( <i>Caracara plancus audubonii</i> ) Piping plover ( <i>Charadrius melodus</i> ) Eastern black rail ( <i>Laterallus jamaicensis</i> ) Rufus red knot ( <i>Calidris canatus rufa</i> ) Florida panther ( <i>Puma concolor coryi</i> ) Beautiful pawpaw ( <i>Deeringothamnus pulchellus</i> ) Aboriginal prickly apple ( <i>Harrisia aboriginum</i> )
May affect, not likely to adversely affect	Eastern indigo snake ( <i>Drymarchon corais couperi</i> ) Wood stork ( <i>Mycteria americana</i> ) West Indian manatee ( <i>Trichechus manatus</i> ) Gulf sturgeon ( <i>Acipenser oxyrinchus desotoi</i> ) Smalltooth sawfish ( <i>Pristis pectinata</i> )
May affect, not likely to adversely affect – C	Florida bonneted bat ( <i>Eumops floridanus</i> )
No adverse modification or destruction of Critical Habitat	Smalltooth sawfish Critical Habitat West Indian manatee Critical Habitat
No adverse modification or destruction of proposed Critical Habitat	Florida bonneted bat Critical Habitat

**Table 6-8: Summary of State Listed Species Effect Determinations**

Project Effect Determination	State Species
No effect anticipated	Least tern ( <i>Sternula antillarum</i> ) Snowy plover ( <i>Charadrius nivosus</i> ) Sand-dune spurge ( <i>Euphorbia cumulicola</i> ) Spreading pinweed ( <i>Lechea divaricata</i> ) Nodding pinweed ( <i>Lechea cernua</i> )
No adverse effect anticipated	Florida pine snake ( <i>Pituophis melanoleucus mugitus</i> ) Florida sandhill crane ( <i>Antigone canadensis pratensis</i> ) Florida burrowing owl ( <i>Athene cunicularia floridana</i> ) Little blue heron ( <i>Egretta caerulea</i> ) Reddish egret ( <i>Egretta rufescens</i> ) Tricolored heron ( <i>Egretta tricolor</i> ) Southeastern American kestrel ( <i>Falco sparverius paulus</i> ) Roseate spoonbill ( <i>Platalea ajaja</i> ) Sherman's short-tailed shrew ( <i>Blarina carolinensis shermani</i> ) Florida beargrass ( <i>Nolina atopocarpa</i> ) Many-flowered grass-pink ( <i>Calopogon multiflorus</i> )

**6.12.4.4 Wildlife Features**

A wildlife feature such as a culvert modification was considered for the project. The Yucca Pen Creek location is a viable option to provide passage for unprotected wildlife such as small and medium-sized mammals, reptiles and amphibians. This location was considered due to its size and regional habitat connectivity. Since the bridge culvert is proposed for replacement, the new structure could include a cantilevered concrete slab on the side of one culvert wall or could include a third box that would contain a built-up berm/shelf. Alternatively, a wildlife feature could be sited elsewhere along the project limits to include a pipe (e.g. two to three foot diameter) with an invert elevation higher than the seasonal high water elevation to provide dry passage. Lee County will further evaluate the viability of including a wildlife feature within the project during final design.

**6.12.5 Contamination**

A *Contamination Screening Evaluation Report* (January 2023) was prepared for the study. A total of six potentially contaminated and/or known to be contaminated sites were identified within the search distance buffers (500 feet of the edge of the project limits for petroleum, drycleaners, and non-petroleum sites; 1,000 feet for non-landfill solid waste sites; and 0.5 miles for Comprehensive Environmental Response, Compensation and Liability Act, National priorities list, Superfund sites, and landfill sites). Risk evaluation ratings include no *High Risk* rating sites, two *Medium Risk* rating sites, four *Low Risk* rating sites and zero *No Risk* rating sites for potential contamination concerns. Level II Contamination Assessment investigations are recommended for any areas that have proposed dewatering or subsurface work activities occurring adjacent to or at any medium or high risk sites identified.



### 6.12.6 Air Quality

This project is not expected to create adverse impacts to air quality since the project area is in attainment for all National Ambient Air Quality Standards (NAAQS). Additionally, the project will reduce traffic congestion and delays, and improve the LOS, thus reducing vehicle emissions.

### 6.12.7 Highway Traffic Noise

A *Noise Study Report* (December 2024) was prepared for this study to document the results of the analysis performed for the project to identify land uses for which there are FHWA Noise Abatement Criteria (NAC) that would be impacted by highway traffic noise in the design year with the improved roadway. Traffic noise levels were predicted for the existing conditions (2021) and future conditions (2045) without the proposed improvements (the No-Build Alternative) and with the improvements (the Preferred Alternative). The results of the highway traffic noise analysis indicate that five residences would be impacted in the future with the Preferred Alternative for the proposed improvements. Noise abatement measures were considered for the impacted residences. These measures included traffic management, alignment modification, buffer zones, and noise barriers. Two of these residences, receptors 3 and 6, are located between NW 20th Lane and Gator Slough Canal. A noise barrier at this location could not achieve the required 5 dB(A) reduction or more to at least two impacted receptors, thus a barrier at this location is considered not feasible. The other three impacted residences, receptors 9, 71, and 82, are single isolated receptors located at Kismet Parkway, Dolphin Cove Drive in the Burnt Store Marina, and Wallaby Lane, respectively. Since these receptors are isolated, a barrier at these locations is also considered not feasible. Following the Highway Traffic Noise Chapter of the PD&E Manual, noise abatement measures were considered for the impacted properties. Based on the results of the evaluation, there are no measures that would be both feasible and reasonable to reduce/eliminate the predicted impact to the five residences.

### 6.12.8 Construction

Construction activities for the proposed project may cause minor short-term air quality, noise, water quality, traffic congestion, and visual impacts for nearby residents and the traveling public. The air quality effect will be temporary, localized, and will primarily be in the form of construction exhaust emissions and fugitive dust generated from equipment during project construction. Air pollution associated with the creation of airborne particles will be effectively controlled through the use of watering or the application of other controlled materials in accordance with FDOT's *Standard Specifications for Road and Bridge Construction*. USEPA listed other strategies in the EST summary that should be employed during project activities to reduce emissions, such as the use of diesel controls, cleaner fuel, and cleaner practices for construction equipment.

The residences in the vicinity of the Burnt Store Road Project are identified in the Highway Traffic Noise Chapter of the FDOT PD&E Manual as noise- and vibration-sensitive sites. Construction of the roadway improvements, with heavy equipment movement and other construction activities, is not expected to have a significant noise or vibration effect. Additionally, the application of the FDOT *Standard Specifications for Road and Bridge Construction* may minimize or eliminate any effect. Should unanticipated noise or vibration issues arise during the construction process, the Project Engineer, in coordination with a noise specialist and the contractor, will investigate additional methods of controlling these impacts.

Water quality impacts resulting from erosion and sedimentation will be controlled in accordance with the most current edition of the FDOT's *Standard Specifications for Road and Bridge Construction, "Prevention, Control, and Abatement of Erosion and Water Pollution,"* and through the use of best management practices (BMP). All state water quality criteria will be met. Short-term construction related wetland impacts will be minimized by adherence to FDOT's Standard Specifications for Road and Bridge Construction. These specifications include BMPs such as the use of siltation barriers, dewatering structures, and containment devices to control turbid water discharges outside of construction limits.

Maintenance of traffic and sequence of construction will be planned and scheduled so as to minimize traffic delays throughout the project. Signage will be used as appropriate to provide pertinent information to the traveling public. The local news media will be notified in advance of road closings and other construction related activities to allow for the planning of alternate routes. Access to local properties, businesses and residences will be maintained to the extent practical through controlled construction scheduling and the implementation of the project's specific Traffic Control Plan(s) and implementation of FDOT's *Standard Specifications for Road and Bridge Construction*. Aesthetic impacts will be temporary and could consist of the staging of construction equipment and materials.

---

# APPENDIX A

## PREFERRED ALTERNATIVE TYPICAL SECTION PACKAGE

STATE OF FLORIDA  
DEPARTMENT OF TRANSPORTATION

TYPICAL SECTION PACKAGE

FINANCIAL PROJECT ID 436928-2-32-01

LEE COUNTY (12630)

BURNT STORE ROAD

FROM VAN BUREN PARKWAY TO CHARLOTTE COUNTY LINE

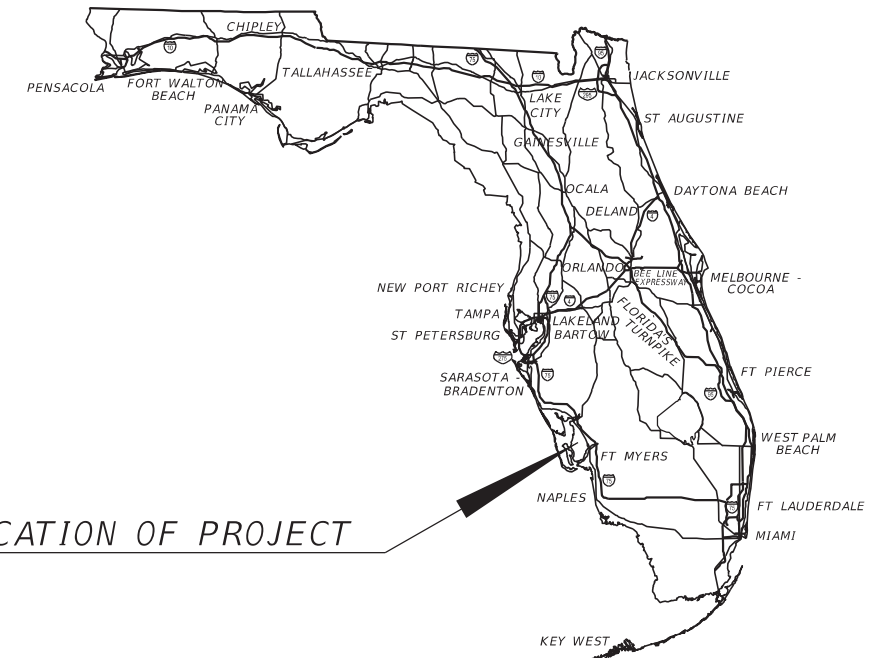

LOCATION OF PROJECT

FDOT DISTRICT DESIGN ENGINEER	FDOT DISTRICT TRAFFIC OPERATIONS ENGINEER
-------------------------------	---

CONCURRING WITH:  
TYPICAL SECTION ELEMENTS  
TARGET SPEED  
DESIGN & POSTED SPEEDS

CONCURRING WITH:  
TARGET SPEED  
DESIGN & POSTED SPEEDS

FDOT DISTRICT INTERMODAL SYSTEMS DEVELOPMENT MANAGER

FDOT DISTRICT STRUCTURES DESIGN ENGINEER

CONCURRING WITH:  
CONTEXT CLASSIFICATION  
TARGET SPEED

CONCURRING WITH:  
TYPICAL SECTION ELEMENTS  
TARGET SPEED

FHWA TRANSPORTATION ENGINEER

LOCAL TRANSPORTATION ENGINEER

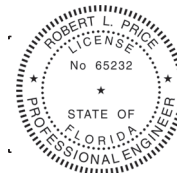

Digitally signed by  
Robert L. Price, P.E.  
65232 State of Florida  
Date: 2024.11.22  
12:42:01 -05'00'

CONCURRING WITH:  
TYPICAL SECTION ELEMENTS

CONCURRING WITH:  
TYPICAL SECTION ELEMENTS

NOT USED

NOT USED

CONCURRING WITH:

CONCURRING WITH:

PROJECT LOCATION URL:	<a href="https://tinyurl.com/xmdx943w">https://tinyurl.com/xmdx943w</a>
PROJECT LIMITS:	BEGIN MP 3.615 - END MP 9.148
EXCEPTIONS:	NONE
BRIDGE LIMITS:	MP 3.919 - MP 3.948 (BRIDGE #120025) MP 3.914 - MP 3.957 (BRIDGE #124140) MP 8.306 - MP 8.310 (BRIDGE #120054)
RAILROAD CROSSING:	NONE

APPROVED BY:

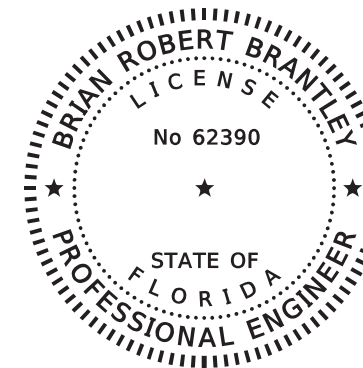

THIS ITEM HAS BEEN DIGITALLY SIGNED AND SEALED BY

**Brian R Brantley** 2024.11.20  
16:22:29-05'00'

ON THE DATE ADJACENT TO THE SEAL

PRINTED COPIES OF THIS DOCUMENT ARE NOT CONSIDERED SIGNED AND SEALED AND THE SIGNATURE MUST BE VERIFIED ON ANY ELECTRONIC COPIES.

BRIAN ROBERT BRANTLEY, P.E. NO.: 62390  
SCALAR CONSULTING GROUP INC.  
12620 TELECOM DRIVE  
TEMPLE TERRACE, FLORIDA 33637  
(813) 988-1199  
CONTRACT NO.: CA745  
VENDOR NO.: 451909667

THE ABOVE NAMED PROFESSIONAL ENGINEER SHALL BE RESPONSIBLE FOR THE FOLLOWING SHEETS IN ACCORDANCE WITH RULE 61G15-23.004, F.A.C.

INDEX OF SHEETS

SHEET NO	SHEET DESCRIPTION
1	COVER SHEET
2	TYPICAL SECTION NO. 1
3	TYPICAL SECTION NO. 2
4	TYPICAL SECTION NO. 3
5	TYPICAL SECTION NO. 4

**PROJECT CONTROLS**

**CONTEXT CLASSIFICATION**

- ( ) C1 : NATURAL ( ) C3C : SUBURBAN COMM.
- ( ) C2 : RURAL ( ) C4 : URBAN GENERAL
- ( ) C2T : RURAL TOWN ( ) C5 : URBAN CENTER
- (X) C3R : SUBURBAN RES. ( ) C6 : URBAN CORE
- ( ) N/A : L.A. FACILITY

**FUNCTIONAL CLASSIFICATION**

- ( ) INTERSTATE ( ) MAJOR COLLECTOR
- ( ) FREEWAY/EXPWY. ( ) MINOR COLLECTOR
- (X) PRINCIPAL ARTERIAL ( ) LOCAL
- ( ) MINOR ARTERIAL

**HIGHWAY SYSTEM**

- ( ) NATIONAL HIGHWAY SYSTEM
- ( ) STRATEGIC INTERMODAL SYSTEM
- ( ) STATE HIGHWAY SYSTEM
- (X) OFF-STATE HIGHWAY SYSTEM

**ACCESS CLASSIFICATION**

- ( ) 1 - FREEWAY
- ( ) 2 - RESTRICTIVE w/Service Roads
- (X) 3 - RESTRICTIVE w/660 ft. Connection Spacing
- ( ) 4 - NON-RESTRICTIVE w/2640 ft. Signal Spacing
- ( ) 5 - RESTRICTIVE w/440 ft. Connection Spacing
- ( ) 6 - NON-RESTRICTIVE w/1320 ft. Signal Spacing
- ( ) 7 - BOTH MEDIAN TYPES

**CRITERIA**

- (X) NEW CONSTRUCTION / RECONSTRUCTION
- ( ) RESURFACING (LA FACILITIES)
- ( ) RRR (ARTERIALS & COLLECTORS)

**POTENTIAL EXCEPTIONS AND VARIATIONS RELATED TO TYPICAL SECTION:**

DESIGN VARIATIONS:

- LANE WIDTH

**TYPICAL SECTION No. 01**

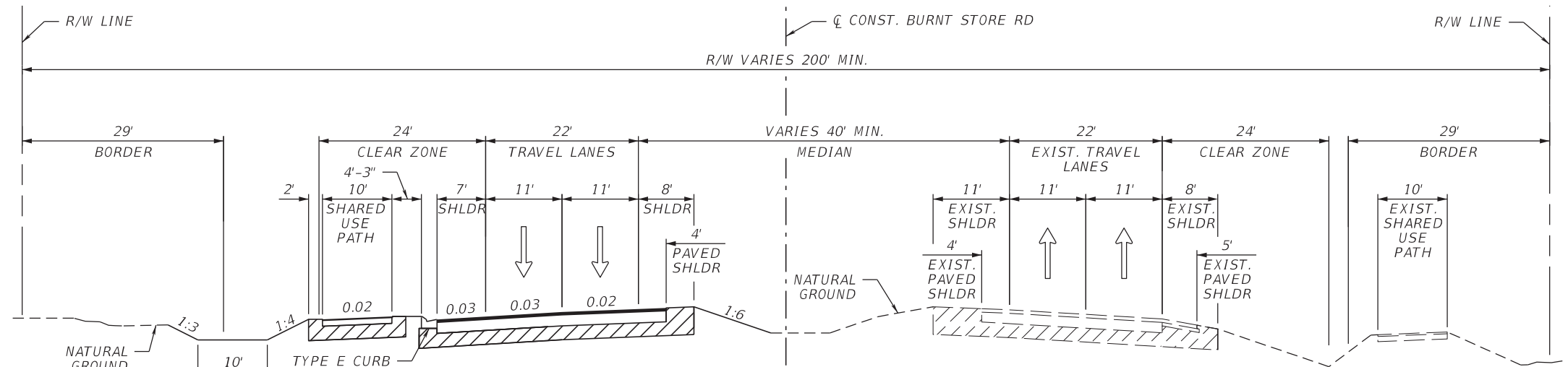

INTERIM

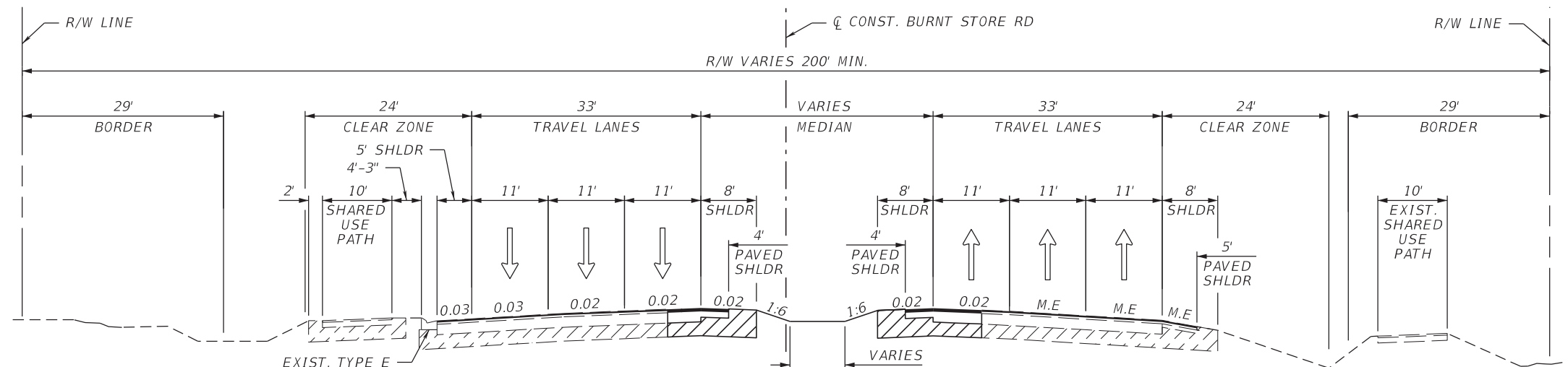

ULTIMATE (FUTURE TBD)

**TRAFFIC DATA**

CURRENT YEAR = 2024 AADT = 17400  
 ESTIMATED OPENING YEAR = 2028 AADT = 21900  
 ESTIMATED DESIGN YEAR = 2048 AADT = 44900  
 K = 9.5% D = 58% T = 11% (24 HOUR)  
 DESIGN HOUR T = 5.5%

INTERIM TARGET SPEED = 50 MPH  
 INTERIM DESIGN SPEED = 50 MPH  
 INTERIM POSTED SPEED = 50 MPH

ULTIMATE TARGET SPEED = 45 MPH  
 ULTIMATE DESIGN SPEED = 45 MPH  
 ULTIMATE POSTED SPEED = 45 MPH

TYPICAL SECTION #1  
 BURNT STORE RD  
 MP 3.615 TO MP 3.919

FINANCIAL PROJECT ID	SHEET NO.
436928-2-32-01	2

**PROJECT CONTROLS**

**CONTEXT CLASSIFICATION**

- ( ) C1 : NATURAL            ( ) C3C : SUBURBAN COMM.
- ( ) C2 : RURAL              ( ) C4 : URBAN GENERAL
- ( ) C2T : RURAL TOWN      ( ) C5 : URBAN CENTER
- (X) C3R : SUBURBAN RES.    ( ) C6 : URBAN CORE
- ( ) N/A : L.A. FACILITY

**FUNCTIONAL CLASSIFICATION**

- ( ) INTERSTATE            ( ) MAJOR COLLECTOR
- ( ) FREEWAY/EXPWY.      ( ) MINOR COLLECTOR
- (X) PRINCIPAL ARTERIAL    ( ) LOCAL
- ( ) MINOR ARTERIAL

**HIGHWAY SYSTEM**

- ( ) NATIONAL HIGHWAY SYSTEM
- ( ) STRATEGIC INTERMODAL SYSTEM
- ( ) STATE HIGHWAY SYSTEM
- (X) OFF-STATE HIGHWAY SYSTEM

**ACCESS CLASSIFICATION**

- ( ) 1 - FREEWAY
- ( ) 2 - RESTRICTIVE w/Service Roads
- (X) 3 - RESTRICTIVE w/660 ft. Connection Spacing
- ( ) 4 - NON-RESTRICTIVE w/2640 ft. Signal Spacing
- ( ) 5 - RESTRICTIVE w/440 ft. Connection Spacing
- ( ) 6 - NON-RESTRICTIVE w/1320 ft. Signal Spacing
- ( ) 7 - BOTH MEDIAN TYPES

**CRITERIA**

- (X) NEW CONSTRUCTION / RECONSTRUCTION
- ( ) RESURFACING (LA FACILITIES)
- ( ) RRR (ARTERIALS & COLLECTORS)

**POTENTIAL EXCEPTIONS AND VARIATIONS RELATED TO TYPICAL SECTION:**

DESIGN VARIATIONS:

- LANE WIDTH

**TYPICAL SECTION No. 02**

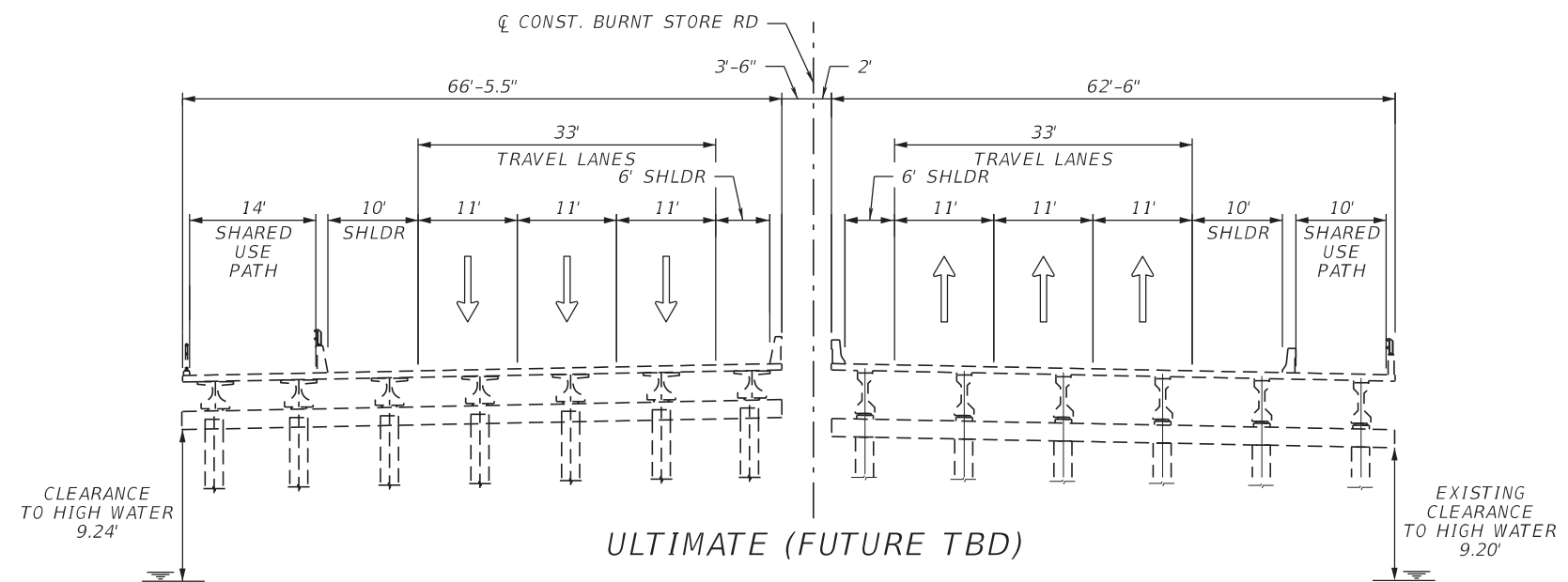
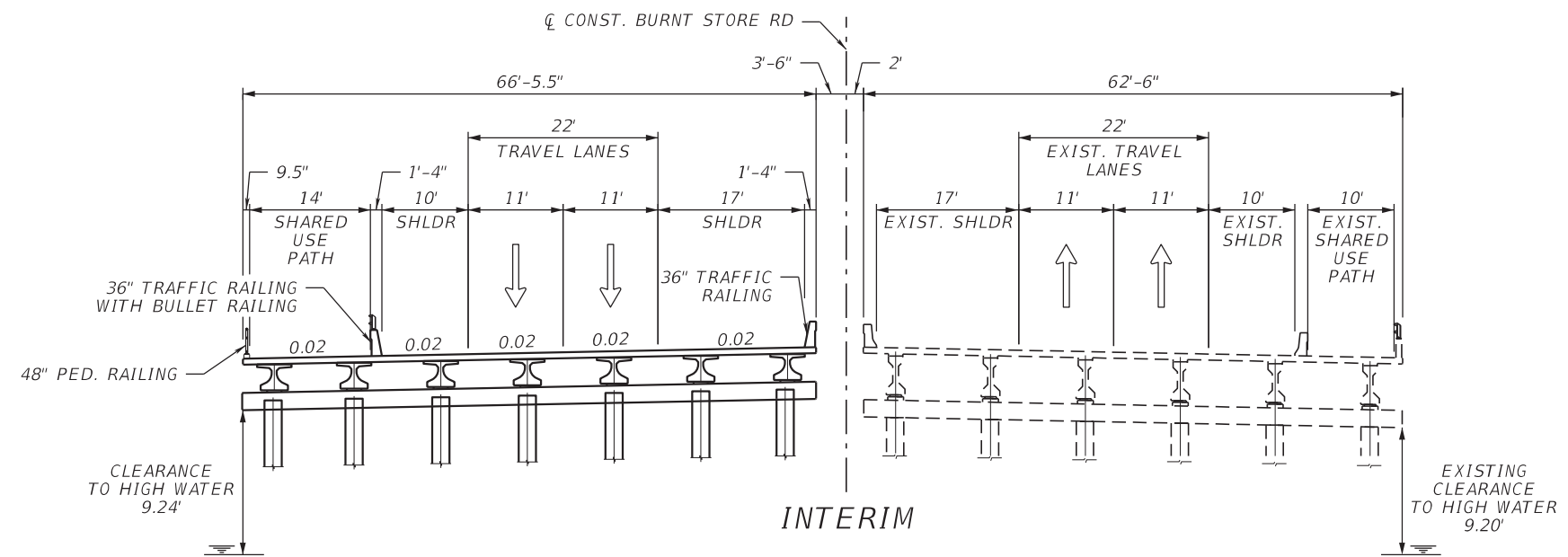

**TRAFFIC DATA**

CURRENT YEAR = 2024 AADT = 17400  
 ESTIMATED OPENING YEAR = 2028 AADT = 21900  
 ESTIMATED DESIGN YEAR = 2048 AADT = 44900  
 K = 9.5% D = 58% T = 11% (24 HOUR)  
 DESIGN HOUR T = 5.5%

INTERIM TARGET SPEED = 50 MPH  
 INTERIM DESIGN SPEED = 50 MPH  
 INTERIM POSTED SPEED = 50 MPH

ULTIMATE TARGET SPEED = 45 MPH  
 ULTIMATE DESIGN SPEED = 45 MPH  
 ULTIMATE POSTED SPEED = 45 MPH

**SOUTHBOUND BURNT STORE RD  
 BRIDGE NO. 120025 (PROPOSED)  
 MP 3.919 TO MP 3.948**

**NORTHBOUND BURNT STORE RD  
 BRIDGE NO. 124140 (EXISTING)  
 MP 3.914 TO MP 3.957**

**TYPICAL SECTION #2**

FINANCIAL PROJECT ID	SHEET NO.
436928-2-32-01	3

**PROJECT CONTROLS**

**CONTEXT CLASSIFICATION**

- ( ) C1 : NATURAL ( ) C3C : SUBURBAN COMM.
- ( ) C2 : RURAL ( ) C4 : URBAN GENERAL
- ( ) C2T : RURAL TOWN ( ) C5 : URBAN CENTER
- (X) C3R : SUBURBAN RES. ( ) C6 : URBAN CORE
- ( ) N/A : L.A. FACILITY

**FUNCTIONAL CLASSIFICATION**

- ( ) INTERSTATE ( ) MAJOR COLLECTOR
- ( ) FREEWAY/EXPWY. ( ) MINOR COLLECTOR
- (X) PRINCIPAL ARTERIAL ( ) LOCAL
- ( ) MINOR ARTERIAL

**HIGHWAY SYSTEM**

- ( ) NATIONAL HIGHWAY SYSTEM
- ( ) STRATEGIC INTERMODAL SYSTEM
- ( ) STATE HIGHWAY SYSTEM
- (X) OFF-STATE HIGHWAY SYSTEM

**ACCESS CLASSIFICATION**

- ( ) 1 - FREEWAY
- ( ) 2 - RESTRICTIVE w/Service Roads
- (X) 3 - RESTRICTIVE w/660 ft. Connection Spacing
- ( ) 4 - NON-RESTRICTIVE w/2640 ft. Signal Spacing
- ( ) 5 - RESTRICTIVE w/440 ft. Connection Spacing
- ( ) 6 - NON-RESTRICTIVE w/1320 ft. Signal Spacing
- ( ) 7 - BOTH MEDIAN TYPES

**CRITERIA**

- (X) NEW CONSTRUCTION / RECONSTRUCTION
- ( ) RESURFACING (LA FACILITIES)
- ( ) RRR (ARTERIALS & COLLECTORS)

**POTENTIAL EXCEPTIONS AND VARIATIONS RELATED TO TYPICAL SECTION:**

DESIGN VARIATIONS:  
- LANE WIDTH

**TYPICAL SECTION No. 03**

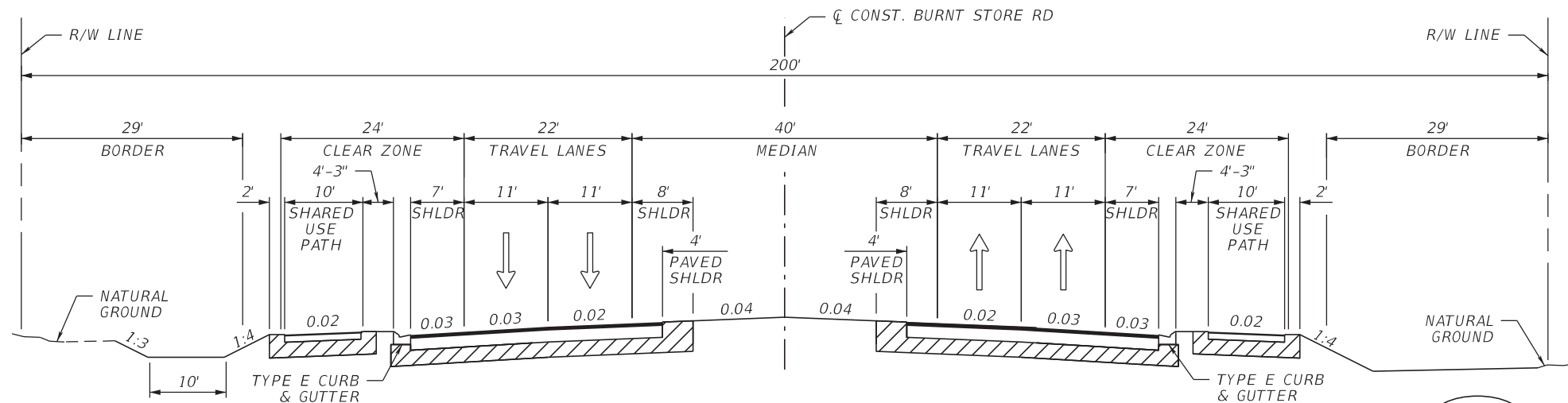

INTERIM

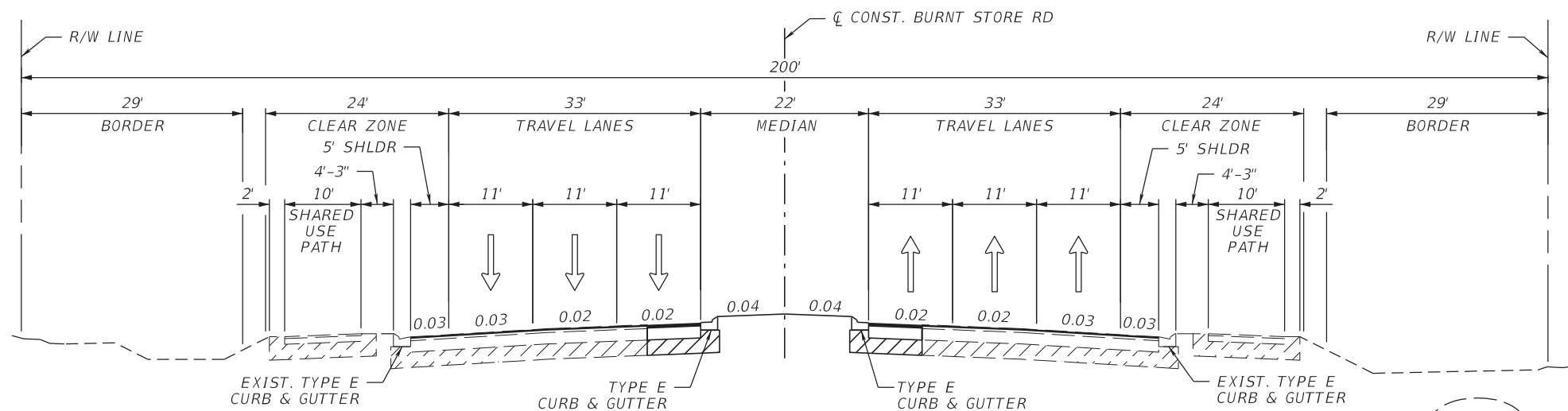

ULTIMATE (FUTURE TBD)

**TRAFFIC DATA**

CURRENT YEAR = 2024 AADT = 17400  
 ESTIMATED OPENING YEAR = 2028 AADT = 21900  
 ESTIMATED DESIGN YEAR = 2048 AADT = 44900  
 K = 9.5% D = 58% T = 11% (24 HOUR)  
 DESIGN HOUR T = 5.5%

INTERIM TARGET SPEED = 50 MPH  
 INTERIM DESIGN SPEED = 50 MPH  
 INTERIM POSTED SPEED = 50 MPH

ULTIMATE TARGET SPEED = 45 MPH  
 ULTIMATE DESIGN SPEED = 45 MPH  
 ULTIMATE POSTED SPEED = 45 MPH

**TYPICAL SECTION #3**

BURNT STORE RD  
 MP 3.948 TO MP 8.306  
 MP 8.310 TO MP 9.148

FINANCIAL PROJECT ID	SHEET NO.
436928-2-32-01	4

**PROJECT CONTROLS**

**CONTEXT CLASSIFICATION**

- ( ) C1 : NATURAL                      ( ) C3C : SUBURBAN COMM.
- ( ) C2 : RURAL                        ( ) C4 : URBAN GENERAL
- ( ) C2T : RURAL TOWN                ( ) C5 : URBAN CENTER
- (X) C3R : SUBURBAN RES.            ( ) C6 : URBAN CORE
- ( ) N/A : L.A. FACILITY

**FUNCTIONAL CLASSIFICATION**

- ( ) INTERSTATE                        ( ) MAJOR COLLECTOR
- ( ) FREEWAY/EXPWY.                ( ) MINOR COLLECTOR
- (X) PRINCIPAL ARTERIAL            ( ) LOCAL
- ( ) MINOR ARTERIAL

**HIGHWAY SYSTEM**

- ( ) NATIONAL HIGHWAY SYSTEM
- ( ) STRATEGIC INTERMODAL SYSTEM
- ( ) STATE HIGHWAY SYSTEM
- (X) OFF-STATE HIGHWAY SYSTEM

**ACCESS CLASSIFICATION**

- ( ) 1 - FREEWAY
- ( ) 2 - RESTRICTIVE w/Service Roads
- (X) 3 - RESTRICTIVE w/660 ft. Connection Spacing
- ( ) 4 - NON-RESTRICTIVE w/2640 ft. Signal Spacing
- ( ) 5 - RESTRICTIVE w/440 ft. Connection Spacing
- ( ) 6 - NON-RESTRICTIVE w/1320 ft. Signal Spacing
- ( ) 7 - BOTH MEDIAN TYPES

**CRITERIA**

- (X) NEW CONSTRUCTION / RECONSTRUCTION
- ( ) RESURFACING (LA FACILITIES)
- ( ) RRR (ARTERIALS & COLLECTORS)

**POTENTIAL EXCEPTIONS AND VARIATIONS RELATED TO TYPICAL SECTION:**

DESIGN VARIATIONS:

- LANE WIDTH

**TYPICAL SECTION No. 04**

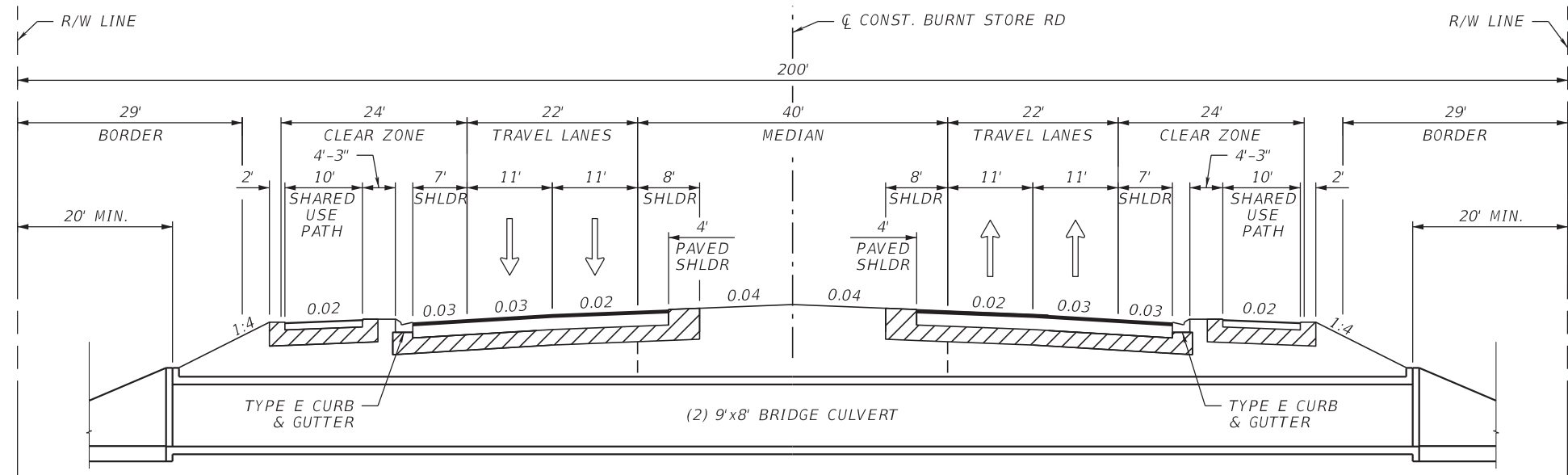

**INTERIM**

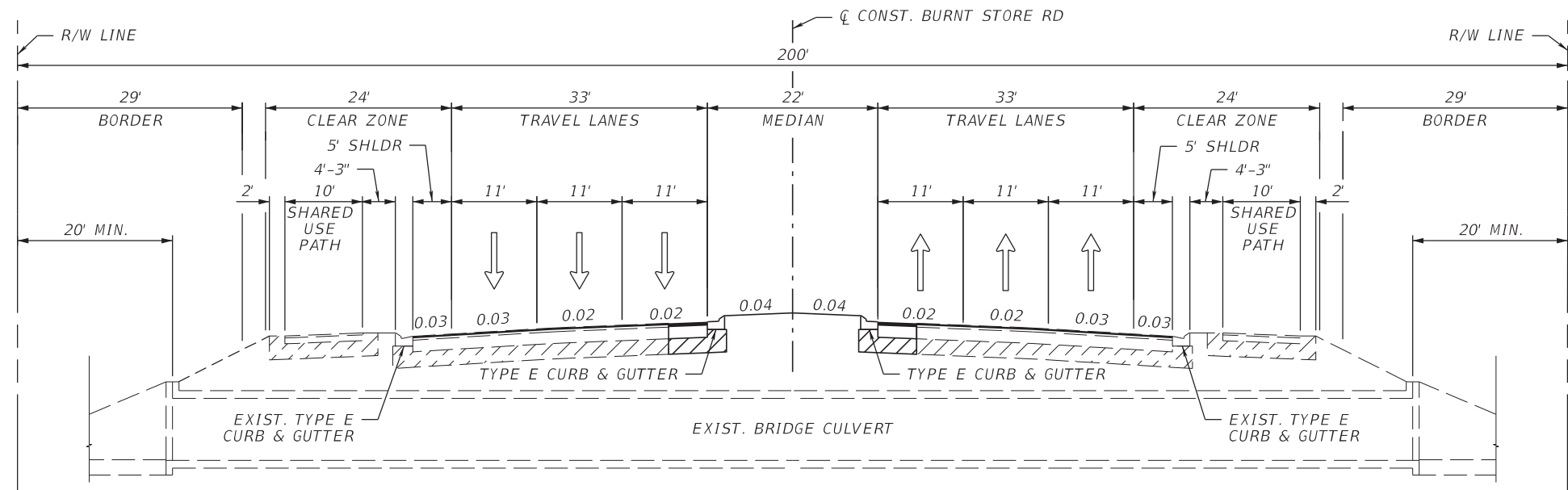

**ULTIMATE (FUTURE TBD)**

**TRAFFIC DATA**

CURRENT YEAR = 2024 AADT = 17400  
 ESTIMATED OPENING YEAR = 2028 AADT = 21900  
 ESTIMATED DESIGN YEAR = 2048 AADT = 44900  
 K = 9.5% D = 58% T = 11% (24 HOUR)  
 DESIGN HOUR T = 5.5%

INTERIM TARGET SPEED = 50 MPH  
 INTERIM DESIGN SPEED = 50 MPH  
 INTERIM POSTED SPEED = 50 MPH

ULTIMATE TARGET SPEED = 45 MPH  
 ULTIMATE DESIGN SPEED = 45 MPH  
 ULTIMATE POSTED SPEED = 45 MPH

**TYPICAL SECTION #4**

**BURNT STORE RD  
 BRIDGE NO. 120054  
 MP 8.306 TO MP 8.310**

FINANCIAL PROJECT ID	SHEET NO.
436928-2-32-01	5



---

# APPENDIX B

## PREFERRED ALTERNATIVE CONCEPTUAL PLANS

11:45:08 AM kamaya  
P:\2019\SP19D1000 Burnt Store Rd. PD&E\43692812201\roadway\PLAWR001.dgn

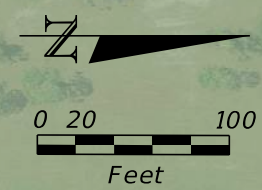
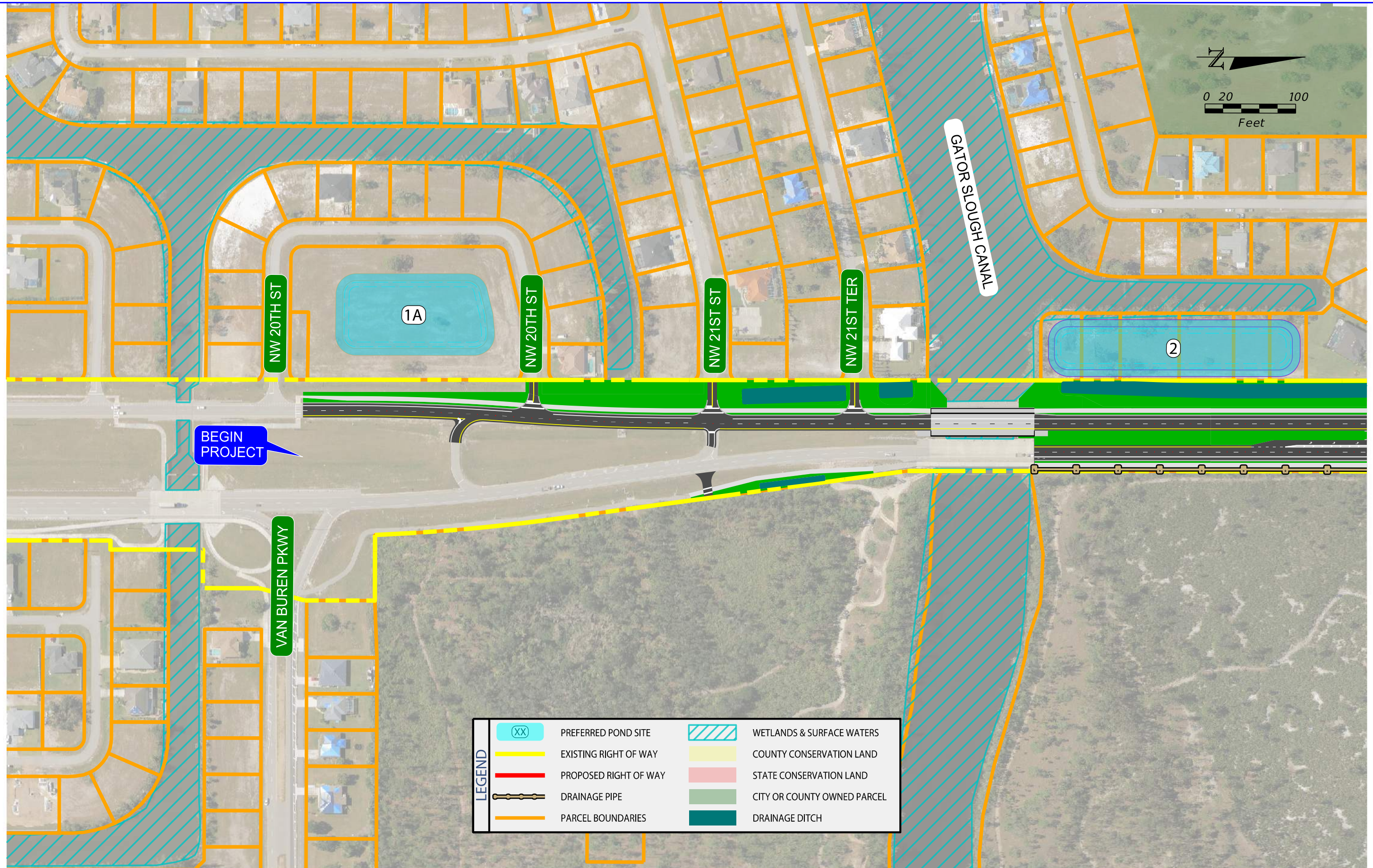

LEGEND	
(XX)	PREFERRED POND SITE
—	EXISTING RIGHT OF WAY
—	PROPOSED RIGHT OF WAY
—	DRAINAGE PIPE
—	PARCEL BOUNDARIES
▨	WETLANDS & SURFACE WATERS
▨	COUNTY CONSERVATION LAND
▨	STATE CONSERVATION LAND
▨	CITY OR COUNTY OWNED PARCEL
▨	DRAINAGE DITCH

REVISIONS		ENGINEER OF RECORD		STATE OF FLORIDA DEPARTMENT OF TRANSPORTATION			URBAN ALTERNATIVE WITH DITCH	SHEET NO.  1
DATE	DESCRIPTION	DATE	DESCRIPTION	ROAD NO.	COUNTY	FINANCIAL PROJECT ID		
				CR 765	LEE	436928-1-22-01		

ANIRUDDHA S. GOTMARE, P.E.  
P.E. LICENSE NUMBER 54801  
SCALAR CONSULTING GROUP INC.  
5713 CORPORATE WAY  
WEST PALM BEACH, FL 33407

THE OFFICIAL RECORD OF THIS SHEET IS THE ELECTRONIC FILE DIGITALLY SIGNED AND SEALED UNDER RULE 61G15-23.004, F.A.C.

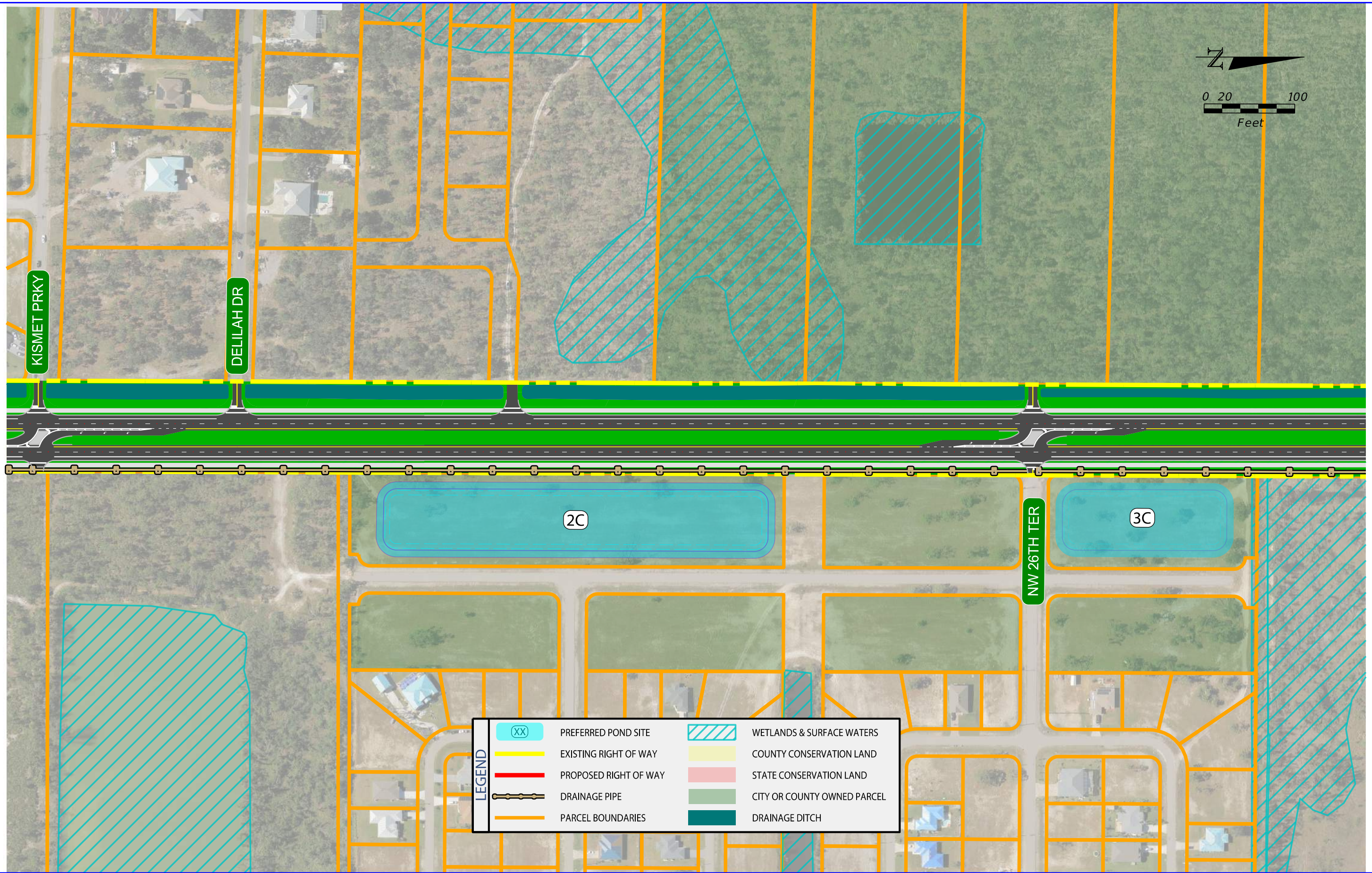
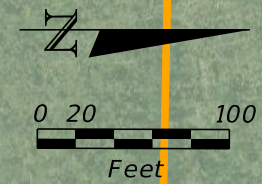

LEGEND	
	PREFERRED POND SITE
	EXISTING RIGHT OF WAY
	PROPOSED RIGHT OF WAY
	DRAINAGE PIPE
	PARCEL BOUNDARIES
	WETLANDS & SURFACE WATERS
	COUNTY CONSERVATION LAND
	STATE CONSERVATION LAND
	CITY OR COUNTY OWNED PARCEL
	DRAINAGE DITCH

12/24/2024 11:45:15 AM kamaya  
 P:\2019\SP19D1000 Burnt Store Rd. PD&E\43692812201\roadway\PLAMRD01.dgn

THE OFFICIAL RECORD OF THIS SHEET IS THE ELECTRONIC FILE DIGITALLY SIGNED AND SEALED UNDER RULE 61G15-23.004, F.A.C.

REVISIONS				ENGINEER OF RECORD		STATE OF FLORIDA DEPARTMENT OF TRANSPORTATION			URBAN ALTERNATIVE WITH DITCH	SHEET NO.  2
DATE	DESCRIPTION	DATE	DESCRIPTION			ROAD NO.	COUNTY	FINANCIAL PROJECT ID		
				ANIRUDDHA S. GOTMARE, P.E. P.E. LICENSE NUMBER 54801 SCALAR CONSULTING GROUP INC. 5713 CORPORATE WAY WEST PALM BEACH, FL 33407		CR 765	LEE	436928-1-22-01		

12/24/2024 11:45:27 AM kamaya  
P:\2019\SP19D1000 Burnt Store Rd. PD&E\43692812201\roadway\PLAMRD01.dgn

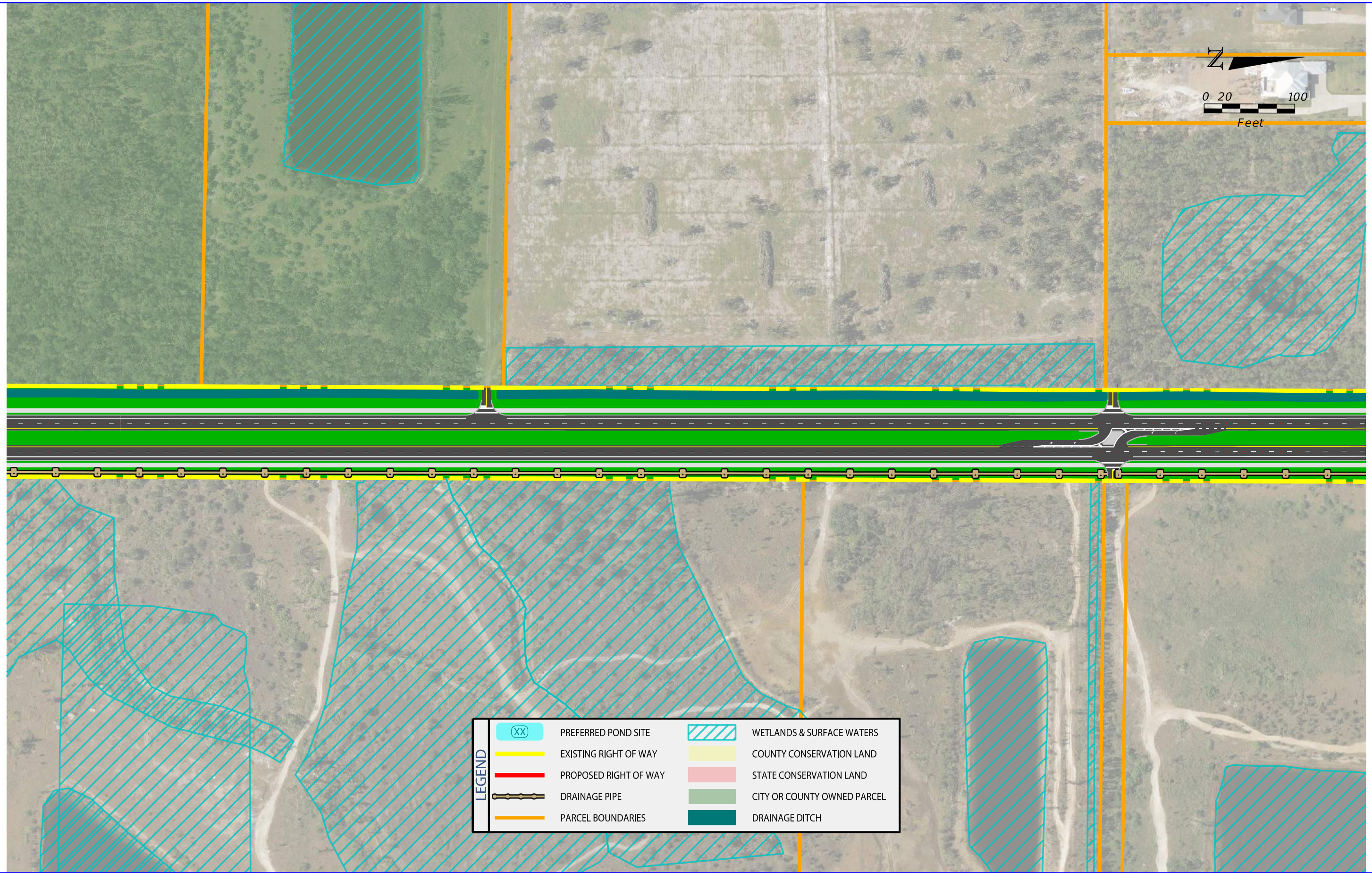

LEGEND	
	PREFERRED POND SITE
	EXISTING RIGHT OF WAY
	PROPOSED RIGHT OF WAY
	DRAINAGE PIPE
	PARCEL BOUNDARIES
	WETLANDS & SURFACE WATERS
	COUNTY CONSERVATION LAND
	STATE CONSERVATION LAND
	CITY OR COUNTY OWNED PARCEL
	DRAINAGE DITCH

REVISIONS			
DATE	DESCRIPTION	DATE	DESCRIPTION

ENGINEER OF RECORD  
ANIRUDDHA S. GOTMARE, P.E.  
P.E. LICENSE NUMBER 54801  
SCALAR CONSULTING GROUP INC.  
5713 CORPORATE WAY  
WEST PALM BEACH, FL 33407

STATE OF FLORIDA DEPARTMENT OF TRANSPORTATION		
ROAD NO.	COUNTY	FINANCIAL PROJECT ID
CR 765	LEE	436928-1-22-01

**URBAN ALTERNATIVE  
WITH DITCH**

SHEET NO.  
3

THE OFFICIAL RECORD OF THIS SHEET IS THE ELECTRONIC FILE DIGITALLY SIGNED AND SEALED UNDER RULE 61G15-23.004, F.A.C.

12/24/2024 11:45:32 AM kamaya  
P:\2019\SP19D1000 Burnt Store Rd. PD&E\43692812201\roadway\PLAMRD01.dgn

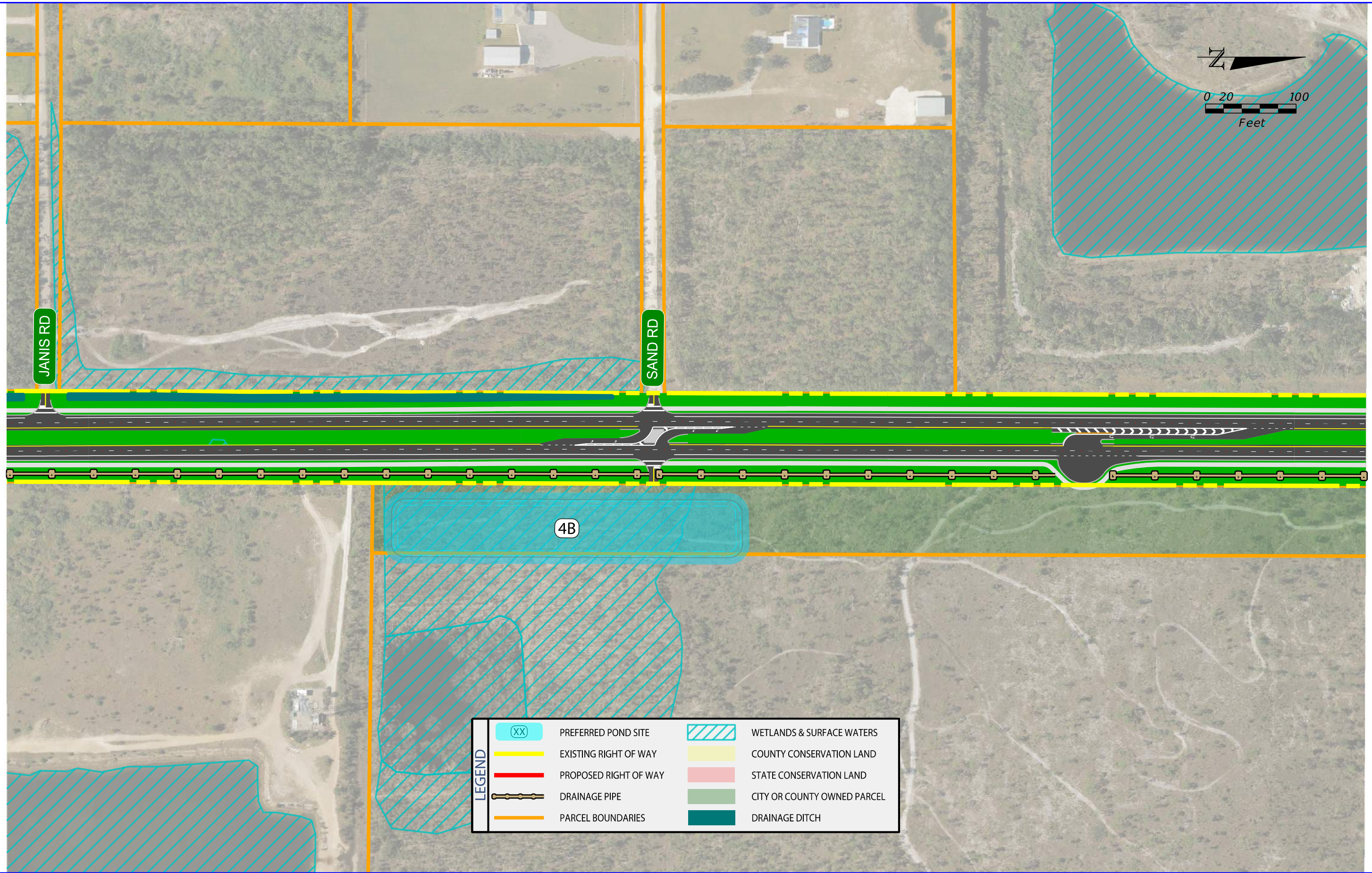

LEGEND	
(XX)	PREFERRED POND SITE
Yellow line	EXISTING RIGHT OF WAY
Red line	PROPOSED RIGHT OF WAY
Black line with circles	DRAINAGE PIPE
Orange line	PARCEL BOUNDARIES
Blue hatched area	WETLANDS & SURFACE WATERS
Light yellow area	COUNTY CONSERVATION LAND
Pink area	STATE CONSERVATION LAND
Green area	CITY OR COUNTY OWNED PARCEL
Dark green area	DRAINAGE DITCH

REVISIONS			
DATE	DESCRIPTION	DATE	DESCRIPTION

ENGINEER OF RECORD  
ANIRUDDHA S. GOTMARE, P.E.  
P.E. LICENSE NUMBER 54801  
SCALAR CONSULTING GROUP INC.  
5713 CORPORATE WAY  
WEST PALM BEACH, FL 33407

STATE OF FLORIDA DEPARTMENT OF TRANSPORTATION		
ROAD NO.	COUNTY	FINANCIAL PROJECT ID
CR 765	LEE	436928-1-22-01

**URBAN ALTERNATIVE  
WITH DITCH**

SHEET NO.  
**4**

THE OFFICIAL RECORD OF THIS SHEET IS THE ELECTRONIC FILE DIGITALLY SIGNED AND SEALED UNDER RULE 61G15-23.004, F.A.C.

12/24/2024 11:45:40 AM kamaya  
P:\2019\SP19D1000 Burnt Store Rd. PD&E\43692812201\roadway\PLAWR001.dgn

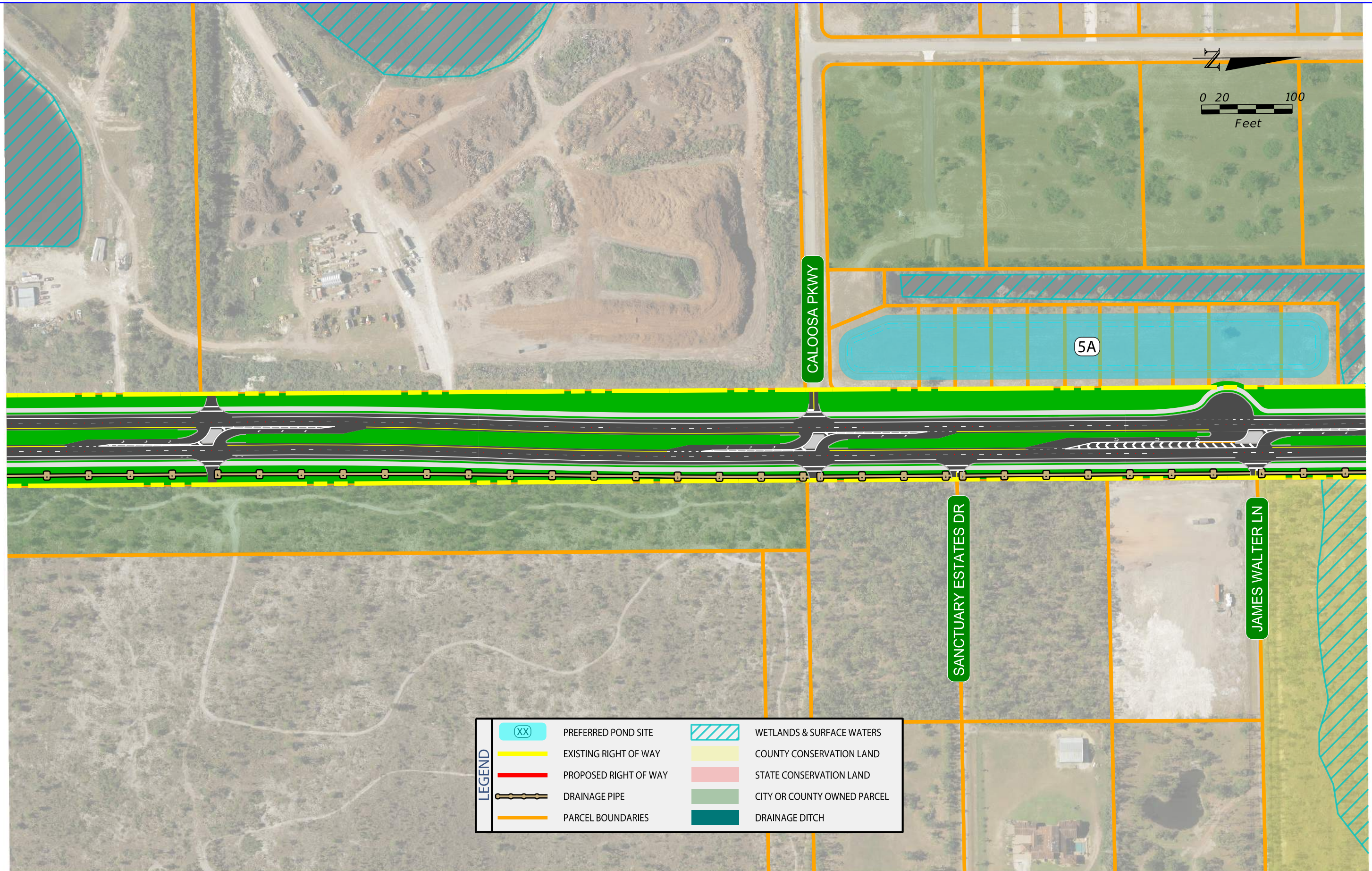

LEGEND			
(XX)	PREFERRED POND SITE		WETLANDS & SURFACE WATERS
	EXISTING RIGHT OF WAY		COUNTY CONSERVATION LAND
	PROPOSED RIGHT OF WAY		STATE CONSERVATION LAND
	DRAINAGE PIPE		CITY OR COUNTY OWNED PARCEL
	PARCEL BOUNDARIES		DRAINAGE DITCH

REVISIONS			
DATE	DESCRIPTION	DATE	DESCRIPTION

ENGINEER OF RECORD  
ANIRUDDHA S. GOTMARE, P.E.  
P.E. LICENSE NUMBER 54801  
SCALAR CONSULTING GROUP INC.  
5713 CORPORATE WAY  
WEST PALM BEACH, FL 33407

STATE OF FLORIDA DEPARTMENT OF TRANSPORTATION		
ROAD NO.	COUNTY	FINANCIAL PROJECT ID
CR 765	LEE	436928-1-22-01

**URBAN ALTERNATIVE  
WITH DITCH**

SHEET NO.  
5

THE OFFICIAL RECORD OF THIS SHEET IS THE ELECTRONIC FILE DIGITALLY SIGNED AND SEALED UNDER RULE 61G15-23.004, F.A.C.

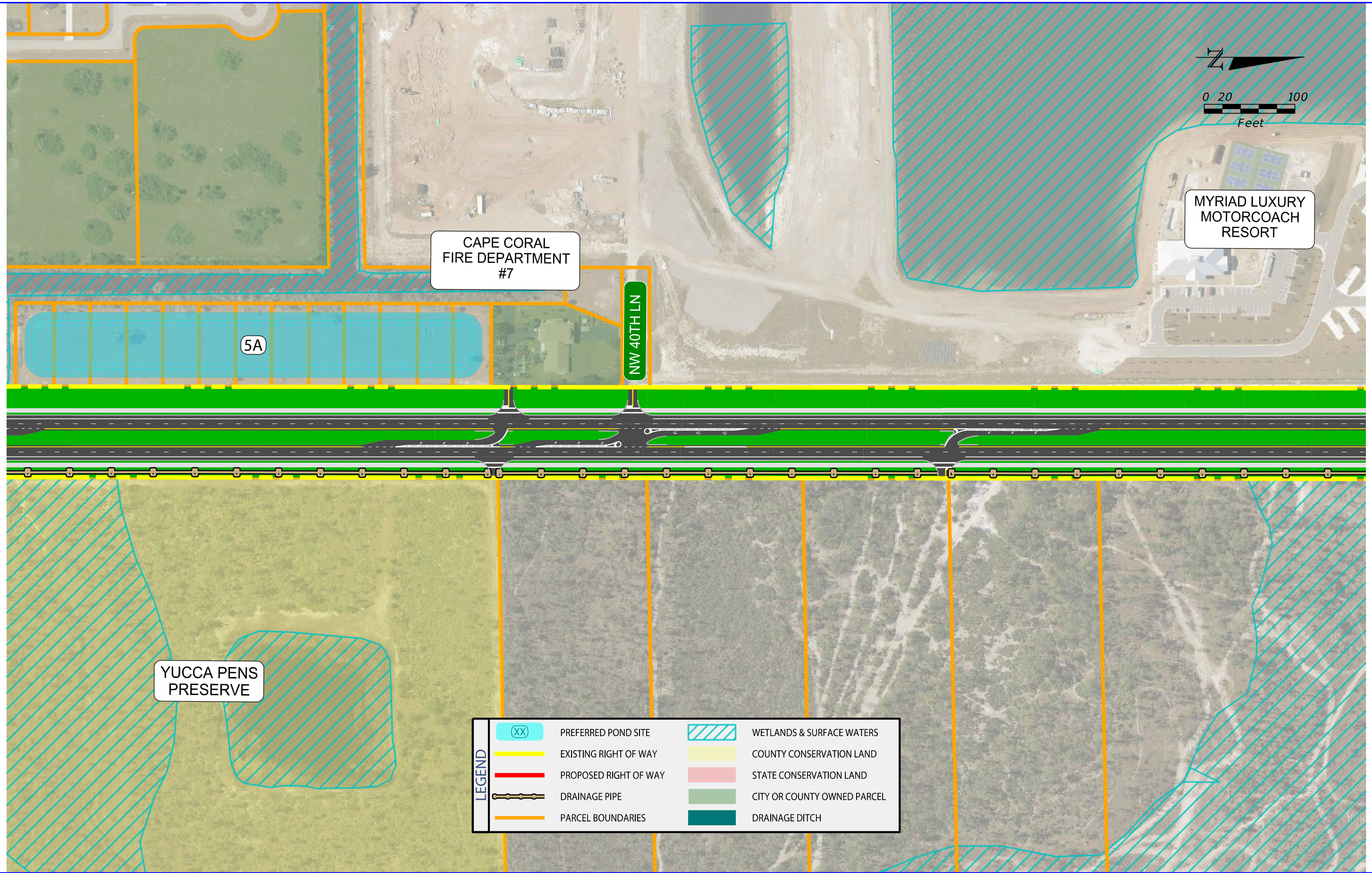

12/24/2024 11:45:50 AM kamaya  
 P:\2019\SP19D1000 Burnt Store Rd. PD&E\43692812201\roadway\PLAWR001.dgn

THE OFFICIAL RECORD OF THIS SHEET IS THE ELECTRONIC FILE DIGITALLY SIGNED AND SEALED UNDER RULE 61G15-23.004, F.A.C.

REVISIONS				ENGINEER OF RECORD		STATE OF FLORIDA DEPARTMENT OF TRANSPORTATION			URBAN ALTERNATIVE WITH DITCH	SHEET NO.  6
DATE	DESCRIPTION	DATE	DESCRIPTION			ROAD NO.	COUNTY	FINANCIAL PROJECT ID		
				ANIRUDDHA S. GOTMARE, P.E. P.E. LICENSE NUMBER 54801 SCALAR CONSULTING GROUP INC. 5713 CORPORATE WAY WEST PALM BEACH, FL 33407		CR 765	LEE	436928-1-22-01		

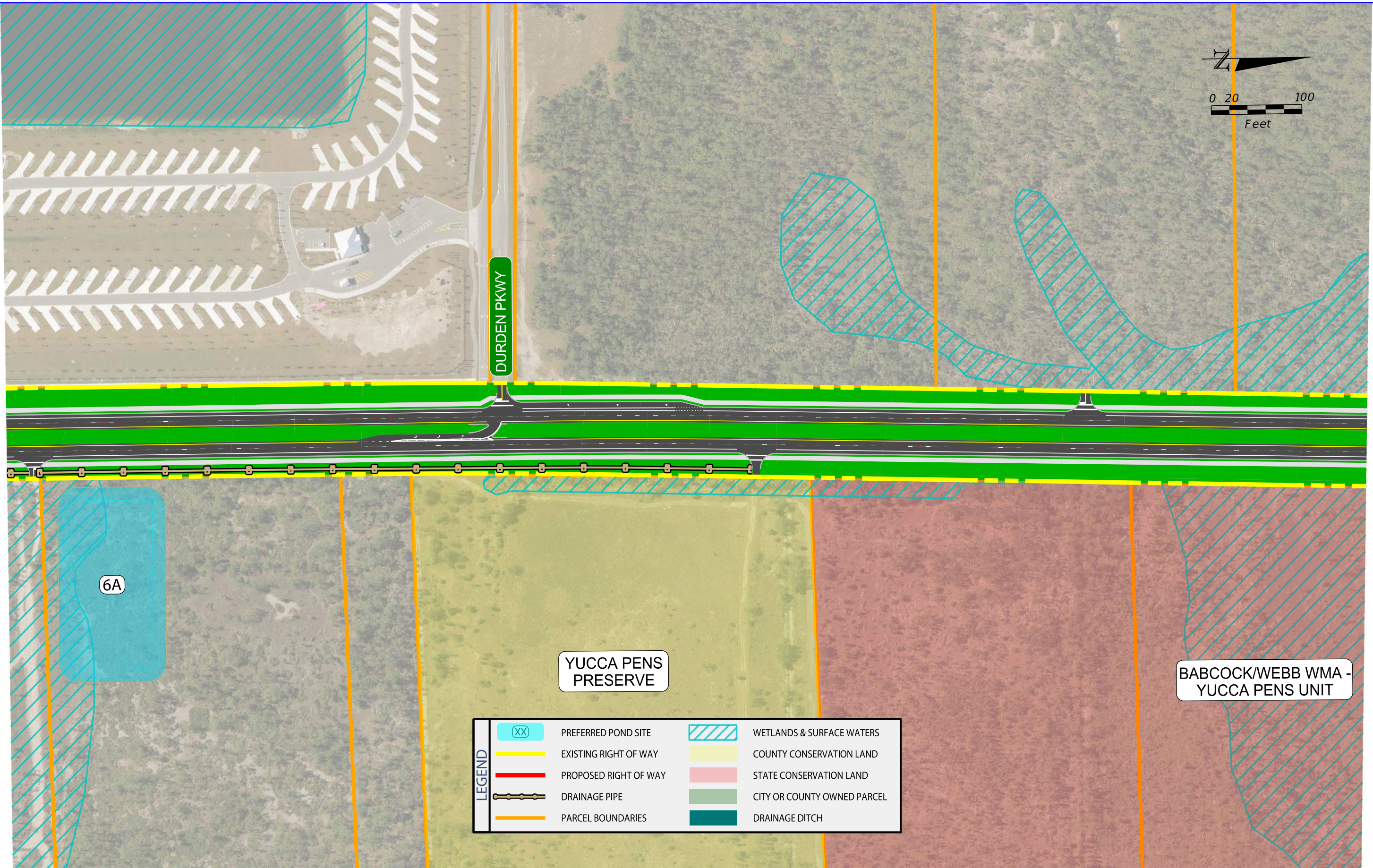

LEGEND	
	PREFERRED POND SITE
	EXISTING RIGHT OF WAY
	PROPOSED RIGHT OF WAY
	DRAINAGE PIPE
	PARCEL BOUNDARIES
	WETLANDS & SURFACE WATERS
	COUNTY CONSERVATION LAND
	STATE CONSERVATION LAND
	CITY OR COUNTY OWNED PARCEL
	DRAINAGE DITCH

12/24/2024 11:45:56 AM kamaya P:\2019\SP19D1000 Burnt Store Rd. PD&E\43692812201\roadway\PLAMRD01.dgn

THE OFFICIAL RECORD OF THIS SHEET IS THE ELECTRONIC FILE DIGITALLY SIGNED AND SEALED UNDER RULE 61G15-23.004, F.A.C.

REVISIONS				ENGINEER OF RECORD		STATE OF FLORIDA DEPARTMENT OF TRANSPORTATION			URBAN ALTERNATIVE WITH DITCH	SHEET NO.  7
DATE	DESCRIPTION	DATE	DESCRIPTION			ROAD NO.	COUNTY	FINANCIAL PROJECT ID		
				ANIRUDDHA S. GOTMARE, P.E. P.E. LICENSE NUMBER 54801 SCALAR CONSULTING GROUP INC. 5713 CORPORATE WAY WEST PALM BEACH, FL 33407		CR 765	LEE	436928-1-22-01		



12/24/2024 11:46:08 AM kamaya  
P:\2019\SP19D1000 Burnt Store Rd. PD&E\43692812201\roadway\PLAWR001.dgn

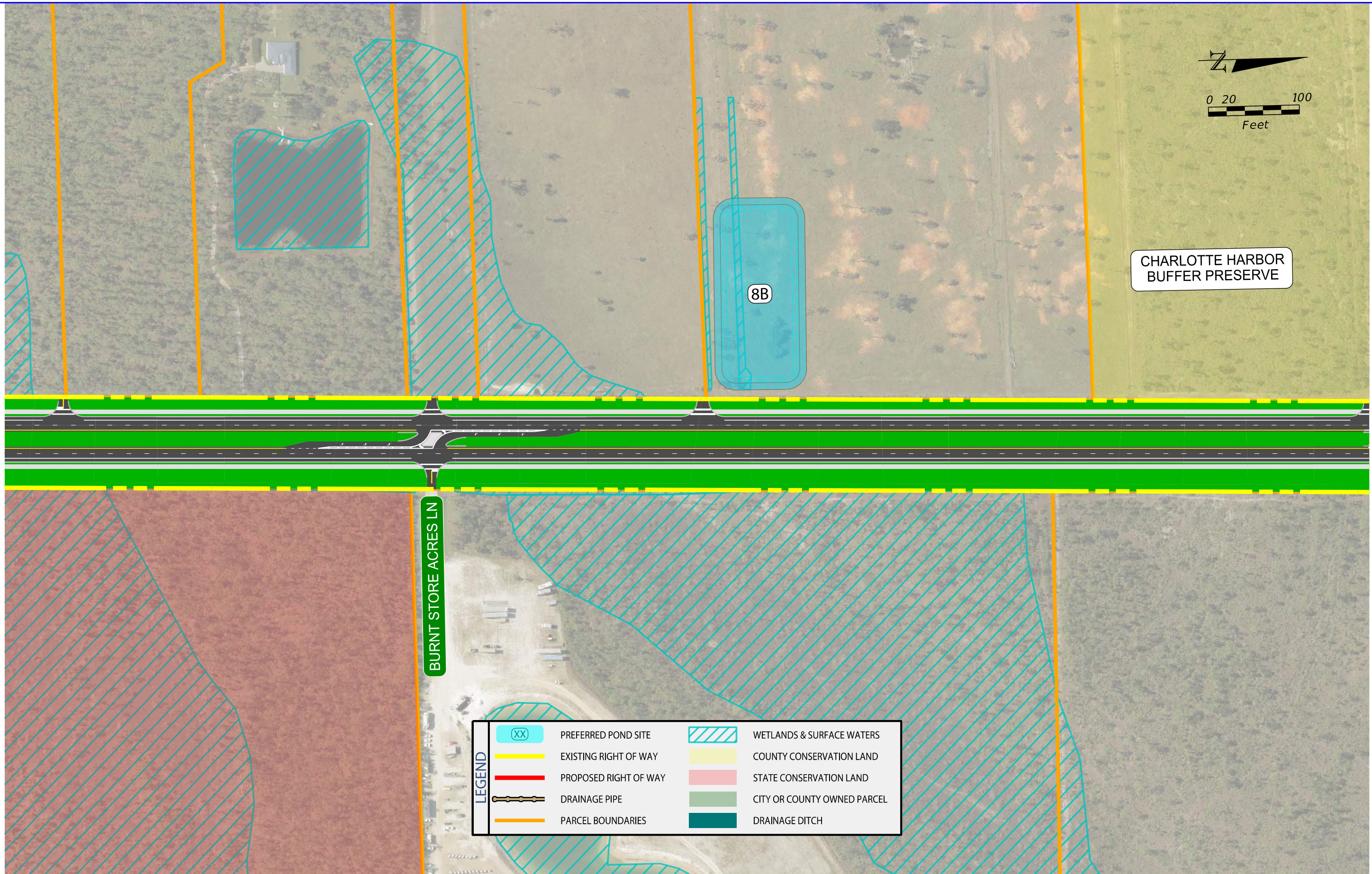

BURNT STORE ACRES LN

LEGEND	
(XX)	PREFERRED POND SITE
Yellow dashed line	EXISTING RIGHT OF WAY
Red dashed line	PROPOSED RIGHT OF WAY
Black line with circles	DRAINAGE PIPE
Orange line	PARCEL BOUNDARIES
Blue hatched area	WETLANDS & SURFACE WATERS
Light yellow area	COUNTY CONSERVATION LAND
Light red area	STATE CONSERVATION LAND
Green area	CITY OR COUNTY OWNED PARCEL
Dark green area	DRAINAGE DITCH

REVISIONS				ENGINEER OF RECORD		STATE OF FLORIDA DEPARTMENT OF TRANSPORTATION			URBAN ALTERNATIVE WITH DITCH	SHEET NO.  8
DATE	DESCRIPTION	DATE	DESCRIPTION			ROAD NO.	COUNTY	FINANCIAL PROJECT ID		
				ANIRUDDHA S. GOTMARE, P.E. P.E. LICENSE NUMBER 54801 SCALAR CONSULTING GROUP INC. 5713 CORPORATE WAY WEST PALM BEACH, FL 33407		CR 765	LEE	436928-1-22-01		

THE OFFICIAL RECORD OF THIS SHEET IS THE ELECTRONIC FILE DIGITALLY SIGNED AND SEALED UNDER RULE 61G15-23.004, F.A.C.

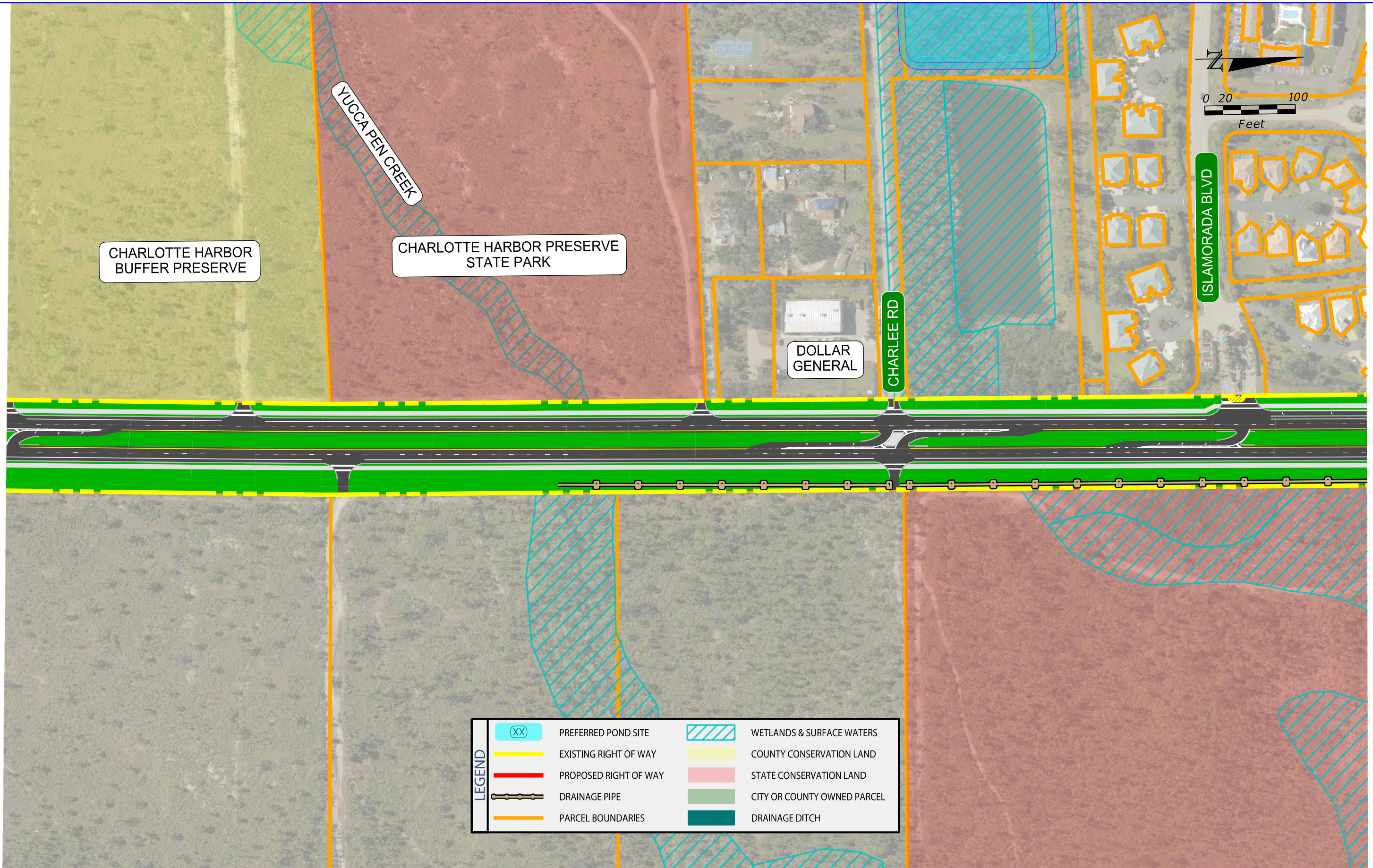

12/24/2024 11:46:13 AM kamaya  
 P:\2019\SP19D1000 Burnt Store Rd. PD&E\43692812201\roadway\PLAMRD01.dgn

THE OFFICIAL RECORD OF THIS SHEET IS THE ELECTRONIC FILE DIGITALLY SIGNED AND SEALED UNDER RULE 61G15-23.004, F.A.C.

REVISIONS				ENGINEER OF RECORD		STATE OF FLORIDA DEPARTMENT OF TRANSPORTATION			URBAN ALTERNATIVE WITH DITCH	SHEET NO.  9
DATE	DESCRIPTION	DATE	DESCRIPTION			ROAD NO.	COUNTY	FINANCIAL PROJECT ID		
				ANIRUDDHA S. GOTMARE, P.E. P.E. LICENSE NUMBER 54801 SCALAR CONSULTING GROUP INC. 5713 CORPORATE WAY WEST PALM BEACH, FL 33407		CR 765	LEE	436928-1-22-01		

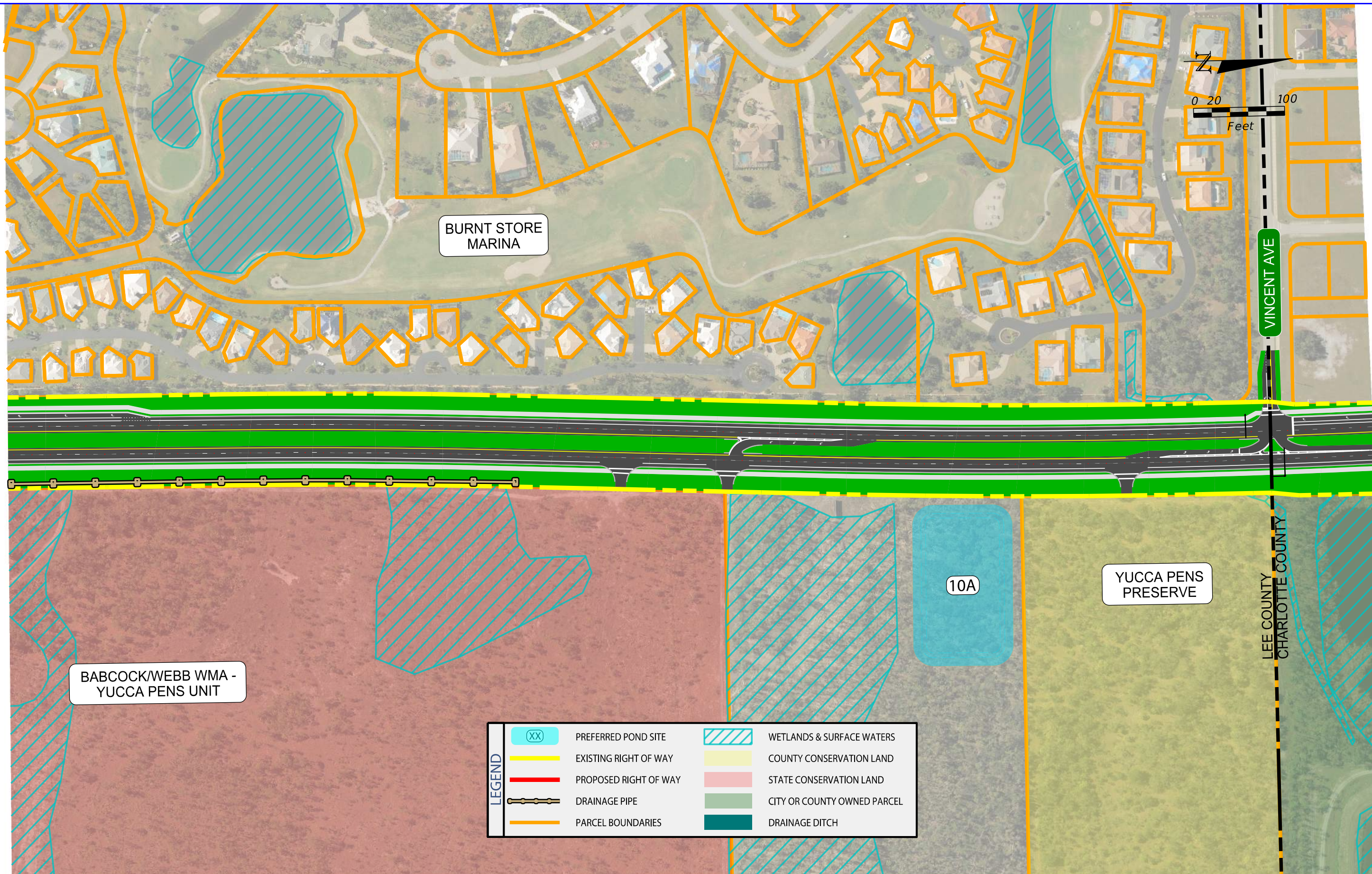

12/24/2024 11:46:22 AM kamaya  
 P:\2019\SP19D1000 Burnt Store Rd. PD&E\43692812201\roadway\PLAMRD01.dgn

THE OFFICIAL RECORD OF THIS SHEET IS THE ELECTRONIC FILE DIGITALLY SIGNED AND SEALED UNDER RULE 61G15-23.004, F.A.C.

REVISIONS				ENGINEER OF RECORD		STATE OF FLORIDA DEPARTMENT OF TRANSPORTATION			URBAN ALTERNATIVE WITH DITCH	SHEET NO.  10
DATE	DESCRIPTION	DATE	DESCRIPTION			ROAD NO.	COUNTY	FINANCIAL PROJECT ID		
				ANIRUDDHA S. GOTMARE, P.E. P.E. LICENSE NUMBER 54801 SCALAR CONSULTING GROUP INC. 5713 CORPORATE WAY WEST PALM BEACH, FL 33407		CR 765	LEE	436928-1-22-01		

12/24/2024 11:46:31 AM kamaya  
P:\2019\SP19D1000 Burnt Store Rd. PD&E\43692812201\roadway\PLAMRD01.dgn

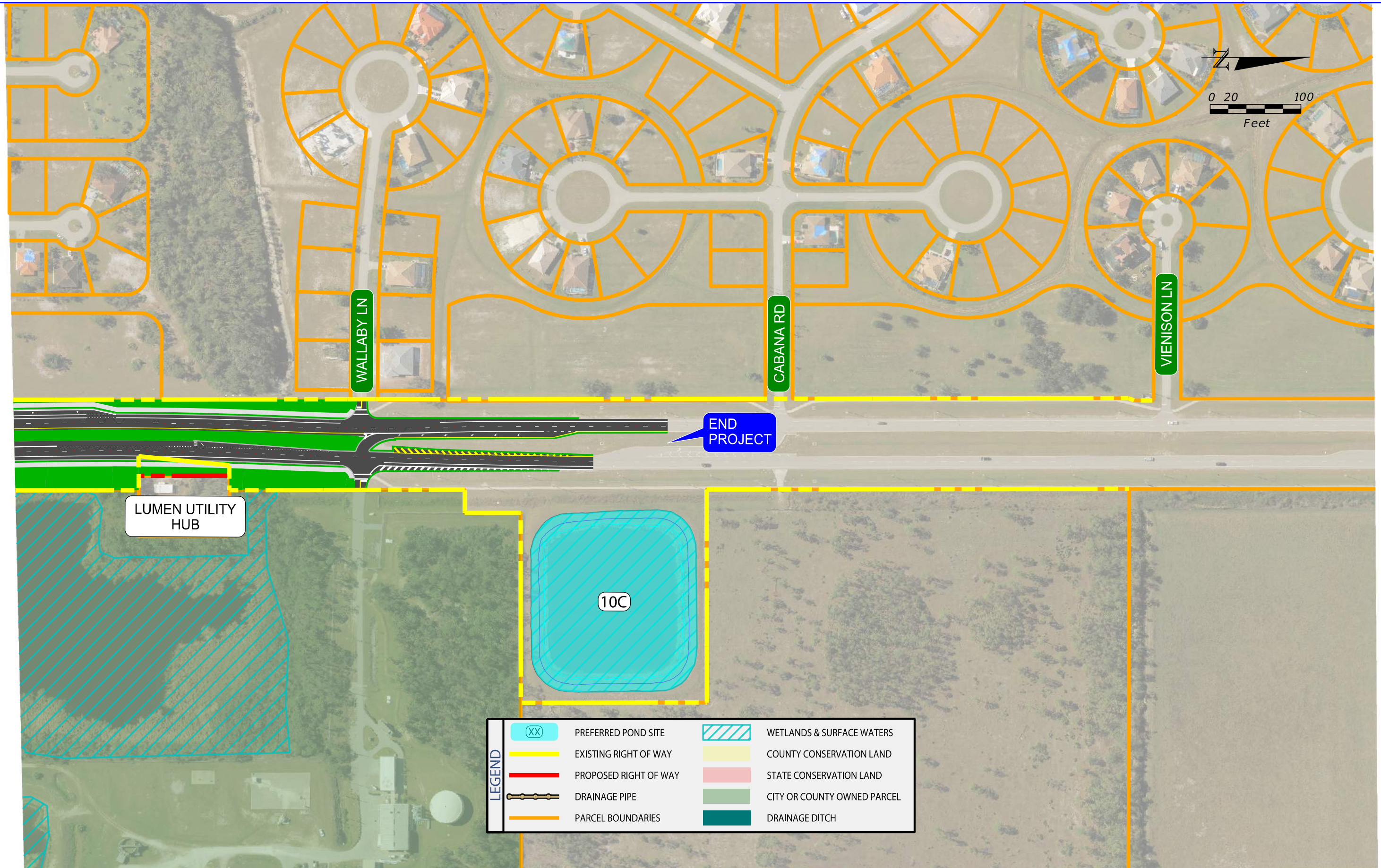

LEGEND	
	PREFERRED POND SITE
	EXISTING RIGHT OF WAY
	PROPOSED RIGHT OF WAY
	DRAINAGE PIPE
	PARCEL BOUNDARIES
	WETLANDS & SURFACE WATERS
	COUNTY CONSERVATION LAND
	STATE CONSERVATION LAND
	CITY OR COUNTY OWNED PARCEL
	DRAINAGE DITCH

REVISIONS			
DATE	DESCRIPTION	DATE	DESCRIPTION

ENGINEER OF RECORD  
ANIRUDDHA S. GOTMARE, P.E.  
P.E. LICENSE NUMBER 54801  
SCALAR CONSULTING GROUP INC.  
5713 CORPORATE WAY  
WEST PALM BEACH, FL 33407

STATE OF FLORIDA DEPARTMENT OF TRANSPORTATION		
ROAD NO.	COUNTY	FINANCIAL PROJECT ID
CR 765	LEE	436928-1-22-01

**URBAN ALTERNATIVE  
WITH DITCH**

SHEET NO.  
**11**

THE OFFICIAL RECORD OF THIS SHEET IS THE ELECTRONIC FILE DIGITALLY SIGNED AND SEALED UNDER RULE 61G15-23.004, F.A.C.

---

# APPENDIX C

## LONG RANGE ESTIMATE

# FDOT Long Range Estimating System - Production

## R3: Project Details by Sequence Report

**Project:** 436928-1-22-01

**Letting Date:** 01/2099

**Description:** BURNT STORE RD FROM VAN BUREN PARKWAY TO CHARLOTTE CO/LINE

**District:** 01      **County:** 12 LEE      **Market Area:** 10      **Units:** English

**Contract Class:** 9      **Lump Sum Project:** N      **Design/Build:** Y      **Project Length:** 5.500 MI

**Project Manager:** NEM-AEH-SAA

**Version 12 Project Grand Total**

**\$127,990,449.19**

**Description:** December 2024 Unit Cost Update with Added Signal per PM - Copied from Version 10P (Lee County Portion) - 12/10/24

**Sequence:** 1 NDU - New Construction, Divided, Urban

**Net Length:** 5.510 MI  
29,095 LF

**Description:** Alt 3 - Lee County

### EARTHWORK COMPONENT

**User Input Data**

Description	Value
Standard Clearing and Grubbing Limits L/R	100.00 / 100.00
Incidental Clearing and Grubbing Area	0.00
Alignment Number	1
Distance	5.510
Top of Structural Course For Begin Section	105.00
Top of Structural Course For End Section	105.00
Horizontal Elevation For Begin Section	100.00
Horizontal Elevation For End Section	100.00
Front Slope L/R	6 to 1 / 6 to 1
Median Shoulder Cross Slope L/R	4.00 % / 4.00 %
Outside Shoulder Cross Slope L/R	2.00 % / 2.00 %
Roadway Cross Slope L/R	2.00 % / 2.00 %

**Pay Items**

Pay item	Description	Quantity Unit	Unit Price	Extended Amount
110-1-1	CLEARING & GRUBBING	133.58 AC	\$15,000.00	\$2,003,700.00
120-6	EMBANKMENT	645,127.45 CY	\$21.44	\$13,831,532.53
<b>Earthwork Component Total</b>				<b>\$15,835,232.53</b>

### ROADWAY COMPONENT

**User Input Data**

Description	Value
Number of Lanes	4
Roadway Pavement Width L/R	37.00 / 37.00
Structural Spread Rate	330
Friction Course Spread Rate	165

**Pay Items**

Pay item	Description	Quantity Unit	Unit Price	Extended Amount
160-4	TYPE B STABILIZATION	272,587.00 SY	\$8.19	\$2,232,487.53

285-709	OPTIONAL BASE,BASE GROUP 09	239,224.83 SY	\$25.94	\$6,205,492.09
334-1-13	SUPERPAVE ASPHALTIC CONC, TRAFFIC C	39,472.10 TN	\$180.15	\$7,110,898.82
337-7-83	ASPH CONC FC,TRAFFIC C,FC- 12.5,PG 76-22	19,736.05 TN	\$206.85	\$4,082,401.94

#### Pavement Marking Subcomponent

Description	Value
Include Thermo/Tape/Other	Y
Pavement Type	Asphalt
Solid Stripe No. of Paint Applications	1
Solid Stripe No. of Stripes	4
Skip Stripe No. of Paint Applications	1
Skip Stripe No. of Stripes	2

#### Pay Items

Pay item	Description	Quantity Unit	Unit Price	Extended Amount
706-1-3	RAISED PAVMT MARK, TYPE B	2,232.00 EA	\$4.49	\$10,021.68
710-11-101	PAINTED PAVT MARK,STD,WHITE,SOLID,6"	22.04 GM	\$1,522.57	\$33,557.44
710-11-131	PAINTED PAVT MARK,STD,WHITE,SKIP, 6"	11.02 GM	\$559.49	\$6,165.58
711-16-101	THERMOPLASTIC, STD-OTH, WHITE, SOLID, 6"	22.04 GM	\$5,832.06	\$128,538.60
711-16-131	THERMOPLASTIC, STD-OTH, WHITE, SKIP, 6"	11.02 GM	\$1,499.44	\$16,523.83

#### Peripherals Subcomponent

Description	Value
Off Road Bike Path(s)	0
Off Road Bike Path Width L/R	10.00 / 10.00
Bike Path Structural Spread Rate	165
Noise Barrier Wall Length	0.00
Noise Barrier Wall Begin Height	0.00
Noise Barrier Wall End Height	0.00

#### Pay Items

Pay item	Description	Quantity Unit	Unit Price	Extended Amount
160-4	TYPE B STABILIZATION	77,586.43 SY	\$8.19	\$635,432.86
285-701	OPTIONAL BASE,BASE GROUP 01	64,655.36 SY	\$19.73	\$1,275,650.25
334-1-13	SUPERPAVE ASPHALTIC CONC, TRAFFIC C	5,334.07 TN	\$180.15	\$960,932.71

#### Roadway Component Total

\$22,698,103.33

### SHOULDER COMPONENT

#### User Input Data

Description	Value
Total Outside Shoulder Width L/R	7.25 / 7.25
Total Outside Shoulder Perf. Turf Width L/R	5.00 / 5.00
Sidewalk Width L/R	0.00 / 0.00

#### Pay Items

Pay item	Description	Quantity Unit	Unit Price	Extended Amount
520-1-10	CONCRETE CURB & GUTTER, TYPE F	29,094.91 LF	\$39.21	\$1,140,811.42

520-1-10	CONCRETE CURB & GUTTER, TYPE F	29,094.91 LF	\$39.21	\$1,140,811.42
570-1-1	PERFORMANCE TURF	32,327.68 SY	\$3.64	\$117,672.76

**Erosion Control**

**Pay Items**

Pay item	Description	Quantity Unit	Unit Price	Extended Amount
104-10-3	SEDIMENT BARRIER	58,189.82 LF	\$1.85	\$107,651.17
104-11	FLOATING TURBIDITY BARRIER	1,377.60 LF	\$13.97	\$19,245.07
104-12	STAKED TURBIDITY BARRIER- NYL REINF PVC	1,377.60 LF	\$6.07	\$8,362.03
104-15	SOIL TRACKING PREVENTION DEVICE	6.00 EA	\$3,130.10	\$18,780.60
104-18	INLET PROTECTION SYSTEM	282.00 EA	\$152.32	\$42,954.24
107-1	LITTER REMOVAL	140.24 AC	\$44.50	\$6,240.68
107-2	MOWING	140.24 AC	\$70.44	\$9,878.51
<b>Shoulder Component Total</b>				<b>\$2,612,407.90</b>

**MEDIAN COMPONENT**

**User Input Data**

Description	Value
Total Median Width	24.00
Performance Turf Width	24.00

**Pay Items**

Pay item	Description	Quantity Unit	Unit Price	Extended Amount
520-1-7	CONCRETE CURB & GUTTER, TYPE E	58,189.82 LF	\$41.39	\$2,408,476.65
570-1-1	PERFORMANCE TURF	77,586.43 SY	\$3.64	\$282,414.61
<b>Median Component Total</b>				<b>\$2,690,891.26</b>

**DRAINAGE COMPONENT**

**Pay Items**

Pay item	Description	Quantity Unit	Unit Price	Extended Amount
425-1-351	INLETS, CURB, TYPE P-5, <10'	199.00 EA	\$9,074.61	\$1,805,847.39
425-1-451	INLETS, CURB, TYPE J-5, <10'	56.00 EA	\$14,601.98	\$817,710.88
425-1-521	INLETS, DT BOT, TYPE C, <10'	28.00 EA	\$9,283.15	\$259,928.20
425-2-41	MANHOLES, P-7, <10'	28.00 EA	\$8,244.27	\$230,839.56
430-175-124	PIPE CULV, OPT MATL, ROUND, 24"S/CD	14,584.00 LF	\$213.71	\$3,116,746.64
430-175-136	PIPE CULV, OPT MATL, ROUND, 36"S/CD	1,304.00 LF	\$322.14	\$420,070.56
430-175-148	PIPE CULV, OPT MATL, ROUND, 48"S/CD	27,552.00 LF	\$456.85	\$12,587,131.20
570-1-1	PERFORMANCE TURF	1,675.16 SY	\$3.64	\$6,097.58

**X-Items**

Pay item	Description	Quantity Unit	Unit Price	Extended Amount
400-4-1	CONC CLASS IV, CULVERTS	2,590.00 CY	\$2,168.60	\$5,616,674.00
415-1-1	REINF STEEL- ROADWAY	518,000.00 LB	\$1.39	\$720,020.00

**Drainage Component Total** **\$25,581,066.01**



---

**SIGNING COMPONENT**

<b>Pay Items</b>					
<b>Pay item</b>	<b>Description</b>	<b>Quantity</b>	<b>Unit</b>	<b>Unit Price</b>	<b>Extended Amount</b>
700-1-11	SINGLE POST SIGN, F&I GM, <12 SF	133.00	AS	\$518.92	\$69,016.36
700-1-12	SINGLE POST SIGN, F&I GM, 12-20 SF	12.00	AS	\$1,678.57	\$20,142.84
700-2-15	MULTI- POST SIGN, F&I GM, 51-100 SF	12.00	AS	\$10,012.59	\$120,151.08
700-2-16	MULTI- POST SIGN, F&I GM, 101-200 SF	12.00	AS	\$15,009.27	\$180,111.24
<b>Signing Component Total</b>					<b>\$389,421.52</b>

---

**SIGNALIZATIONS COMPONENT**

**Signalization 1**

<b>Description</b>	<b>Value</b>
Type	4 Lane Mast Arm
Multiplier	1
Description	

**Pay Items**

<b>Pay item</b>	<b>Description</b>	<b>Quantity</b>	<b>Unit</b>	<b>Unit Price</b>	<b>Extended Amount</b>
630-2-11	CONDUIT, F& I, OPEN TRENCH	750.00	LF	\$15.65	\$11,737.50
630-2-12	CONDUIT, F& I, DIRECTIONAL BORE	250.00	LF	\$36.53	\$9,132.50
632-7-1	SIGNAL CABLE- NEW OR RECO, FUR & INSTALL	1.00	PI	\$11,823.54	\$11,823.54
635-2-11	PULL & SPLICE BOX, F&I, 13" x 24"	16.00	EA	\$1,286.43	\$20,582.88
639-1-112	ELECTRICAL POWER SRV,F&I,OH,M,PUR BY CON	1.00	AS	\$5,761.80	\$5,761.80
639-2-1	ELECTRICAL SERVICE WIRE, F&I	60.00	LF	\$10.65	\$639.00
649-21-10	STEEL MAST ARM ASSEMBLY, F&I, 60'	4.00	EA	\$99,569.61	\$398,278.44
650-1-14	VEH TRAF SIGNAL,F&I ALUMINUM, 3 S 1 W	12.00	AS	\$1,874.80	\$22,497.60
653-1-11	PEDESTRIAN SIGNAL, F&I LED COUNT, 1 WAY	8.00	AS	\$1,152.75	\$9,222.00
660-1-102	LOOP DETECTOR INDUCTIVE, F&I, TYPE 2	12.00	EA	\$605.72	\$7,268.64
660-2-106	LOOP ASSEMBLY, F&I, TYPE F	12.00	AS	\$1,544.45	\$18,533.40
665-1-11	PEDESTRIAN DETECTOR, F&I, STANDARD	8.00	EA	\$422.36	\$3,378.88
670-5-111	TRAF CNTL ASSEM, F&I, NEMA, 1 PREEMPT	1.00	AS	\$62,125.32	\$62,125.32
700-3-101	SIGN PANEL, F&I GM, UP TO 12 SF	4.00	EA	\$431.93	\$1,727.72
<b>Signalizations Component Total</b>					<b>\$582,709.22</b>

---

**BRIDGES COMPONENT**

**Bridge 1**

<b>Description</b>	<b>Value</b>
--------------------	--------------

Estimate Type	SF Estimate
Primary Estimate	YES
Length (LF)	228.25
Width (LF)	62.67
Type	Low Level
Cost Factor	1.25
Structure No.	
Removal of Existing Structures area	6,720.00
Default Cost per SF	\$164.00
Factored Cost per SF	\$205.00
<b>Final Cost per SF</b>	<b>\$216.81</b>
<b>Basic Bridge Cost</b>	<b>\$2,932,407.64</b>
Description	

**Bridge Pay Items**

Pay item	Description	Quantity	Unit	Unit Price	Extended Amount
110-3	REMOVAL OF EXISTING STRUCTURES/BRIDGES	6,720.00	SF	\$70.38	\$472,953.60
400-2-10	CONC CLASS II, APPROACH SLABS	139.27	CY	\$994.68	\$138,529.08
415-1-9	REINF STEEL- APPROACH SLABS	24,372.25	LB	\$1.25	\$30,465.31
	<b>Bridge 1 Total</b>				<b>\$3,574,355.63</b>
	<b>Bridges Component Total</b>				<b>\$3,574,355.63</b>

---

**Sequence 1 Total** **\$73,964,187.40**

---

Sequence: 2 MIS - Miscellaneous Construction

Net Length: 0.000 MI  
0 LF

Description: Offsite drainage flow

---

**DRAINAGE COMPONENT**

**Pay Items**

Pay item	Description	Quantity	Unit	Unit Price	Extended Amount
430-175-124	PIPE CULV, OPT MATL, ROUND, 24"S/CD	800.00	LF	\$213.71	\$170,968.00
430-175-130	PIPE CULV, OPT MATL, ROUND, 30"S/CD	3,400.00	LF	\$269.81	\$917,354.00
430-175-136	PIPE CULV, OPT MATL, ROUND, 36"S/CD	2,200.00	LF	\$322.14	\$708,708.00

**X-Items**

Pay item	Description	Quantity	Unit	Unit Price	Extended Amount
425-1-552	INLETS, DT BOT, TYPE E, >10'	13.00	EA	\$16,168.37	\$210,188.81
430-175-142	PIPE CULV, OPT MATL, ROUND, 42"S/CD	1,200.00	LF	\$308.36	\$370,032.00
430-175-148	PIPE CULV, OPT MATL, ROUND, 48"S/CD	1,200.00	LF	\$456.85	\$548,220.00
430-175-154	PIPE CULV, OPT MATL, ROUND, 54"S/CD	1,200.00	LF	\$535.00	\$642,000.00
430-175-160	PIPE CULV, OPT MATL, ROUND, 60"S/CD	4,400.00	LF	\$607.91	\$2,674,804.00
430-175-166	PIPE CULV, OPT MATL, ROUND, 66"S/CD	3,600.00	LF	\$771.29	\$2,776,644.00
430-175-172	PIPE CULV, OPT MATL, ROUND, 72"S/CD	800.00	LF	\$997.14	\$797,712.00

**Drainage Component Total** \$9,816,630.81

---

**Sequence 2 Total** \$9,816,630.81

---

# FDOT Long Range Estimating System - Production

## R3: Project Details by Sequence Report

**Project:** 436928-1-22-01

**Letting Date:** 01/2099

**Description:** BURNT STORE RD FROM VAN BUREN PARKWAY TO CHARLOTTE CO/LINE

**District:** 01      **County:** 12 LEE      **Market Area:** 10      **Units:** English

**Contract Class:** 9      **Lump Sum Project:** N      **Design/Build:** Y      **Project Length:** 5.500 MI

**Project Manager:** NEM-AEH-SAA

**Version 12 Project Grand Total**

**\$127,990,449.19**

**Description:** December 2024 Unit Cost Update with Added Signal per PM - Copied from Version 10P (Lee County Portion) - 12/10/24

---

**Project Sequences Subtotal** **\$83,780,818.21**

102-1	Maintenance of Traffic	15.00 %	\$12,567,122.73
101-1	Mobilization	10.00 %	\$9,634,794.09

**Project Sequences Total** **\$105,982,735.03**

Project Unknowns	5.00 %	\$5,299,136.75
Design/Build	15.00 %	\$16,692,280.77

**Non-Bid Components:**

Pay item	Description	Quantity	Unit	Unit Price	Extended Amount
999-25	INITIAL CONTINGENCY AMOUNT (DO NOT BID)		LS	\$16,296.64	\$16,296.64

**Project Non-Bid Subtotal** **\$16,296.64**

**Version 12 Project Grand Total** **\$127,990,449.19**

# FDOT Long Range Estimating System - Production

## R3: Project Details by Sequence Report

**Project:** 436928-1-22-01

**Letting Date:** 01/2099

**Description:** BURNT STORE RD FROM VAN BUREN PARKWAY TO CHARLOTTE CO/LINE

**District:** 01      **County:** 12 LEE      **Market Area:** 10      **Units:** English

**Contract Class:** 9      **Lump Sum Project:** N      **Design/Build:** Y      **Project Length:** 5.500 MI

**Project Manager:** NEM-AEH-SAA

**Version 13 Project Grand Total**

**\$6,004,157.56**

**Description:** December 2024 Unit Cost Update from Version 11 (Charlotte County Portion) - 12/10/24

**Sequence:** 1 NDU - New Construction, Divided, Urban

**Net Length:** 0.284 MI  
1,500 LF

**Description:** Alt 3 - Charlotte County

### EARTHWORK COMPONENT

**User Input Data**

Description	Value
Standard Clearing and Grubbing Limits L/R	100.00 / 100.00
Incidental Clearing and Grubbing Area	0.00
Alignment Number	1
Distance	0.284
Top of Structural Course For Begin Section	105.00
Top of Structural Course For End Section	105.00
Horizontal Elevation For Begin Section	100.00
Horizontal Elevation For End Section	100.00
Front Slope L/R	6 to 1 / 6 to 1
Median Shoulder Cross Slope L/R	4.00 % / 4.00 %
Outside Shoulder Cross Slope L/R	2.00 % / 2.00 %
Roadway Cross Slope L/R	2.00 % / 2.00 %

**Pay Items**

Pay item	Description	Quantity	Unit	Unit Price	Extended Amount
110-1-1	CLEARING & GRUBBING	6.88	AC	\$51,295.36	\$352,912.08
120-6	EMBANKMENT	33,251.58	CY	\$22.50	\$748,160.55
<b>Earthwork Component Total</b>					<b>\$1,101,072.63</b>

### ROADWAY COMPONENT

**User Input Data**

Description	Value
Number of Lanes	4
Roadway Pavement Width L/R	37.00 / 37.00
Structural Spread Rate	330
Friction Course Spread Rate	165

**Pay Items**

Pay item	Description	Quantity	Unit	Unit Price	Extended Amount
160-4	TYPE B STABILIZATION	14,053.78	SY	\$16.19	\$227,530.70
285-709	OPTIONAL BASE,BASE GROUP 09	12,333.73	SY	\$25.94	\$319,936.96

334-1-13	SUPERPAVE ASPHALTIC CONC, TRAFFIC C	2,035.07 TN	\$180.15	\$366,617.86
337-7-83	ASPH CONC FC,TRAFFIC C,FC- 12.5,PG 76-22	1,017.53 TN	\$240.75	\$244,970.35

#### Pavement Marking Subcomponent

Description	Value
Include Thermo/Tape/Other	Y
Pavement Type	Asphalt
Solid Stripe No. of Paint Applications	1
Solid Stripe No. of Stripes	4
Skip Stripe No. of Paint Applications	1
Skip Stripe No. of Stripes	2

#### Pay Items

Pay item	Description	Quantity	Unit	Unit Price	Extended Amount
706-1-3	RAISED PAVMT MARK, TYPE B	115.00	EA	\$4.49	\$516.35
710-11-101	PAINTED PAVT MARK,STD,WHITE,SOLID,6"	1.14	GM	\$1,522.57	\$1,735.73
710-11-131	PAINTED PAVT MARK,STD,WHITE,SKIP, 6"	0.57	GM	\$559.49	\$318.91
711-16-101	THERMOPLASTIC, STD-OTH, WHITE, SOLID, 6"	1.14	GM	\$5,832.06	\$6,648.55
711-16-131	THERMOPLASTIC, STD-OTH, WHITE, SKIP, 6"	0.57	GM	\$1,910.68	\$1,089.09

#### Peripherals Subcomponent

Description	Value
Off Road Bike Path(s)	0
Off Road Bike Path Width L/R	10.00 / 10.00
Bike Path Structural Spread Rate	165
Noise Barrier Wall Length	0.00
Noise Barrier Wall Begin Height	0.00
Noise Barrier Wall End Height	0.00

#### Pay Items

Pay item	Description	Quantity	Unit	Unit Price	Extended Amount
160-4	TYPE B STABILIZATION	4,000.13	SY	\$16.19	\$64,762.10
285-701	OPTIONAL BASE,BASE GROUP 01	3,333.44	SY	\$37.34	\$124,470.65
334-1-13	SUPERPAVE ASPHALTIC CONC, TRAFFIC C	275.01	TN	\$180.15	\$49,543.05

#### Roadway Component Total

\$1,408,140.30

### SHOULDER COMPONENT

#### User Input Data

Description	Value
Total Outside Shoulder Width L/R	7.25 / 7.25
Total Outside Shoulder Perf. Turf Width L/R	5.00 / 5.00
Sidewalk Width L/R	0.00 / 0.00

#### Pay Items

Pay item	Description	Quantity	Unit	Unit Price	Extended Amount
520-1-10	CONCRETE CURB & GUTTER, TYPE F	1,500.05	LF	\$52.21	\$78,317.61

520-1-10	CONCRETE CURB & GUTTER, TYPE F	1,500.05 LF	\$52.21	\$78,317.61
570-1-1	PERFORMANCE TURF	1,666.72 SY	\$4.10	\$6,833.55

**Erosion Control**

**Pay Items**

Pay item	Description	Quantity Unit	Unit Price	Extended Amount
104-10-3	SEDIMENT BARRIER	3,000.10 LF	\$2.07	\$6,210.21
104-11	FLOATING TURBIDITY BARRIER	71.03 LF	\$13.97	\$992.29
104-12	STAKED TURBIDITY BARRIER- NYL REINF PVC	71.03 LF	\$6.07	\$431.15
104-15	SOIL TRACKING PREVENTION DEVICE	1.00 EA	\$3,130.10	\$3,130.10
104-18	INLET PROTECTION SYSTEM	15.00 EA	\$152.32	\$2,284.80
107-1	LITTER REMOVAL	7.23 AC	\$44.50	\$321.74
107-2	MOWING	7.23 AC	\$70.44	\$509.28
<b>Shoulder Component Total</b>				<b>\$177,348.34</b>

**MEDIAN COMPONENT**

**User Input Data**

Description	Value
Total Median Width	24.00
Performance Turf Width	24.00

**Pay Items**

Pay item	Description	Quantity Unit	Unit Price	Extended Amount
520-1-7	CONCRETE CURB & GUTTER, TYPE E	3,000.10 LF	\$41.39	\$124,174.14
570-1-1	PERFORMANCE TURF	4,000.13 SY	\$4.10	\$16,400.53
<b>Median Component Total</b>				<b>\$140,574.67</b>

**DRAINAGE COMPONENT**

**Pay Items**

Pay item	Description	Quantity Unit	Unit Price	Extended Amount
425-1-351	INLETS, CURB, TYPE P-5, <10'	11.00 EA	\$9,074.61	\$99,820.71
425-1-451	INLETS, CURB, TYPE J-5, <10'	3.00 EA	\$17,822.42	\$53,467.26
425-1-521	INLETS, DT BOT, TYPE C, <10'	2.00 EA	\$9,283.15	\$18,566.30
425-2-41	MANHOLES, P-7, <10'	2.00 EA	\$8,244.27	\$16,488.54
430-175-124	PIPE CULV, OPT MATL, ROUND, 24"S/CD	752.00 LF	\$213.71	\$160,709.92
430-175-136	PIPE CULV, OPT MATL, ROUND, 36"S/CD	72.00 LF	\$336.62	\$24,236.64
430-175-148	PIPE CULV, OPT MATL, ROUND, 48"S/CD	1,424.00 LF	\$482.94	\$687,706.56
570-1-1	PERFORMANCE TURF	86.37 SY	\$4.10	\$354.12
<b>Drainage Component Total</b>				<b>\$1,061,350.05</b>

**SIGNING COMPONENT**

**Pay Items**

Pay item	Description	Quantity Unit	Unit Price	Extended Amount
----------	-------------	---------------	------------	-----------------

700-1-11	SINGLE POST SIGN, F&I GM, <12 SF	7.00 AS	\$637.52	\$4,462.64
700-1-12	SINGLE POST SIGN, F&I GM, 12-20 SF	1.00 AS	\$2,101.47	\$2,101.47
700-2-15	MULTI- POST SIGN, F&I GM, 51-100 SF	1.00 AS	\$10,012.59	\$10,012.59
700-2-16	MULTI- POST SIGN, F&I GM, 101-200 SF	1.00 AS	\$15,009.27	\$15,009.27

**Signing Component Total** \$31,585.97

---

**Sequence 1 Total** \$3,920,071.96

---



# FDOT Long Range Estimating System - Production

## R3: Project Details by Sequence Report

**Project:** 436928-1-22-01

**Letting Date:** 01/2099

**Description:** BURNT STORE RD FROM VAN BUREN PARKWAY TO CHARLOTTE CO/LINE

**District:** 01      **County:** 12 LEE      **Market Area:** 10      **Units:** English

**Contract Class:** 9      **Lump Sum Project:** N      **Design/Build:** Y      **Project Length:** 5.500 MI

**Project Manager:** NEM-AEH-SAA

**Version 13 Project Grand Total**

**\$6,004,157.56**

**Description:** December 2024 Unit Cost Update from Version 11 (Charlotte County Portion) - 12/10/24

**Project Sequences Subtotal** **\$3,920,071.96**

102-1	Maintenance of Traffic	15.00 %	\$588,010.79
101-1	Mobilization	10.00 %	\$450,808.28

**Project Sequences Total** **\$4,958,891.03**

Project Unknowns	5.00 %	\$247,944.55
Design/Build	15.00 %	\$781,025.34

**Non-Bid Components:**

Pay item	Description	Quantity	Unit	Unit Price	Extended Amount
999-25	INITIAL CONTINGENCY AMOUNT (DO NOT BID)		LS	\$16,296.64	\$16,296.64

**Project Non-Bid Subtotal** **\$16,296.64**

**Version 13 Project Grand Total** **\$6,004,157.56**

---

# APPENDIX D

## TURNING MOVEMENT COUNTS AND TURNING MOVEMENT VOLUMES

### Existing (2021) Turning Movement Counts

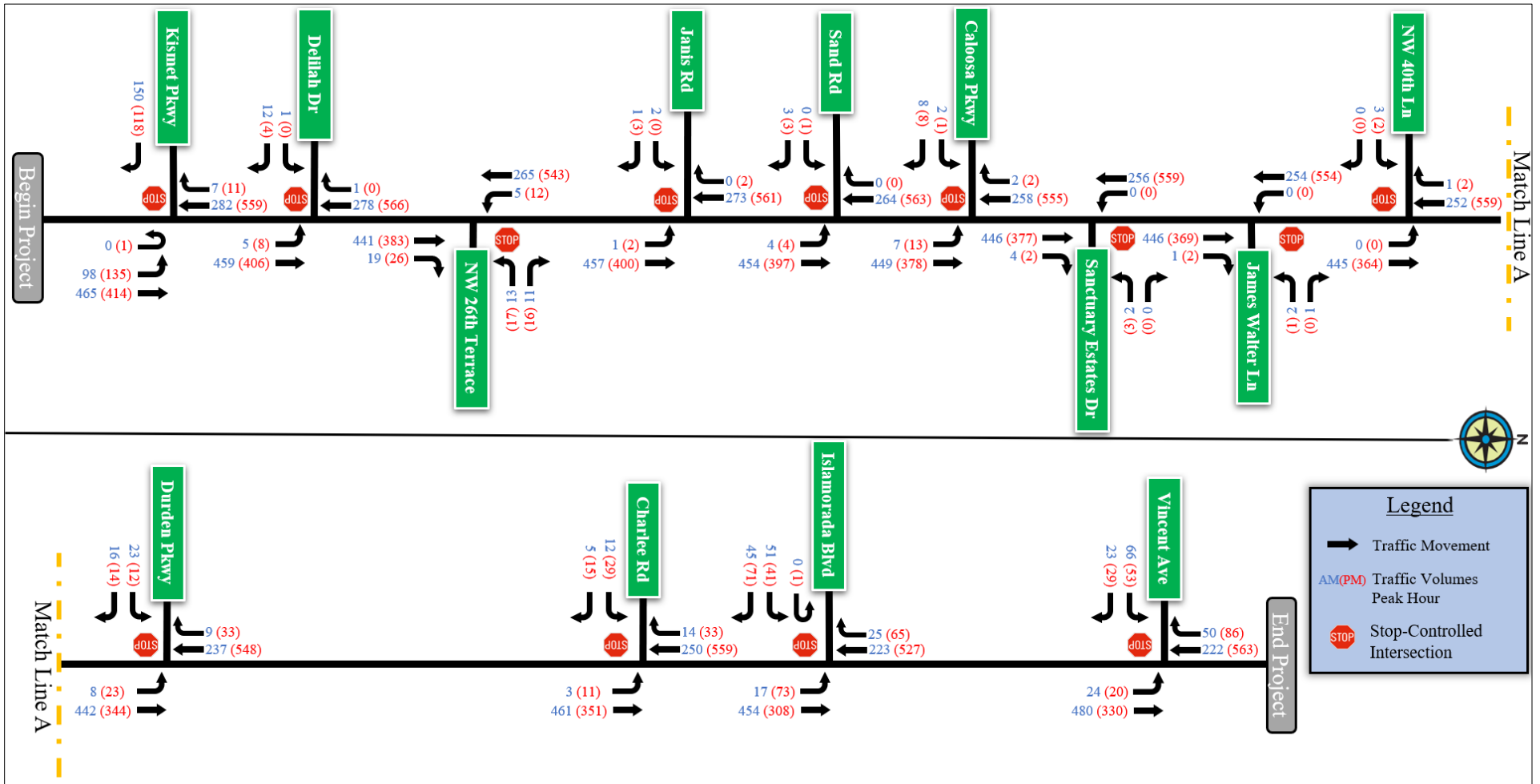

## No-Build Opening Year (2025) Turning Movement Volumes

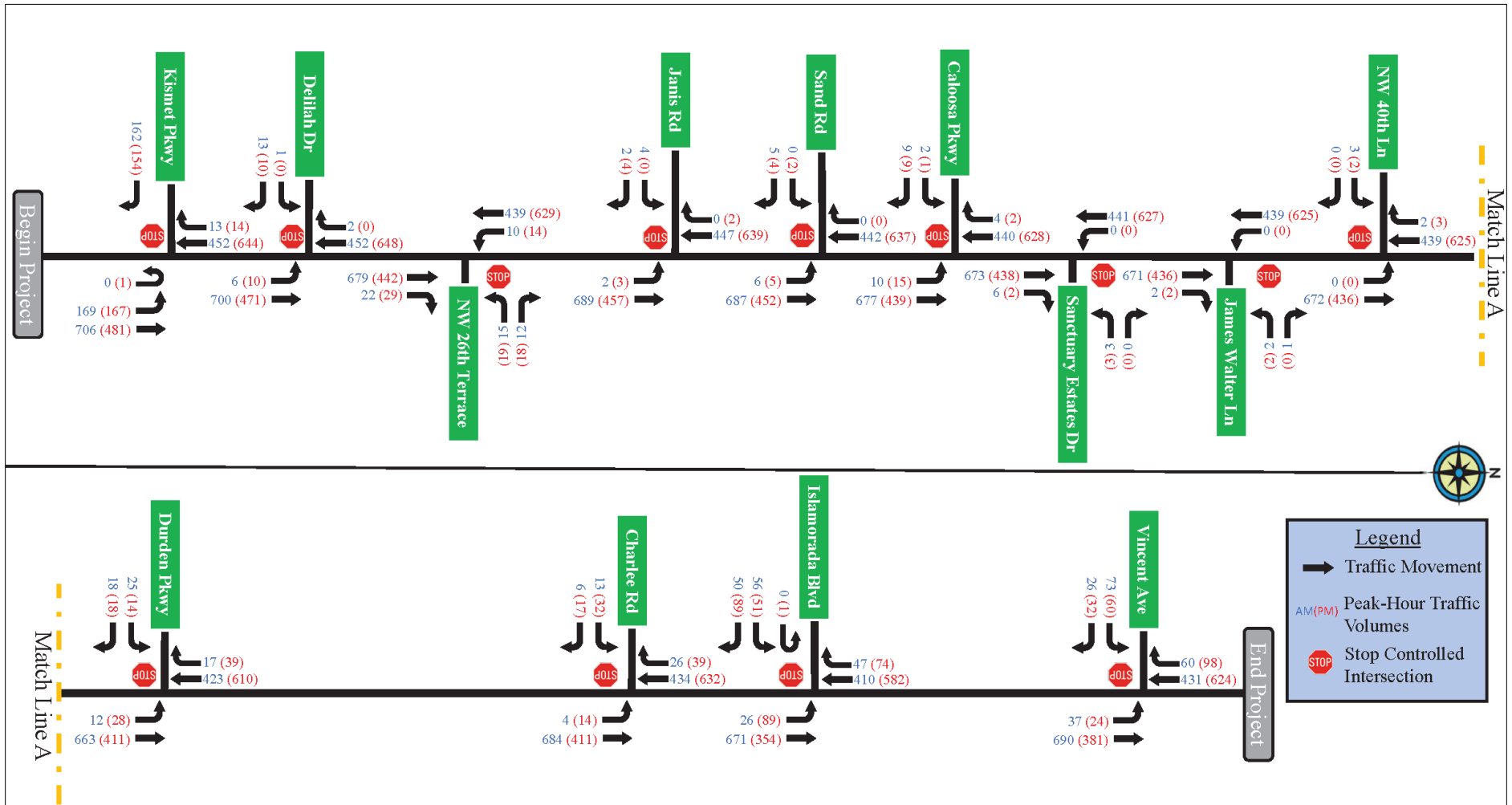

## No-Build Design Year (2045) Turning Movement Volumes

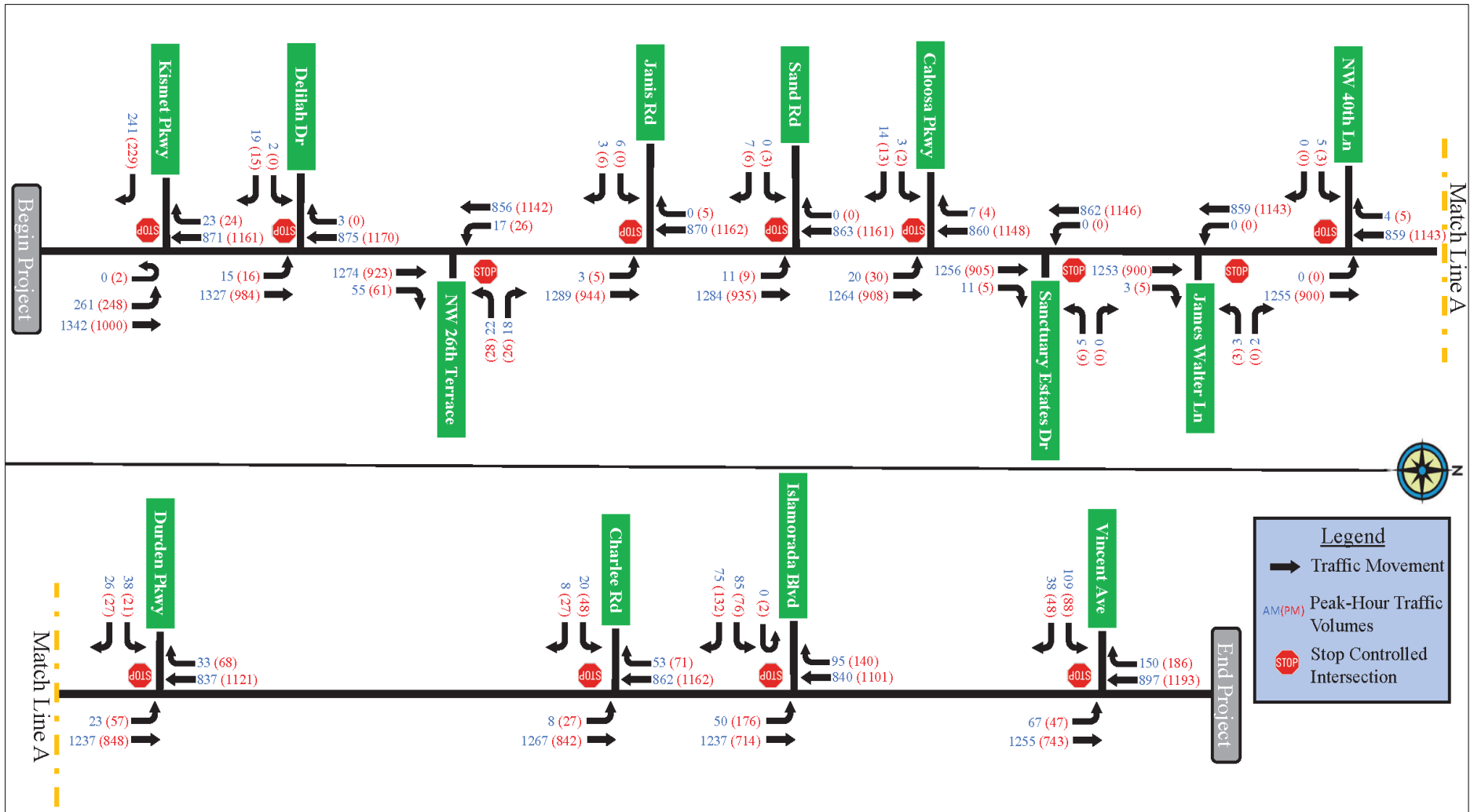

### Build Opening Year (2025) Turning Movement Volumes

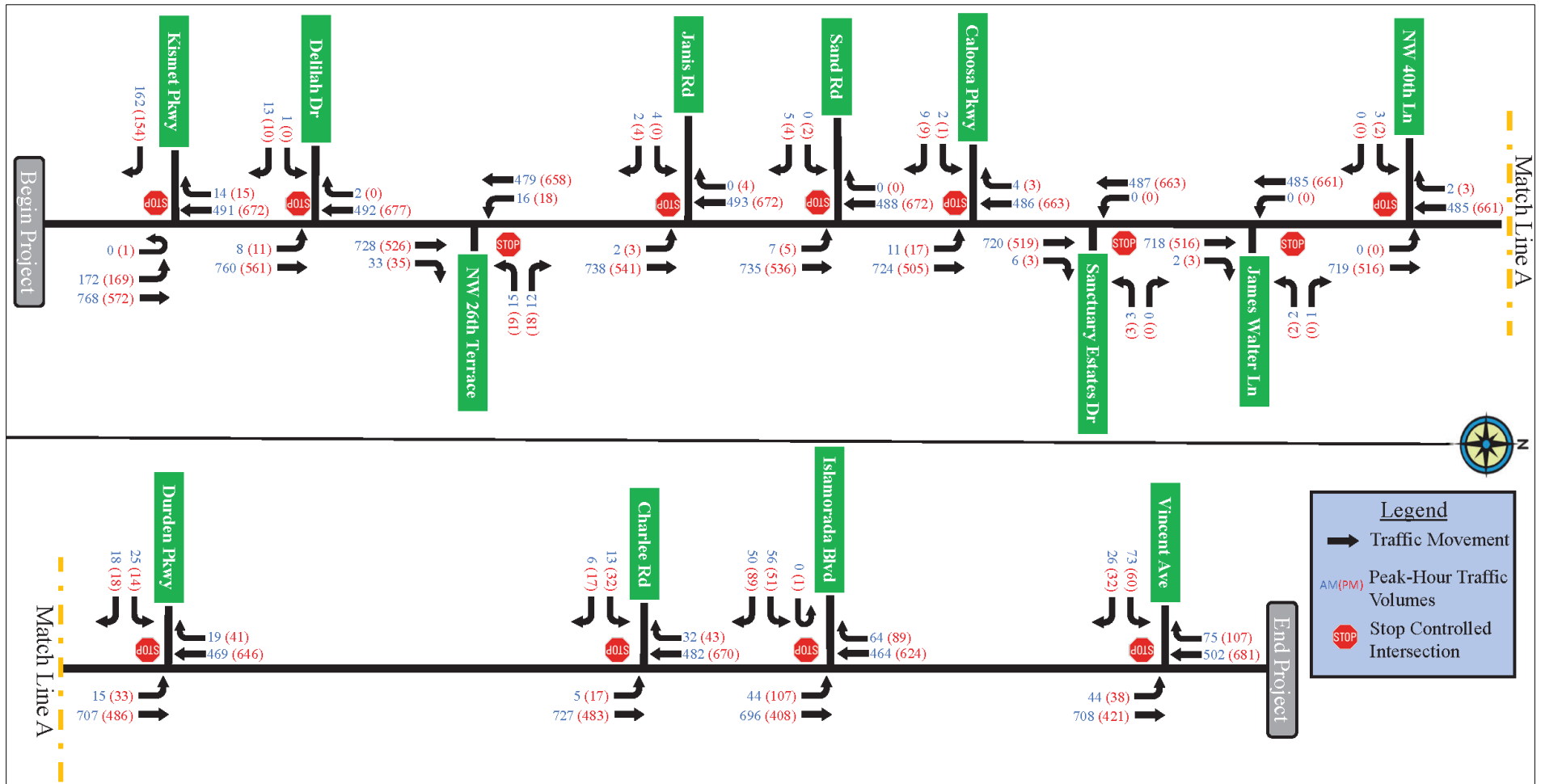

See Appendix G for TMC updates at Vincent Avenue

### Build Design Year (2045) Turning Movement Volumes

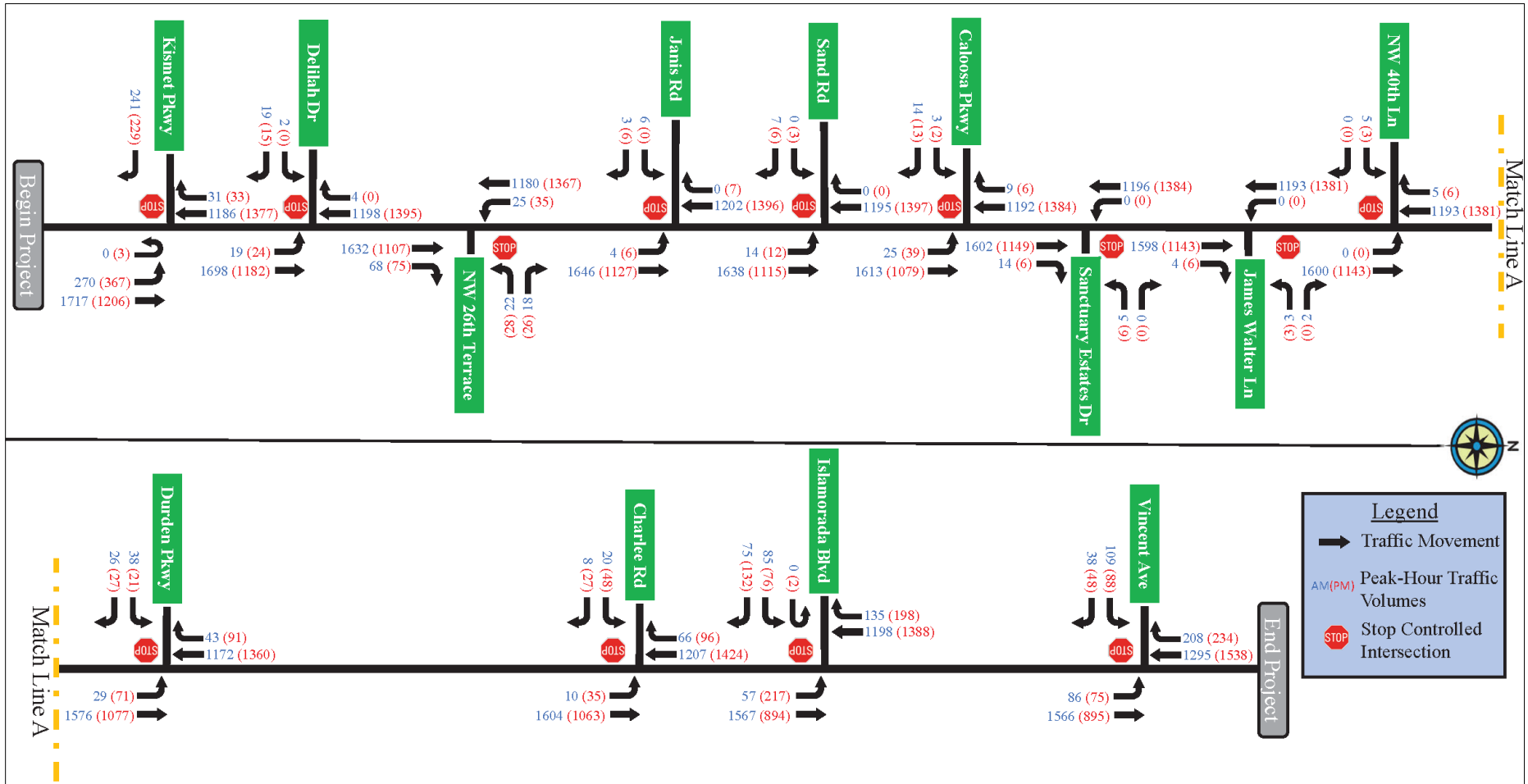

See Appendix G for TMC updates at Vincent Avenue

---

# APPENDIX E

## LEE COUNTY ACCESS MANAGEMENT RESOLUTION



LEE COUNTY RESOLUTION NO. 20-09-26

**A RESOLUTION OF THE BOARD OF COUNTY COMMISSIONERS  
OF LEE COUNTY, FLORIDA, FOR DESIGNATION OF BURNT  
STORE ROAD AS A CONTROLLED ACCESS ROAD AND  
ESTABLISHMENT OF PERMANENT ACCESS POINTS.**

**WHEREAS**, section 10-285(h) of the Lee County Land Development Code provides for the designation of certain streets in Lee County as "controlled access" facilities to which permanent access points are restricted to locations established and set by design study and plans adopted by resolution of the Lee County Board of County Commissioners; and

**WHEREAS**, the Board of County Commissioners retains the right and authority to exercise its police power to modify roadway median openings, access points and turning movements to protect the health, safety, and welfare of the traveling public; and

**NOW, THEREFORE, BE IT RESOLVED** by the Board of County Commissioners of Lee County, Florida, that:

1. Burnt Store Road (CR 765), from Pine Island Road (SR 78) north to the Charlotte County Line including its intersections, is designated a controlled access road facility.
2. Absent subsequent Board action in accordance with applicable County regulations, the connection points are limited to those mapped in attached Exhibit A and identified on Exhibit B. Provided; however, no vested right to a particular connection point location is granted by virtue of adopting Exhibit A. The County retains full power and authority to exercise its police power to modify connection points, median openings, and turning movements to protect the health, safety, and welfare of the traveling public.
3. Until the ultimate 6-lane superstreet is constructed and the 2-lane undivided frontage road on the west side is constructed and placed into service, all access to the existing southbound lanes from private properties will:
  - a. Be limited to right-in/right-out movements,
  - b. Be no closer than is specified in County codes for high-speed arterial streets,
  - c. Require right turn lanes to commercial developments and multi-family developments,
  - d. Require joint or cross access between commercial developments,
  - e. In cooperation with the City of Cape Coral, require an on-property turn-around for single-family and two-family residential developments, so that there is no backing into Burnt Store Road,
  - f. Limit access to corner lots to the side streets,
  - g. Be no parking on the right-of-way of Burnt Store Road.
4. Access to the existing southbound lanes of Burnt Store Road does not grant access to the future southbound lanes of the Burnt Store Road superstreet.
5. Access to properties adjacent to Burnt Store Road frontage roads after the construction of the southbound superstreet lanes is not controlled by this resolution.

Commissioner Manning made a motion to adopt the foregoing resolution, seconded by Commissioner Sandelli. The vote was as follows:

John E. Manning	<u>Aye</u>
Cecil L Pendergrass	<u>Aye</u>
Ray Sandelli	<u>Aye</u>
Brian Hamman	<u>Aye</u>
Franklin B. Mann	<u>Aye</u>

Duly passed and adopted this 15th day of September, 2020.

ATTEST:  
LINDA DOGGETT, CLERK

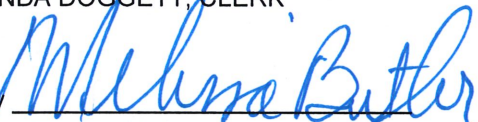
By   
Deputy Clerk

BOARD OF COUNTY COMMISSIONERS  
OF LEE COUNTY, FLORIDA

By   
Brian Hamman, Chair



APPROVED AS TO FORM FOR THE  
RELIANCE OF LEE COUNTY ONLY

By   
Office of the Lee County Attorney

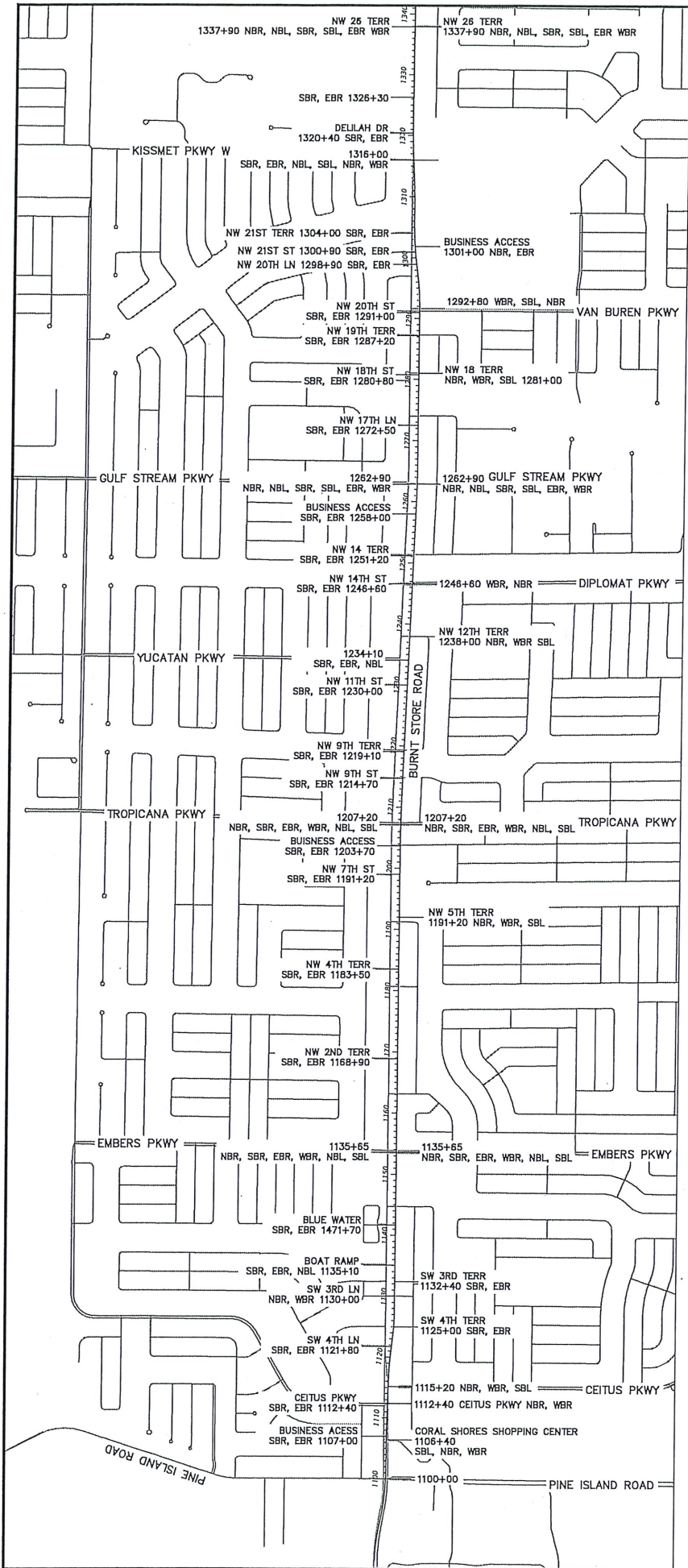

LEE COUNTY  
DEPARTMENT OF TRANSPORTATION  
BURNT STORE ROAD  
DESIGNATED ACCESS POINTS

EXHIBIT A  
Pg. 1 of 2

ADOPTED 00/00/00 PER RESOLUTION \*00-00-00

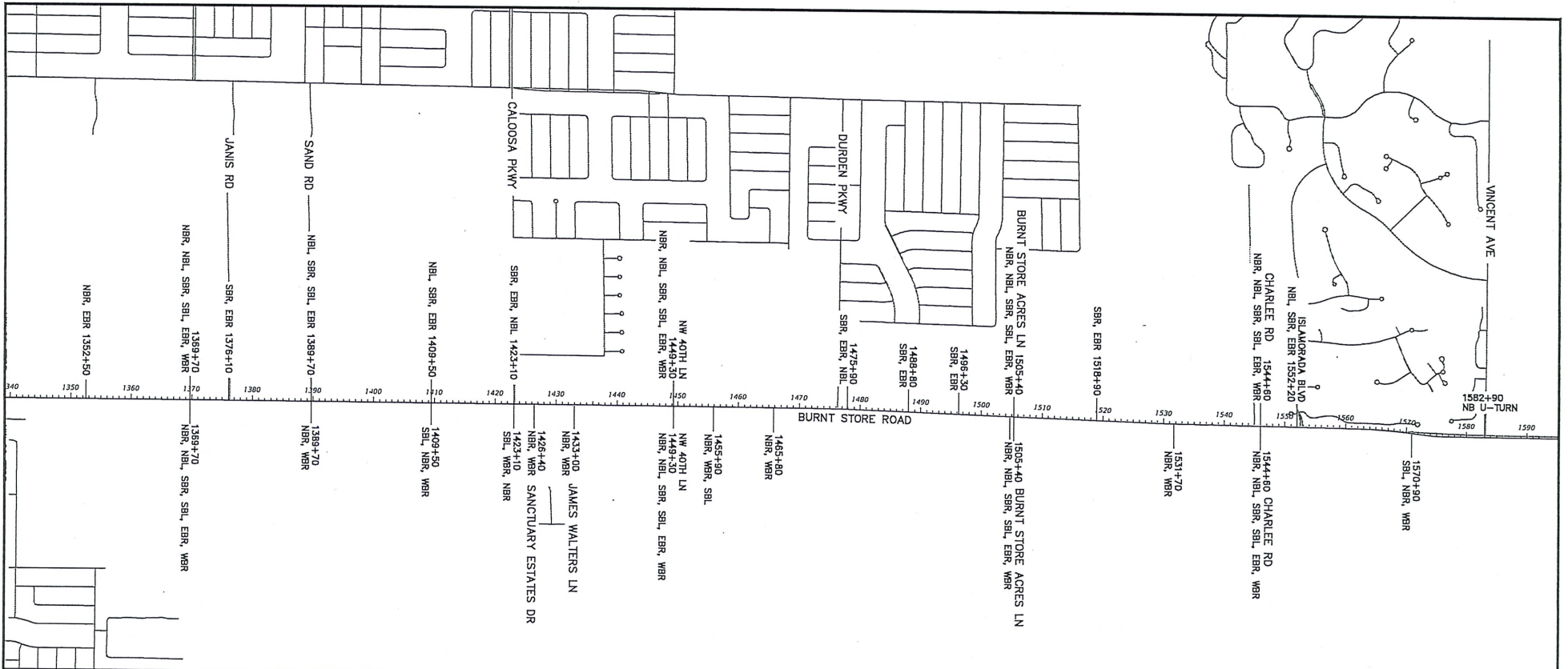

LEE COUNTY  
DEPARTMENT OF TRANSPORTATION

BURNT STORE ROAD  
DESIGNATED ACCESS POINTS

ADOPTED 00/00/00 PER RESOLUTION \*00-00-00

Lee County Board of County Commissioners Resolution No. \_\_\_\_\_

Exhibit B: Burnt Store Road Designated Access Points

STA	Location	Side	Movements	Comment
1100+00	Pine Island Rd	All	All	
1106+40	Coral Shores Shopping Center	east side	SBL, NBR, WBR	SBL is Temporary, until frontage road is built
1107+00	Business Access	west side	SBR, EBR	Temporary, until frontage road is built
1112+40	Ceitus Pkwy	east side	NBR, WBR	Temporary, until frontage road is built
1112+40	Ceitus Pkwy	west side	SBR, EBR	Temporary, until frontage road is built
1115+20	Ceitus Pkwy	east side	NBR, WBR, SBL	
1121+80	SW 4th Ln	west side	SBR, EBR	Temporary, until frontage road is built
1125+00	SW 4th Terr	west side	SBR, EBR	Temporary, until frontage road is built
1130+00	SW 3rd Ln	east side	NBR, WBR	
1132+40	SW 3rd Terr	west side	SBR, EBR	Temporary, until frontage road is built
1135+10	Boat Ramp	west side	SBR, EBR, NBL	
1141+70	Blue Water	west side	SBR, EBR	Temporary, until frontage road is built
1153+65	Embers Pkwy	Both	NBR, SBR, EBR, WBR, NBL, SBL	
1168+90	NW 2nd Terr	west side	SBR, EBR	Temporary, until frontage road is built
1183+50	NW 4th Terr	west side	SBR, EBR	Temporary, until frontage road is built
1190+20	NW 5th Terr	east side	NBR, WBR, SBL	
1198+90	NW 7th St	west side	SBR, EBR	Temporary, until frontage road is built
1203+70	Business Access	west side	SBR, EBR	Temporary, until frontage road is built
1207+20	Tropicanna Pkwy	Both	NBR, SBR, EBR, WBR, NBL, SBL	
1214+70	NW 9th St	west side	SBR, EBR	Temporary, until frontage road is built
1219+10	NW 9th Terr	west side	SBR, EBR	Temporary, until frontage road is built
1230+0	NW 11th St	west side	SBR, EBR	Temporary, until frontage road is built
1234+10	Yucatan Pkwy	west side	SBR, EBR, NBL	
1238+0	NW 12th Terr	east side	NBR, WBR, SBL	
1246+60	Diplomat Pkwy	east side	WBR, NBR	
1246+60	NW 14th St	west side	SBR, EBR	
1251+20	NW 14th Terr	west side	SBR, EBR	
1258+0	Business Access	west side	SBR, EBR	
1262+90	Gulfstream Pkwy	Both	NBR,NBL, SBR,SBL, EBR,WBR	
1272+50	NW 17th Ln	west side	SBR, EBR	Temporary, until frontage road is built
1280+80	NW 18th St	west side	SBR, EBR	Temporary, until frontage road is built
1281+0	NW 18th Terr	east side	NBR, WBR, SBL	
1287+20	NW 19th Terr	west side	SBR, EBR	Temporary, until frontage road is built
1291+0	NW 20th St	west side	SBR, EBR	Temporary, until frontage road is built
1292+80	Van Buren Pkwy	east side	WBR, SBL, NBR	
1298+90	NW 20th Ln	west side	SBR, EBR	Temporary, until frontage road is built
1300+90	NW 21st St	west side	SBR, EBR	Temporary, until frontage road is built
1301+00	Business Access	east side	NBR, WBR	
1304+00	NW 21st Terr	west side	SBR, EBR	Temporary, until frontage road is built
1316+00	Kismet Pkwy	Both	SBR, EBR, NBL, SBL, NBR, WBR	
1320+40	Delillah Dr	west side	SBR, EBR	
1326+30		west side	SBR, EBR	
1337+90	NW 26th Terr	Both	NBR,NBL, SBR,SBL, EBR,WBR	
1352+50		west side	NBR, EBR	
1369+70		Both	NBR,NBL, SBR,SBL, EBR,WBR	
1376+10	Janis Rd	west side	SBR, EBR	
1389+70	Sand Rd	Both	NBL, SBR,SBL, EBR, WBR, NBR	
1409+50		west side	NBL, SBR,SBL, EBR, WBR, NBR	
1423+10	Caloosa Pkwy	Both	SBR, EBR, NBL, SBL, NBR, WBR	Access to the east side is contingent on realignment of the intersection
1426+40	Sanctuary Estates Dr	east side	NBR, WBR	
1433+0	James Walters Ln	east side	NBR, WBR, SBL	
1449+30	NW 40th Ln	Both	NBR,NBL, SBR,SBL, EBR,WBR	
1455+90		east side	NBR, WBR, SBL	
1465+80		east side	NBR, WBR	
1475+90	Durden Pkwy	west side	SBR, EBR, NBL	
1488+80		west side	SBR, EBR	
1496+30		west side	SBR, EBR	
1504+40	Burnt Store Acres Ln	Both	NBR,NBL, SBR,SBL, EBR,WBR	
1518+90		west side	SBR, EBR	
1531+70		east side	NBR, WBR	
1544+60	Charlee Rd	Both	NBR,NBL, SBR,SBL, EBR,WBR	
1552+20	Islamorada Blvd	west side	NBL, SBR, EBR	
1570+90		east side	SBL, NBR, WBR	
1582+90	County Line		NB U-TURN	

All Stationing is +/-50 feet

---

# APPENDIX F

## FLOODPLAIN UPDATE MEMORANDUM

# Floodplain Update Technical Memorandum

**Date:** January 17, 2025  
**Project:** Burnt Store Road PD&E Study  
From Van Buren Parkway to the Charlotte County Line  
FPID #436928-1-22-01  
ETDM #14380  
**To:** Ms. Kristin Caruso  
Scalar Consulting Group, Inc.  
**From:** Ms. Melinda Fischl  
Conсор Engineers, LLC.  
**Re:** FEMA FIRM Updates

---

## Introduction

The Federal Emergency Management Agency (FEMA) updated the Flood Insurance Rate Maps (FIRM) and the Flood Insurance Study (FIS) for the project area with an effective date of November 17, 2022. Figure 1 depicts the project limits with the updated floodplain zones and limits. The March 2023 Location Hydraulics Report (LHR) and Pond Siting Report (PSR) utilized the FEMA FIRMs with an effective date of August 28, 2008, which indicated a portion of the project was within the 100-year floodplain (Zone AE, elevation 6.0' NAVD). Additionally, the March 2023 reports also indicated the Lee County FIRMs with an effective date of August 25, 2020, depicting the project outside the 100-year floodplain. The March 2023 LHR and PSR utilized the FEMA FIRMs 100-year elevation floodplain as a conservative approach.

The March 2023 LHR concluded and recommended that “roadway widening from project improvements will result in impacts to the adjacent FEMA Floodplains. The anticipated floodplain impacts due to the proposed roadway widening were calculated and floodplain compensation alternatives were identified. The floodplain impacts calculations are conservative and should be revised during design when survey and geotechnical data becomes available. Floodplain compensation should be provided in the area designated as Pond 2 and Floodplain Compensation Area, in addition to Pond 2B and Pond 2C, which also serve as stormwater management facilities for treatment and attenuation.”

## FEMA Floodplain Impacts

The November 2022 FEMA FIRMs increased the 100-year floodplain elevations (Zone AE) from 6.0' NAVD to 7.0' NAVD for the majority of the project. The beginning of the project from Van Buren Parkway to the Gator Slough Canal 100-year Zone AE elevation is now 8.0' NAVD on the west side only. In addition to the increase in floodplain elevation the floodplain extents along Burnt Store Road now include the project area (roadway from right-of-way to right-of-way) from Kismet Parkway West to just south of Caloosa Parkway, an increase of 10,300 linear feet of impacts. Additionally, preferred alternative ponds 1A and 2C are included within the new floodplain limits.

These updates results in an increase in floodplain impacts from 8.24 acre-feet to 25.07 acre-feet.

## Mitigation

There are various ways to mitigate the floodplain impacts, such as:

- The November 17, 2022, FIS (FEMA FIS for Lee County, Florida and Incorporated Areas, Volumes 1-15, FIS number 12071CV001C) shows the entire floodplain upper elevation limits are based on Tidal Stillwater Elevations. The coastal transects extend from Charlotte Harbor through the project limits, further indicating the floodplain is tidally influenced. Tidally influenced floodplains are not required to provide compensation. Furthermore, the additional impervious area from the widening of Burnt Store Road will not increase the elevation of Charlotte Harbor and will show there are de minimus impacts.
- A Letter of Map Revision (LOMR) for the roadway impacts could be obtained from FEMA. The LOMR would reflect that the roadway elevations in the FEMA maps may not accurately reflect the actual roadway elevations.
- Additional Geotechnical borings to determine groundwater elevation fluctuations during the design phase may result in less impacts to the floodplain. The borings during the PD&E phase were shallow and performed in June 2020.
- The Environmental markers for the wetlands and stainlines on the trees should also be considered for seasonal high groundwater elevations, which may reduce floodplain impacts.

The final determination of the floodplain impacts will be made during the design phase.



# FLOODPLAIN UPDATE TECHNICAL MEMO

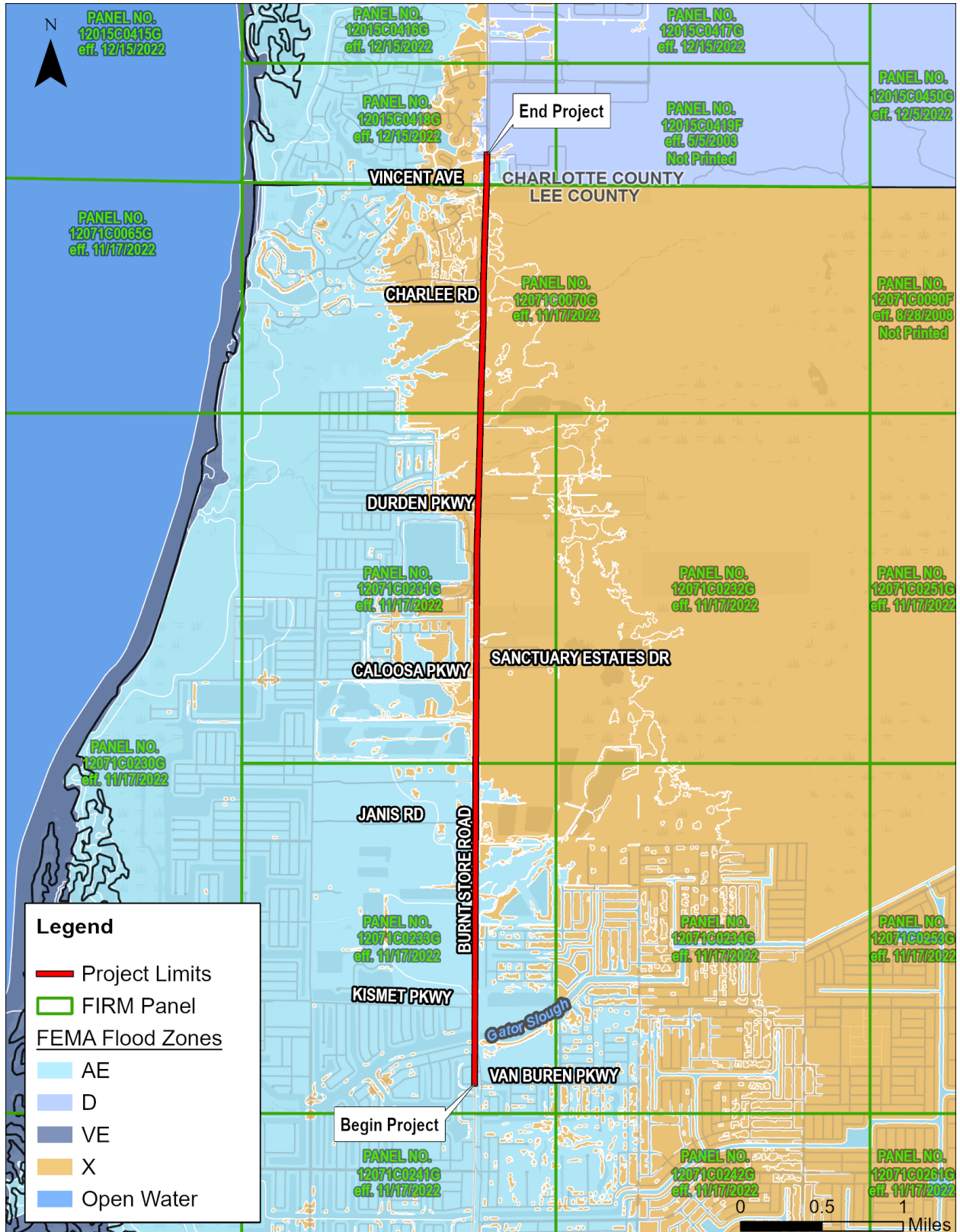

Figure 1

---

# APPENDIX G

## INTERSECTION CONTROL EVALUATION TECHNICAL MEMORANDUM

## CERTIFICATION

AGENCY: Florida Department of Transportation  
801 North Broadway Avenue  
Bartow, Florida 33831-1249

I hereby certify that I am a registered engineer in the State of Florida practicing with Scalar Consulting Group Inc. (Scalar), authorized to operate as an engineering business, headquartered at 5713 Corporate Way, Suite 200, West Palm Beach, Florida 33407, and that I have reviewed or approved the calculations, findings, opinions, conclusions, or technical advice hereby reported for:

PROJECT: **Intersection Control Evaluation (ICE) Stage 1**

LOCATION: **Burnt Store Road at Vincent Avenue  
Lee and Charlotte Counties, Florida**

I acknowledge that the procedures and references used to develop the information contained in this memorandum are standard to the professional practice of civil engineering as applied through professional judgment and experience.

Engineer in Responsible Charge: Giridhar Jeedigunta

Professional Registration No. 57490

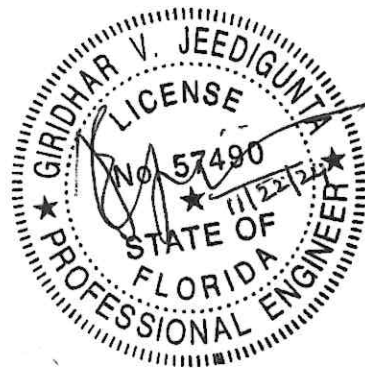

# Technical Memorandum

---

**Date:** November 25, 2024

**To:** Walter Breuggeman, P.E., Traffic Services Program Engineer  
Susan Joel, P.E., PTOE, Senior Engineer, Atkins in-house support

**From:** Scalar Consulting Group Inc.

**Subject:** ICE-Stage 1 Analysis for the Vincent Avenue at Burnt Store Road Intersection

**Project:** Burnt Store Road PD&E Study from Van Buren Parkway to Charlotte County Line

**FPID:** 436928-1

---

This document summarizes the project information and the procedures used in developing the Intersection Control Evaluation (ICE) Stage 1 Summary Report for the intersection of Vincent Avenue at Burnt Store Road.

At the direction of the Florida Department of Transportation (FDOT), Scalar Consulting Group Inc. (Scalar) conducted the ICE analyses for the intersection of Vincent Avenue at Burnt Store Road reflecting the two highest peak hours, the Midday and the PM peaks. The peak hour conditions for Existing Year (2024), Opening Year (2025), and Design Year (2045) were analyzed in accordance with the 2024 FDOT Manual on Intersection Control Evaluation.

Through regular coordination with Lee County and Charlotte County, the data needs for the project and processes for the analyses were identified. In addition, local preferences for the operational control of the intersection were vetted. The Burnt Store Marina Community was kept informed through public meetings. A signal warrant analysis was conducted with latest traffic volumes and crash data for the existing conditions. The ICE analyses with Capacity Analysis at Junctions (CAP-X) and Safety Performance for Intersection Control Evaluation (SPICE) were performed to identify viable intersection control options that would meet volume to capacity and Safe System for Intersections (SSI) requirements.

Results of the ICE analyses led to three viable intersection control options, namely Signalized Restricted Crossing U-Turn (RCUT), Traffic Signal, or a Continuous Green T (CGT). Based on the local preferences for the corridor, right-of-way requirements, environmental constraints, constructability and operational considerations, a single control strategy is being recommended for the intersection.

## **Project information:**

- **Project Purpose and Need:** The primary purpose of the project is to improve the local and regional transportation network while also providing multimodal pathways along Burnt Store Road. Widening of Burnt Store Road from 2 lanes to 4 lanes is expected to improve flow of traffic, facilitate emergency evacuations, and enhance safety.
- **Intersection Characteristics:** Burnt Store Road is a 2-lane undivided rural arterial with a shared lane for northbound lefts and throughs at Vincent Avenue. There is a dedicated southbound right turn lane. Vincent Avenue has a single lane for the left and the right turn movements out. The Vincent Avenue approach to Burnt Store Road is currently under Stop control. There is a pedestrian crosswalk to cross Vincent Avenue and a sidewalk on the west side of Burnt Store Road which extends to the north.

- **Traffic Data Collection:** The approach and turning movement counts used in the analysis were collected in March 2024 (**Appendix A**). Based on the traffic count data, the Midday and the PM peak traffic volumes exceeded the AM peak traffic volumes, with the PM peak hour volumes being the highest volumes during the day. Therefore, the Midday and PM peak hour volumes were used for the ICE analyses. The counts data showed that there was only one pedestrian crossing in a period of eight hours.
- **Analysis Years:** The analysis years for this project include Existing Year (2024), Opening Year (2025), and Design Year (2045). Per the approved traffic analysis methodology, the ICE analysis Stage 1 was conducted for the design year.
- **Signal Warrant Analysis:** Crash data analysis for the recent five years (2019-2023) indicated a total of seventeen (17) crashes involving four (4) left turn crashes, eight (8) northbound rear-end crashes, and five (5) off-road crashes in the southbound direction at the intersection of Vincent Avenue at Burnt Store Road. Signal warrant analyses were conducted by using the opening year and the design year traffic volumes for the proposed geometry of two lanes per approach on the major street with speed exceeding 40 mph, and one lane per approach on the minor street following the recommendations of the Manual on Uniform Traffic Control Devices. The analyses were conducted with and without the right turn volumes included. The intersection did not meet Warrant 1A or 1B based on the opening year traffic volumes when the right turns on the minor street were excluded from the analysis. However, the intersection met Warrant 1B (Interruption of Continuous Traffic) when 50% of the right turns were included in the analysis for the opening year traffic volumes. The intersection also met the warrant 1B based on the design year traffic volumes with the right turn volumes excluded entirely from the minor street volumes (**Appendix B**).
- **Future Traffic Development:** The Burnt Store Road Project Traffic Analysis Report (PTAR) was approved in August 2022. The PTAR documented the development of project traffic for the Opening Year (2025) and Design Year (2045), based on March 2021 traffic counts which included both approach and turning movement counts. In addition, growth rates were derived from the District One Regional Planning Model (D1RPM). The approved annual growth rates were 8.2 percent for Burnt Store Road and 2.7 percent for intersecting cross streets including Vincent Avenue. In March 2024, at the request of Lee County, FDOT conducted new traffic counts for the Burnt Store Road at Vincent Avenue intersection, which included both 48-hour approach volume counts and 12-hour turning movement counts. The previously approved growth rates from the PTAR were then used in developing updated Opening Year (2025) and Design Year (2045) volumes for the Burnt Store Road at Vincent Avenue intersection ICE analysis based on the most recent traffic counts (**Appendix C**).
- **Environmental:** The state-owned and managed Babcock/Webb Wildlife Management Area consists of the Webb Tract, containing 65,758 acres, and the Yucca Pens Unit, consisting of 15,014 acres. The Yucca Pens Unit is located within southern Charlotte County and northwest Lee County. The property provides ecological diversity and managed habitat for both imperiled and common wildlife, and for providing the public with fishing and wildlife-based public outdoor recreational opportunities. Portions of the Burnt Store Road existing roadway right-of-way (ROW) are immediately adjacent to this conservation property, including an area just south of the Vincent Avenue intersection.

- Additionally, there are county-owned and managed conservation properties adjacent to Burnt Store Road, with one parcel located immediately east of Vincent Avenue. There are no public access points from Burnt Store Road.
- **ROW Constraints:** The existing ROW within the Lee County portion of the project consists of 200 feet while the small segment within Charlotte County is approximately 140 feet. The Preferred Alternative is centered within the existing ROW. An additional 0.2 acres of ROW from a single parcel is needed to construct the mainline roadway tie-in to the Charlotte County four-lane typical section.
- **Context Classification:** C2- Rural
- **Design Vehicle:** WB-62 FL (Tractor-trailer)

**Summary of ICE Analysis:** The ICE Stage 1 analysis was comprised of the Capacity Analysis for the Planning of Junctions (CAP-X) and the Safety Performance for Intersection Control Evaluation (SPICE). The ICE analyses were conducted for the existing conditions, Opening Year (2025) and the Design Year (2045). The list of viable intersection control options reduced to only three alternatives for the design year (**Appendix D**). The list of top three viable options for the design year is as shown below:

➤ CAP-X Results:

	Midday Peak	PM Peak
Top three alternatives	1. Signalized Restricted Crossing U-Turn (RCUT)	1. Signalized Restricted Crossing U-Turn (RCUT)
	2. Traffic Signal	2. Traffic Signal
	3. Continuous Green T (CGT)	3. Continuous Green T (CGT)

With PM peak being the critical peak for the intersection, the volume to capacity (V/C) ratios for the top three alternatives from the ICE analysis in the Design Year (2045) were as follows:

- Signalized Restricted Crossing U-Turn (RCUT): 0.73
- Traffic Signal: 0.75
- Continuous Green T (CGT): 0.75

➤ SPICE – Order of Crash Prediction Ranking:

Top three alternatives	1. Signalized RCUT
	2. Continuous Green T (CGT)
	3. Traffic Signal

**Concept Plans:** Concept plans showing the ROW were developed for the CGT, Signalized RCUT, a 2x1 Roundabout, and a Traffic Signal to help with the process of identifying best possible intersection control option (**Appendix E**).

**Summary and Recommendation:** The ICE analyses for the Design Year (2045) showed that a Signalized RCUT would perform the best, closely followed by Traffic Signal and CGT options at Vincent Avenue intersection. Although the 2x1 roundabout performed well based on SPICE’s SSI scoring criteria, it was not included in the top three viable control options since the CAP-X results indicated that it could experience capacity problems with V/C ratio of 1.03 for the northbound movements during the PM peak hour. Therefore, a SIDRA (Ver.9.1) analysis was

conducted to further investigate the operation of the roundabout in the design year. The results from SIDRA analysis for the roundabout did not indicate V/C ratios exceeding 1.0 for the northbound movements, however the southbound (north approach) movements showed V/C ratios exceeding 1.0 during the design year PM peak (**Appendix F**). Since it was also identified from the concept plan for the 2x1 roundabout that it will require additional ROW to construct encroaching into the conservation area, the roundabout option was eliminated from consideration.

Similarly, the Signalized RCUT option was not considered as it would require the left turns out of Vincent Avenue to turn right to go south and then make a U-turn to head back north. This option will also require additional ROW for accommodating the u-turning vehicles mixed with heavy vehicles, boat trailers, etc. Neither of the local maintaining agencies preferred this option.

Out of the remaining two viable options, a full Traffic Signal will subject all movements to a red phase, whereas a CGT will allow continuous flow for the northbound through traffic while providing signalized control for all the remaining movements. Even though both option can be viable, it should be noted that Charlotte County officials expressed preference for a traffic signal, whereas Lee County officials preferred a CGT. To further investigate the operational benefits between these two options, traffic signal operational analyses were conducted using Synchro (Ver.11) for the design year PM peak conditions (**Appendix F**). The analysis results showed that the average intersection delay for a CGT (LOS B) in the Design Year (PM Peak) will be 36% less compared to the delays with a Traffic Signal (LOS C). The SPICE analysis results also show that the CGT will have 15% less fatalities and injuries over the total project life compared to a Traffic Signal.

Although the CGT can be constructed without requiring additional ROW, this option will require a median modification to restrict the existing northbound left turn movement at the Wallaby Lane intersection located approximately 1,000 feet north of Vincent Avenue intersection (**Appendix D**). A CGT will also force the Wallaby Lane traffic to right-out only movements and require them to make U-turns at the median approximately 2,150 feet south of Wallaby Lane for going north on Burnt Store Road. However, the impact will be minimal considering overall operational benefits this option would provide.

Based on extensive coordination and consultation with the local maintaining agencies, the CGT option has been recommended as the preferred alternative for the subject intersection. This option will provide safe and efficient control for all vehicular movements, at the same time providing uninterrupted flow for the northbound through traffic. A free-flowing northbound movement will also be beneficial for emergency evacuations. Also, the CGT does not require any ROW from the conservation properties. Lee County recommended, and Charlotte County agreed, that the initial design plan will not include a pedestrian crossing across Burnt Store Road. However, Lee County will monitor pedestrian activity at this intersection as the area continues to develop and will install a pedestrian crossing when determined needed. The completed Stage 1 ICE forms are provided (**Appendix D**) for review and approval by the District Design Engineer (DDE) and District Traffic Operations Engineer (DTOE).

**Conclusion:** According to the 2024 FDOT ICE Manual, no further stages of ICE analyses are anticipated, as the Stage 1 analysis led to a single viable control strategy (CGT) for the intersection of Vincent Avenue at Burnt Store Road.

## **Appendix**

**Appendix A: Traffic Count Data**

**Appendix B: Signal Warrant Analysis**

**Appendix C: Traffic Projections**

**Appendix D: Intersection Control Evaluation (ICE) Forms**

**Appendix E: Concept Plans**

**Appendix F – Operational Analysis**



**Appendix A**  
**Traffic Count Data**

# Volume Count Report

Start Date: March 6, 2024      Start Time: 0:00      GPS: 26.767669  
 Stop Date: March 7, 2024      Stop Time: 0:00      -82.038293  
 City: Cape Coral      County: Lee  
 Location: Burnt Store Rd between Vincent Ave & Islamorada Blvd

## Northbound Volume

**Wednesday, March 6, 2024**

End Time	00	01	02	03	04	05	06	07	08	09	10	11
15	4	2	2	3	15	28	101	198	165	168	174	188
30	8	2	10	10	15	68	103	198	191	158	181	164
45	3	4	7	12	22	70	137	202	191	163	166	157
00	3	4	7	7	40	94	177	180	182	151	176	149
<b>Hr Total</b>	<b>18</b>	<b>12</b>	<b>26</b>	<b>32</b>	<b>92</b>	<b>260</b>	<b>518</b>	<b>778</b>	<b>729</b>	<b>640</b>	<b>697</b>	<b>658</b>

End Time	12	13	14	15	16	17	18	19	20	21	22	23
15	153	135	124	131	108	125	102	45	41	33	16	7
30	165	136	117	140	122	102	80	50	36	31	11	3
45	148	154	103	118	120	125	67	40	31	34	14	4
00	137	123	128	139	130	70	66	50	37	27	12	7
<b>Hr Total</b>	<b>603</b>	<b>548</b>	<b>472</b>	<b>528</b>	<b>480</b>	<b>422</b>	<b>315</b>	<b>185</b>	<b>145</b>	<b>125</b>	<b>53</b>	<b>21</b>

24 Hour Total: 8,357  
 AM Peak Hour begins: 7:00      AM Peak Volume: 778      AM Peak Hour Factor: 0.96  
 PM Peak Hour begins: 12:00      PM Peak Volume: 603      PM Peak Hour Factor: 0.91

## Southbound Volume

**Wednesday, March 6, 2024**

End Time	00	01	02	03	04	05	06	07	08	09	10	11
15	13	3	5	4	3	12	33	76	100	106	122	140
30	4	5	3	1	5	13	51	96	108	128	133	108
45	9	10	13	4	9	18	78	107	91	125	147	137
00	10	5	5	12	14	22	65	100	99	120	140	124
<b>Hr Total</b>	<b>36</b>	<b>23</b>	<b>26</b>	<b>21</b>	<b>31</b>	<b>65</b>	<b>227</b>	<b>379</b>	<b>398</b>	<b>479</b>	<b>542</b>	<b>509</b>

End Time	12	13	14	15	16	17	18	19	20	21	22	23
15	175	148	166	182	207	197	168	120	73	58	44	22
30	156	146	163	207	222	216	137	92	73	41	35	20
45	149	132	185	210	247	209	127	98	57	34	17	23
00	157	181	180	198	214	152	114	85	51	51	16	18
<b>Hr Total</b>	<b>637</b>	<b>607</b>	<b>694</b>	<b>797</b>	<b>890</b>	<b>774</b>	<b>546</b>	<b>395</b>	<b>254</b>	<b>184</b>	<b>112</b>	<b>83</b>

24 Hour Total: 8,709  
 AM Peak Hour begins: 10:15      AM Peak Volume: 560      AM Peak Hour Factor: 0.95  
 PM Peak Hour begins: 16:00      PM Peak Volume: 890      PM Peak Hour Factor: 0.90

## Total Volume

**Wednesday, March 6, 2024**

End Time	00	01	02	03	04	05	06	07	08	09	10	11
15	17	5	7	7	18	40	134	274	265	274	296	328
30	12	7	13	11	20	81	154	294	299	286	314	272
45	12	14	20	16	31	88	215	309	282	288	313	294
00	13	9	12	19	54	116	242	280	281	271	316	273
<b>Hr Total</b>	<b>54</b>	<b>35</b>	<b>52</b>	<b>53</b>	<b>123</b>	<b>325</b>	<b>745</b>	<b>1,157</b>	<b>1,127</b>	<b>1,119</b>	<b>1,239</b>	<b>1,167</b>

End Time	12	13	14	15	16	17	18	19	20	21	22	23
15	328	283	290	313	315	322	270	165	114	91	60	29
30	321	282	280	347	344	318	217	142	109	72	46	23
45	297	286	288	328	367	334	194	138	88	68	31	27
00	294	304	308	337	344	222	180	135	88	78	28	25
<b>Hr Total</b>	<b>1,240</b>	<b>1,155</b>	<b>1,166</b>	<b>1,325</b>	<b>1,370</b>	<b>1,196</b>	<b>861</b>	<b>580</b>	<b>399</b>	<b>309</b>	<b>165</b>	<b>104</b>

24 Hour Total: 17,066  
 AM Peak Hour begins: 10:15      AM Peak Volume: 1,271      AM Peak Hour Factor: 0.97  
 PM Peak Hour begins: 16:15      PM Peak Volume: 1,377      PM Peak Hour Factor: 0.94

# Volume Count Report

Start Date: March 7, 2024	Start Time: 0:00	GPS: 26.767669
Stop Date: March 8, 2024	Stop Time: 0:00	-82.038293
City: Cape Coral	County: Lee	
Location: Burnt Store Rd between Vincent Ave & Islamorada Blvd		

## Northbound Volume

**Thursday, March 7, 2024**

End Time	00	01	02	03	04	05	06	07	08	09	10	11
15	4	8	6	13	16	46	108	184	185	172	166	159
30	7	5	6	6	24	79	140	209	172	183	171	193
45	2	4	10	17	42	68	139	216	222	175	198	182
00	6	1	10	14	31	94	155	175	137	174	193	191
<b>Hr Total</b>	<b>19</b>	<b>18</b>	<b>32</b>	<b>50</b>	<b>113</b>	<b>287</b>	<b>542</b>	<b>784</b>	<b>716</b>	<b>704</b>	<b>728</b>	<b>725</b>

End Time	12	13	14	15	16	17	18	19	20	21	22	23
15	173	158	143	115	144	134	87	54	55	34	26	9
30	145	142	154	144	154	137	81	71	49	44	28	12
45	164	132	147	114	140	118	81	52	44	45	21	14
00	168	164	143	113	125	111	69	51	41	26	16	14
<b>Hr Total</b>	<b>650</b>	<b>596</b>	<b>587</b>	<b>486</b>	<b>563</b>	<b>500</b>	<b>318</b>	<b>228</b>	<b>189</b>	<b>149</b>	<b>91</b>	<b>49</b>

24 Hour Total:	9,124	AM Peak Volume:	785	AM Peak Hour Factor:	0.91
AM Peak Hour begins:	7:15	PM Peak Volume:	650	PM Peak Hour Factor:	0.94
PM Peak Hour begins:	12:00				

## Southbound Volume

**Thursday, March 7, 2024**

End Time	00	01	02	03	04	05	06	07	08	09	10	11
15	16	8	8	5	8	15	46	75	105	96	123	173
30	16	9	7	1	1	23	62	75	99	116	132	149
45	9	11	3	7	7	34	76	101	105	115	160	145
00	1	5	6	5	10	43	85	110	107	120	135	150
<b>Hr Total</b>	<b>42</b>	<b>33</b>	<b>24</b>	<b>18</b>	<b>26</b>	<b>115</b>	<b>269</b>	<b>361</b>	<b>416</b>	<b>447</b>	<b>550</b>	<b>617</b>

End Time	12	13	14	15	16	17	18	19	20	21	22	23
15	144	161	172	183	211	235	204	141	91	63	40	36
30	202	179	176	189	251	227	143	93	79	54	42	55
45	166	172	166	212	225	250	168	112	84	67	51	29
00	168	160	178	223	227	201	149	92	73	59	41	19
<b>Hr Total</b>	<b>680</b>	<b>672</b>	<b>692</b>	<b>807</b>	<b>914</b>	<b>913</b>	<b>664</b>	<b>438</b>	<b>327</b>	<b>243</b>	<b>174</b>	<b>139</b>

24 Hour Total:	9,581	AM Peak Volume:	617	AM Peak Hour Factor:	0.89
AM Peak Hour begins:	10:30	PM Peak Volume:	939	PM Peak Hour Factor:	0.94
PM Peak Hour begins:	16:45				

## Total Volume

**Thursday, March 7, 2024**

End Time	00	01	02	03	04	05	06	07	08	09	10	11
15	20	16	14	18	24	61	154	259	290	268	289	332
30	23	14	13	7	25	102	202	284	271	299	303	342
45	11	15	13	24	49	102	215	317	327	290	358	327
00	7	6	16	19	41	137	240	285	244	294	328	341
<b>Hr Total</b>	<b>61</b>	<b>51</b>	<b>56</b>	<b>68</b>	<b>139</b>	<b>402</b>	<b>811</b>	<b>1,145</b>	<b>1,132</b>	<b>1,151</b>	<b>1,278</b>	<b>1,342</b>

End Time	12	13	14	15	16	17	18	19	20	21	22	23
15	317	319	315	298	355	369	291	195	146	97	66	45
30	347	321	330	333	405	364	224	164	128	98	70	67
45	330	304	313	326	365	368	249	164	128	112	72	43
00	336	324	321	336	352	312	218	143	114	85	57	33
<b>Hr Total</b>	<b>1,330</b>	<b>1,268</b>	<b>1,279</b>	<b>1,293</b>	<b>1,477</b>	<b>1,413</b>	<b>982</b>	<b>666</b>	<b>516</b>	<b>392</b>	<b>265</b>	<b>188</b>

24 Hour Total:	18,705	AM Peak Volume:	1,360	AM Peak Hour Factor:	0.95
AM Peak Hour begins:	10:30	PM Peak Volume:	1,491	PM Peak Hour Factor:	0.92
PM Peak Hour begins:	16:15				

# Volume Count Report

## 2-Day Average

Start Date: March 6, 2024	Start Time: 0:00	GPS: 26.767669
Stop Date: March 8, 2024	Stop Time: 0:00	-82.038293
City: Cape Coral	County: Lee	
Location: Burnt Store Rd between Vincent Ave & Islamorada Blvd		

### Northbound Volume

#### 2-Day Average

End Time	00	01	02	03	04	05	06	07	08	09	10	11
15	4	5	4	8	16	37	105	191	175	170	170	174
30	8	4	8	8	20	74	122	204	182	171	176	179
45	3	4	9	15	32	69	138	209	207	169	182	170
00	5	3	9	11	36	94	166	178	160	163	185	170
<b>Hr Total</b>	<b>19</b>	<b>15</b>	<b>29</b>	<b>41</b>	<b>103</b>	<b>274</b>	<b>530</b>	<b>781</b>	<b>723</b>	<b>672</b>	<b>713</b>	<b>692</b>

End Time	12	13	14	15	16	17	18	19	20	21	22	23
15	163	147	134	123	126	130	95	50	48	34	21	8
30	155	139	136	142	138	120	81	61	43	38	20	8
45	156	143	125	116	130	122	74	46	38	40	18	9
00	153	144	136	126	128	91	68	51	39	27	14	11
<b>Hr Total</b>	<b>627</b>	<b>572</b>	<b>530</b>	<b>507</b>	<b>522</b>	<b>461</b>	<b>317</b>	<b>207</b>	<b>167</b>	<b>137</b>	<b>72</b>	<b>35</b>

24 Hour Total:	8,741			
AM Peak Hour begins:	7:00	AM Peak Volume:	781	AM Peak Hour Factor: 0.93
PM Peak Hour begins:	12:00	PM Peak Volume:	627	PM Peak Hour Factor: 0.96

### Southbound Volume

#### 2-Day Average

End Time	00	01	02	03	04	05	06	07	08	09	10	11
15	15	6	7	5	6	14	40	76	103	101	123	157
30	10	7	5	1	3	18	57	86	104	122	133	129
45	9	11	8	6	8	26	77	104	98	120	154	141
00	6	5	6	9	12	33	75	105	103	120	138	137
<b>Hr Total</b>	<b>39</b>	<b>28</b>	<b>25</b>	<b>20</b>	<b>29</b>	<b>90</b>	<b>248</b>	<b>370</b>	<b>407</b>	<b>463</b>	<b>546</b>	<b>563</b>

End Time	12	13	14	15	16	17	18	19	20	21	22	23
15	160	155	169	183	209	216	186	131	82	61	42	29
30	179	163	170	198	237	222	140	93	76	48	39	38
45	158	152	176	211	236	230	148	105	71	51	34	26
00	163	171	179	211	221	177	132	89	62	55	29	19
<b>Hr Total</b>	<b>659</b>	<b>640</b>	<b>693</b>	<b>802</b>	<b>902</b>	<b>844</b>	<b>605</b>	<b>417</b>	<b>291</b>	<b>214</b>	<b>143</b>	<b>111</b>

24 Hour Total:	9,145			
AM Peak Hour begins:	10:15	AM Peak Volume:	580	AM Peak Hour Factor: 0.93
PM Peak Hour begins:	16:15	PM Peak Volume:	909	PM Peak Hour Factor: 0.96

### Total Volume

#### 2-Day Average

End Time	00	01	02	03	04	05	06	07	08	09	10	11
15	19	11	11	13	21	51	144	267	278	271	293	330
30	18	11	13	9	23	92	178	289	285	293	309	307
45	12	15	17	20	40	95	215	313	305	289	336	311
00	10	8	14	19	48	127	241	283	263	283	322	307
<b>Hr Total</b>	<b>58</b>	<b>43</b>	<b>54</b>	<b>61</b>	<b>131</b>	<b>364</b>	<b>778</b>	<b>1,151</b>	<b>1,130</b>	<b>1,135</b>	<b>1,259</b>	<b>1,255</b>

End Time	12	13	14	15	16	17	18	19	20	21	22	23
15	323	301	303	306	335	346	281	180	130	94	63	37
30	334	302	305	340	375	341	221	153	119	85	58	45
45	314	295	301	327	366	351	222	151	108	90	52	35
00	315	314	315	337	348	267	199	139	101	82	43	29
<b>Hr Total</b>	<b>1,285</b>	<b>1,212</b>	<b>1,223</b>	<b>1,309</b>	<b>1,424</b>	<b>1,305</b>	<b>922</b>	<b>623</b>	<b>458</b>	<b>351</b>	<b>215</b>	<b>146</b>

24 Hour Total:	17,886			
AM Peak Hour begins:	10:15	AM Peak Volume:	1,296	AM Peak Hour Factor: 0.97
PM Peak Hour begins:	16:15	PM Peak Volume:	1,434	PM Peak Hour Factor: 0.96

# Volume Count Report

Start Date: March 6, 2024  
 Stop Date: March 7, 2024  
 City: Cape Coral  
 Location: Vincent Ave west of Burnt Store Rd

Start Time: 0:00  
 Stop Time: 0:00  
 County: Lee

GPS: 26.770441  
 -82.039228

## Eastbound Volume

**Wednesday, March 6, 2024**

End Time	00	01	02	03	04	05	06	07	08	09	10	11
15	0	0	0	0	1	1	8	6	12	23	21	20
30	0	0	0	0	1	1	4	6	9	23	28	9
45	0	0	0	0	1	2	6	12	14	22	30	21
00	0	0	0	1	0	2	9	14	12	20	29	23
<b>Hr Total</b>	<b>0</b>	<b>0</b>	<b>0</b>	<b>1</b>	<b>3</b>	<b>6</b>	<b>27</b>	<b>38</b>	<b>47</b>	<b>88</b>	<b>108</b>	<b>73</b>

End Time	12	13	14	15	16	17	18	19	20	21	22	23
15	34	24	19	14	20	26	8	4	12	6	0	0
30	30	18	25	12	13	12	7	6	4	2	0	0
45	22	18	24	12	24	16	9	3	8	0	2	0
00	29	22	21	20	20	12	10	14	6	0	0	0
<b>Hr Total</b>	<b>115</b>	<b>82</b>	<b>89</b>	<b>58</b>	<b>77</b>	<b>66</b>	<b>34</b>	<b>27</b>	<b>30</b>	<b>8</b>	<b>2</b>	<b>0</b>

24 Hour Total: 979  
 AM Peak Hour begins: 10:00 AM Peak Volume: 108 AM Peak Hour Factor: 0.90  
 PM Peak Hour begins: 12:00 PM Peak Volume: 115 PM Peak Hour Factor: 0.85

## Westbound Volume

**Wednesday, March 6, 2024**

End Time	00	01	02	03	04	05	06	07	08	09	10	11
15	0	0	0	1	0	0	2	6	14	20	33	27
30	0	0	0	0	0	1	1	14	15	15	24	23
45	0	0	0	0	0	0	3	22	22	30	29	31
00	0	0	0	1	1	0	4	20	18	27	20	29
<b>Hr Total</b>	<b>0</b>	<b>0</b>	<b>0</b>	<b>2</b>	<b>1</b>	<b>1</b>	<b>10</b>	<b>62</b>	<b>69</b>	<b>92</b>	<b>106</b>	<b>110</b>

End Time	12	13	14	15	16	17	18	19	20	21	22	23
15	29	31	33	34	28	23	10	10	10	7	4	0
30	23	30	22	24	30	17	11	11	7	1	0	1
45	34	32	27	30	36	18	12	13	5	4	1	0
00	32	26	31	33	32	17	10	10	5	0	0	0
<b>Hr Total</b>	<b>118</b>	<b>119</b>	<b>113</b>	<b>121</b>	<b>126</b>	<b>75</b>	<b>43</b>	<b>44</b>	<b>27</b>	<b>12</b>	<b>5</b>	<b>1</b>

24 Hour Total: 1,257  
 AM Peak Hour begins: 9:30 AM Peak Volume: 114 AM Peak Hour Factor: 0.86  
 PM Peak Hour begins: 12:30 PM Peak Volume: 127 PM Peak Hour Factor: 0.93

## Total Volume

**Wednesday, March 6, 2024**

End Time	00	01	02	03	04	05	06	07	08	09	10	11
15	0	0	0	1	1	1	10	12	26	43	54	47
30	0	0	0	0	1	2	5	20	24	38	52	32
45	0	0	0	0	1	2	9	34	36	52	59	52
00	0	0	0	2	1	2	13	34	30	47	49	52
<b>Hr Total</b>	<b>0</b>	<b>0</b>	<b>0</b>	<b>3</b>	<b>4</b>	<b>7</b>	<b>37</b>	<b>100</b>	<b>116</b>	<b>180</b>	<b>214</b>	<b>183</b>

End Time	12	13	14	15	16	17	18	19	20	21	22	23
15	63	55	52	48	48	49	18	14	22	13	4	0
30	53	48	47	36	43	29	18	17	11	3	0	1
45	56	50	51	42	60	34	21	16	13	4	3	0
00	61	48	52	53	52	29	20	24	11	0	0	0
<b>Hr Total</b>	<b>233</b>	<b>201</b>	<b>202</b>	<b>179</b>	<b>203</b>	<b>141</b>	<b>77</b>	<b>71</b>	<b>57</b>	<b>20</b>	<b>7</b>	<b>1</b>

24 Hour Total: 2,236  
 AM Peak Hour begins: 10:00 AM Peak Volume: 214 AM Peak Hour Factor: 0.91  
 PM Peak Hour begins: 12:00 PM Peak Volume: 233 PM Peak Hour Factor: 0.92

# Volume Count Report

Start Date: March 7, 2024  
 Stop Date: March 8, 2024  
 City: Cape Coral  
 Location: Vincent Ave west of Burnt Store Rd

Start Time: 0:00  
 Stop Time: 0:00  
 County: Lee

GPS: 26.770441  
 -82.039228

## Eastbound Volume

**Thursday, March 7, 2024**

End Time	00	01	02	03	04	05	06	07	08	09	10	11
15	0	0	1	0	1	2	6	5	11	13	19	30
30	0	0	0	0	3	2	3	10	19	25	24	28
45	0	0	0	0	1	2	3	10	16	13	27	30
00	0	0	1	0	0	4	10	8	22	18	29	12
<b>Hr Total</b>	<b>0</b>	<b>0</b>	<b>2</b>	<b>0</b>	<b>5</b>	<b>10</b>	<b>22</b>	<b>33</b>	<b>68</b>	<b>69</b>	<b>99</b>	<b>100</b>

End Time	12	13	14	15	16	17	18	19	20	21	22	23
15	22	25	28	25	20	20	21	10	14	3	2	0
30	16	30	21	19	10	19	11	5	11	3	1	0
45	25	23	17	17	12	12	18	7	13	0	0	0
00	27	23	26	30	22	7	12	20	7	3	0	0
<b>Hr Total</b>	<b>90</b>	<b>101</b>	<b>92</b>	<b>91</b>	<b>64</b>	<b>58</b>	<b>62</b>	<b>42</b>	<b>45</b>	<b>9</b>	<b>3</b>	<b>0</b>

24 Hour Total: 1,065  
 AM Peak Hour begins: 10:45 AM Peak Volume: 117 AM Peak Hour Factor: 0.98  
 PM Peak Hour begins: 12:30 PM Peak Volume: 107 PM Peak Hour Factor: 0.89

## Westbound Volume

**Thursday, March 7, 2024**

End Time	00	01	02	03	04	05	06	07	08	09	10	11
15	0	0	0	1	0	0	1	8	15	24	28	33
30	1	0	0	0	0	0	2	12	14	28	33	38
45	0	0	0	0	1	1	2	18	22	22	34	36
00	2	0	0	0	0	0	7	15	19	20	26	37
<b>Hr Total</b>	<b>3</b>	<b>0</b>	<b>0</b>	<b>1</b>	<b>1</b>	<b>1</b>	<b>12</b>	<b>53</b>	<b>70</b>	<b>94</b>	<b>121</b>	<b>144</b>

End Time	12	13	14	15	16	17	18	19	20	21	22	23
15	29	19	23	25	25	31	23	9	8	4	0	1
30	20	30	30	45	25	21	11	5	9	4	3	3
45	28	31	34	30	35	28	14	13	6	5	3	0
00	25	24	32	33	41	21	9	8	6	2	1	0
<b>Hr Total</b>	<b>102</b>	<b>104</b>	<b>119</b>	<b>133</b>	<b>126</b>	<b>101</b>	<b>57</b>	<b>35</b>	<b>29</b>	<b>15</b>	<b>7</b>	<b>4</b>

24 Hour Total: 1,332  
 AM Peak Hour begins: 11:00 AM Peak Volume: 144 AM Peak Hour Factor: 0.95  
 PM Peak Hour begins: 14:30 PM Peak Volume: 136 PM Peak Hour Factor: 0.76

## Total Volume

**Thursday, March 7, 2024**

End Time	00	01	02	03	04	05	06	07	08	09	10	11
15	0	0	1	1	1	2	7	13	26	37	47	63
30	1	0	0	0	3	2	5	22	33	53	57	66
45	0	0	0	0	2	3	5	28	38	35	61	66
00	2	0	1	0	0	4	17	23	41	38	55	49
<b>Hr Total</b>	<b>3</b>	<b>0</b>	<b>2</b>	<b>1</b>	<b>6</b>	<b>11</b>	<b>34</b>	<b>86</b>	<b>138</b>	<b>163</b>	<b>220</b>	<b>244</b>

End Time	12	13	14	15	16	17	18	19	20	21	22	23
15	51	44	51	50	45	51	44	19	22	7	2	1
30	36	60	51	64	35	40	22	10	20	7	4	3
45	53	54	51	47	47	40	32	20	19	5	3	0
00	52	47	58	63	63	28	21	28	13	5	1	0
<b>Hr Total</b>	<b>192</b>	<b>205</b>	<b>211</b>	<b>224</b>	<b>190</b>	<b>159</b>	<b>119</b>	<b>77</b>	<b>74</b>	<b>24</b>	<b>10</b>	<b>4</b>

24 Hour Total: 2,397  
 AM Peak Hour begins: 10:45 AM Peak Volume: 250 AM Peak Hour Factor: 0.95  
 PM Peak Hour begins: 15:00 PM Peak Volume: 224 PM Peak Hour Factor: 0.88

# Volume Count Report

## 2-Day Average

Start Date: March 6, 2024	Start Time: 0:00	GPS: 26.770441
Stop Date: March 8, 2024	Stop Time: 0:00	-82.039228
City: Cape Coral	County: Lee	
Location: Vincent Ave west of Burnt Store Rd		

### Eastbound Volume

#### 2-Day Average

End Time	00	01	02	03	04	05	06	07	08	09	10	11
15	0	0	1	0	1	2	7	6	12	18	20	25
30	0	0	0	0	2	2	4	8	14	24	26	19
45	0	0	0	0	1	2	5	11	15	18	29	26
00	0	0	1	1	0	3	10	11	17	19	29	18
<b>Hr Total</b>	<b>0</b>	<b>0</b>	<b>1</b>	<b>1</b>	<b>4</b>	<b>8</b>	<b>25</b>	<b>36</b>	<b>58</b>	<b>79</b>	<b>104</b>	<b>87</b>

End Time	12	13	14	15	16	17	18	19	20	21	22	23
15	28	25	24	20	20	23	15	7	13	5	1	0
30	23	24	23	16	12	16	9	6	8	3	1	0
45	24	21	21	15	18	14	14	5	11	0	1	0
00	28	23	24	25	21	10	11	17	7	2	0	0
<b>Hr Total</b>	<b>103</b>	<b>92</b>	<b>91</b>	<b>75</b>	<b>71</b>	<b>62</b>	<b>48</b>	<b>35</b>	<b>38</b>	<b>9</b>	<b>3</b>	<b>0</b>

24 Hour Total:	1,022				
AM Peak Hour begins:	10:15	AM Peak Volume:	109	AM Peak Hour Factor:	0.94
PM Peak Hour begins:	12:00	PM Peak Volume:	103	PM Peak Hour Factor:	0.92

### Westbound Volume

#### 2-Day Average

End Time	00	01	02	03	04	05	06	07	08	09	10	11
15	0	0	0	1	0	0	2	7	15	22	31	30
30	1	0	0	0	0	1	2	13	15	22	29	31
45	0	0	0	0	1	1	3	20	22	26	32	34
00	1	0	0	1	1	0	6	18	19	24	23	33
<b>Hr Total</b>	<b>2</b>	<b>0</b>	<b>0</b>	<b>2</b>	<b>1</b>	<b>1</b>	<b>11</b>	<b>58</b>	<b>70</b>	<b>93</b>	<b>114</b>	<b>127</b>

End Time	12	13	14	15	16	17	18	19	20	21	22	23
15	29	25	28	30	27	27	17	10	9	6	2	1
30	22	30	26	35	28	19	11	8	8	3	2	2
45	31	32	31	30	36	23	13	13	6	5	2	0
00	29	25	32	33	37	19	10	9	6	1	1	0
<b>Hr Total</b>	<b>110</b>	<b>112</b>	<b>116</b>	<b>127</b>	<b>126</b>	<b>88</b>	<b>50</b>	<b>40</b>	<b>28</b>	<b>14</b>	<b>6</b>	<b>3</b>

24 Hour Total:	1,295				
AM Peak Hour begins:	11:00	AM Peak Volume:	127	AM Peak Hour Factor:	0.95
PM Peak Hour begins:	15:00	PM Peak Volume:	127	PM Peak Hour Factor:	0.92

### Total Volume

#### 2-Day Average

End Time	00	01	02	03	04	05	06	07	08	09	10	11
15	0	0	1	1	1	2	9	13	26	40	51	55
30	1	0	0	0	2	2	5	21	29	46	55	49
45	0	0	0	0	2	3	7	31	37	44	60	59
00	1	0	1	1	1	3	15	29	36	43	52	51
<b>Hr Total</b>	<b>2</b>	<b>0</b>	<b>1</b>	<b>2</b>	<b>5</b>	<b>9</b>	<b>36</b>	<b>93</b>	<b>127</b>	<b>172</b>	<b>217</b>	<b>214</b>

End Time	12	13	14	15	16	17	18	19	20	21	22	23
15	57	50	52	49	47	50	31	17	22	10	3	1
30	45	54	49	50	39	35	20	14	16	5	2	2
45	55	52	51	45	54	37	27	18	16	5	3	0
00	57	48	55	58	58	29	21	26	12	3	1	0
<b>Hr Total</b>	<b>213</b>	<b>203</b>	<b>207</b>	<b>202</b>	<b>197</b>	<b>150</b>	<b>98</b>	<b>74</b>	<b>66</b>	<b>22</b>	<b>9</b>	<b>3</b>

24 Hour Total:	2,317				
AM Peak Hour begins:	10:15	AM Peak Volume:	222	AM Peak Hour Factor:	0.92
PM Peak Hour begins:	12:30	PM Peak Volume:	215	PM Peak Hour Factor:	0.95

## Intersection Turning Movement Count

City/County: Cape Coral/Lee  
 Weather: Light Rain 3:07-3:20pm  
 Comments:

File Name : BurntStoreRd&Vincent  
 Site Code : 19033  
 Start Date : 3/6/2024  
 Page No : 1

Groups Printed- Passenger Vehicles - Heavy Vehicle - UTurns

Start Time	BURNT STORE ROAD Southbound				BURNT STORE ROAD Northbound				VINCENT AVENUE Eastbound				Int. Total
	Left	Thru	Right	App. Total	Left	Thru	Right	App. Total	Left	Thru	Right	App. Total	
07:00 AM	0	69	3	72	2	196	0	198	4	0	3	7	277
07:15 AM	0	86	9	95	5	172	0	177	3	0	3	6	278
07:30 AM	0	96	10	106	9	187	0	196	5	0	4	9	311
07:45 AM	0	91	10	101	10	160	0	170	15	0	3	18	289
Total	0	342	32	374	26	715	0	741	27	0	13	40	1155
08:00 AM	0	96	11	107	2	154	0	156	10	0	2	12	275
08:15 AM	0	86	14	100	1	191	0	192	4	0	5	9	301
08:30 AM	0	81	14	95	7	165	0	172	7	0	6	13	280
08:45 AM	0	81	12	93	4	170	0	174	7	0	5	12	279
Total	0	344	51	395	14	680	0	694	28	0	18	46	1135
09:00 AM	0	88	14	102	6	145	0	151	19	0	3	22	275
09:15 AM	0	101	15	116	1	143	0	144	17	0	7	24	284
09:30 AM	0	99	19	118	10	138	0	148	15	0	7	22	288
09:45 AM	0	103	15	118	11	140	0	151	13	0	4	17	286
Total	0	391	63	454	28	566	0	594	64	0	21	85	1133
10:00 AM	0	101	26	127	6	150	0	156	21	0	4	25	308
10:15 AM	0	109	18	127	6	167	0	173	13	0	7	20	320
10:30 AM	0	134	15	149	12	148	0	160	22	0	10	32	341
10:45 AM	0	113	15	128	5	157	0	162	21	0	8	29	319
Total	0	457	74	531	29	622	0	651	77	0	29	106	1288
11:00 AM	0	116	18	134	8	168	0	176	11	0	9	20	330
11:15 AM	0	98	18	116	4	147	0	151	5	0	6	11	278
11:30 AM	0	118	24	142	6	138	0	144	15	0	7	22	308
11:45 AM	0	118	24	142	8	125	0	133	18	0	5	23	298
Total	0	450	84	534	26	578	0	604	49	0	27	76	1214
12:00 PM	1	144	21	166	8	140	0	148	21	0	10	31	345
12:15 PM	0	136	21	157	4	147	0	151	27	0	8	35	343
12:30 PM	0	137	27	164	8	135	0	143	14	0	6	20	327
12:45 PM	0	137	23	160	7	133	0	140	17	0	12	29	329
Total	1	554	92	647	27	555	0	582	79	0	36	115	1344
01:00 PM	0	119	24	143	6	117	0	123	15	0	10	25	291
01:15 PM	0	127	28	155	2	132	0	134	15	0	3	18	307
01:30 PM	0	124	28	152	3	147	0	150	12	0	3	15	317
01:45 PM	0	162	25	187	3	110	0	113	17	0	9	26	326
Total	0	532	105	637	14	506	0	520	59	0	25	84	1241
02:00 PM	0	132	27	159	5	115	0	120	13	0	6	19	298
02:15 PM	0	144	19	163	3	101	0	104	15	0	12	27	294
02:30 PM	0	155	21	176	5	99	0	104	15	0	6	21	301
02:45 PM	0	161	25	186	6	117	0	123	15	0	5	20	329
Total	0	592	92	684	19	432	0	451	58	0	29	87	1222
03:00 PM	0	160	23	183	8	125	0	133	13	0	4	17	333
03:15 PM	0	193	17	210	7	124	0	131	7	0	5	12	353
03:30 PM	0	184	29	213	1	131	0	132	7	0	3	10	355
03:45 PM	0	187	23	210	9	117	0	126	12	0	9	21	357
Total	0	724	92	816	25	497	0	522	39	0	21	60	1398
04:00 PM	0	191	23	214	4	111	0	115	14	0	6	20	349
04:15 PM	0	207	27	234	3	115	0	118	9	0	5	14	366
04:30 PM	0	213	29	242	6	112	0	118	13	0	8	21	381
04:45 PM	0	202	25	227	7	119	0	126	13	0	6	19	372
Total	0	813	104	917	20	457	0	477	49	0	25	74	1468





## Intersection Turning Movement Count

City/County: Cape Coral/Lee  
 Weather: Light Rain 3:07-3:20pm  
 Comments:

File Name : BurntStoreRd&Vincen  
 Site Code : 19033  
 Start Date : 3/6/2024  
 Page No : 1

### Groups Printed- Passenger Vehicles

Start Time	BURNT STORE ROAD Southbound				BURNT STORE ROAD Northbound				VINCENT AVENUE Eastbound				Int. Total
	Left	Thru	Right	App. Total	Left	Thru	Right	App. Total	Left	Thru	Right	App. Total	
07:00 AM	0	62	3	65	2	178	0	180	4	0	3	7	252
07:15 AM	0	77	8	85	5	160	0	165	3	0	3	6	256
07:30 AM	0	93	9	102	7	180	0	187	5	0	3	8	297
07:45 AM	0	91	10	101	9	149	0	158	15	0	3	18	277
Total	0	323	30	353	23	667	0	690	27	0	12	39	1082
08:00 AM	0	84	10	94	2	148	0	150	10	0	2	12	256
08:15 AM	0	73	14	87	1	175	0	176	4	0	5	9	272
08:30 AM	0	74	11	85	6	154	0	160	7	0	6	13	258
08:45 AM	0	69	10	79	3	147	0	150	7	0	5	12	241
Total	0	300	45	345	12	624	0	636	28	0	18	46	1027
09:00 AM	0	71	12	83	5	134	0	139	18	0	3	21	243
09:15 AM	0	82	10	92	1	124	0	125	16	0	5	21	238
09:30 AM	0	79	18	97	8	130	0	138	13	0	5	18	253
09:45 AM	0	86	15	101	10	123	0	133	13	0	4	17	251
Total	0	318	55	373	24	511	0	535	60	0	17	77	985
10:00 AM	0	88	24	112	6	121	0	127	19	0	3	22	261
10:15 AM	0	98	17	115	5	146	0	151	12	0	7	19	285
10:30 AM	0	122	15	137	11	135	0	146	21	0	8	29	312
10:45 AM	0	96	15	111	5	137	0	142	21	0	8	29	282
Total	0	404	71	475	27	539	0	566	73	0	26	99	1140
11:00 AM	0	102	17	119	7	150	0	157	10	0	7	17	293
11:15 AM	0	91	17	108	4	133	0	137	5	0	6	11	256
11:30 AM	0	105	23	128	5	127	0	132	15	0	5	20	280
11:45 AM	0	108	23	131	6	114	0	120	18	0	5	23	274
Total	0	406	80	486	22	524	0	546	48	0	23	71	1103
12:00 PM	0	131	19	150	8	125	0	133	19	0	10	29	312
12:15 PM	0	125	21	146	4	131	0	135	24	0	8	32	313
12:30 PM	0	126	26	152	8	123	0	131	14	0	6	20	303
12:45 PM	0	123	22	145	7	127	0	134	16	0	12	28	307
Total	0	505	88	593	27	506	0	533	73	0	36	109	1235
01:00 PM	0	103	24	127	6	108	0	114	15	0	10	25	266
01:15 PM	0	110	27	137	2	121	0	123	15	0	3	18	278
01:30 PM	0	117	27	144	3	128	0	131	10	0	3	13	288
01:45 PM	0	142	25	167	3	100	0	103	16	0	9	25	295
Total	0	472	103	575	14	457	0	471	56	0	25	81	1127
02:00 PM	0	122	25	147	4	106	0	110	13	0	6	19	276
02:15 PM	0	129	18	147	3	92	0	95	14	0	10	24	266
02:30 PM	0	139	21	160	5	88	0	93	14	0	6	20	273
02:45 PM	0	150	25	175	6	109	0	115	14	0	5	19	309
Total	0	540	89	629	18	395	0	413	55	0	27	82	1124
03:00 PM	0	147	23	170	7	119	0	126	13	0	4	17	313
03:15 PM	0	180	15	195	5	119	0	124	6	0	5	11	330
03:30 PM	0	173	26	199	1	128	0	129	7	0	3	10	338
03:45 PM	0	179	23	202	9	112	0	121	11	0	8	19	342
Total	0	679	87	766	22	478	0	500	37	0	20	57	1323
04:00 PM	0	180	23	203	4	109	0	113	13	0	6	19	335
04:15 PM	0	195	27	222	3	111	0	114	8	0	5	13	349
04:30 PM	0	198	29	227	6	107	0	113	13	0	7	20	360
04:45 PM	0	196	25	221	7	117	0	124	13	0	6	19	364
Total	0	769	104	873	20	444	0	464	47	0	24	71	1408

## Intersection Turning Movement Count

City/County: Cape Coral/Lee  
 Weather: Light Rain 3:07-3:20pm  
 Comments:

File Name : BurntStoreRd&Vincent  
 Site Code : 19033  
 Start Date : 3/6/2024  
 Page No : 1

### Groups Printed- Heavy Vehicle

Start Time	BURNT STORE ROAD Southbound				BURNT STORE ROAD Northbound				VINCENT AVENUE Eastbound				Int. Total
	Left	Thru	Right	App. Total	Left	Thru	Right	App. Total	Left	Thru	Right	App. Total	
07:00 AM	0	7	0	7	0	18	0	18	0	0	0	0	25
07:15 AM	0	9	1	10	0	12	0	12	0	0	0	0	22
07:30 AM	0	3	1	4	2	7	0	9	0	0	1	1	14
07:45 AM	0	0	0	0	1	11	0	12	0	0	0	0	12
<b>Total</b>	<b>0</b>	<b>19</b>	<b>2</b>	<b>21</b>	<b>3</b>	<b>48</b>	<b>0</b>	<b>51</b>	<b>0</b>	<b>0</b>	<b>1</b>	<b>1</b>	<b>73</b>
08:00 AM	0	12	1	13	0	6	0	6	0	0	0	0	19
08:15 AM	0	13	0	13	0	16	0	16	0	0	0	0	29
08:30 AM	0	7	3	10	1	11	0	12	0	0	0	0	22
08:45 AM	0	12	2	14	1	23	0	24	0	0	0	0	38
<b>Total</b>	<b>0</b>	<b>44</b>	<b>6</b>	<b>50</b>	<b>2</b>	<b>56</b>	<b>0</b>	<b>58</b>	<b>0</b>	<b>0</b>	<b>0</b>	<b>0</b>	<b>108</b>
09:00 AM	0	17	2	19	1	11	0	12	1	0	0	1	32
09:15 AM	0	19	5	24	0	19	0	19	1	0	2	3	46
09:30 AM	0	20	1	21	2	8	0	10	2	0	2	4	35
09:45 AM	0	17	0	17	1	17	0	18	0	0	0	0	35
<b>Total</b>	<b>0</b>	<b>73</b>	<b>8</b>	<b>81</b>	<b>4</b>	<b>55</b>	<b>0</b>	<b>59</b>	<b>4</b>	<b>0</b>	<b>4</b>	<b>8</b>	<b>148</b>
10:00 AM	0	13	2	15	0	29	0	29	2	0	1	3	47
10:15 AM	0	11	1	12	1	21	0	22	1	0	0	1	35
10:30 AM	0	12	0	12	1	13	0	14	1	0	2	3	29
10:45 AM	0	17	0	17	0	20	0	20	0	0	0	0	37
<b>Total</b>	<b>0</b>	<b>53</b>	<b>3</b>	<b>56</b>	<b>2</b>	<b>83</b>	<b>0</b>	<b>85</b>	<b>4</b>	<b>0</b>	<b>3</b>	<b>7</b>	<b>148</b>
11:00 AM	0	14	1	15	1	18	0	19	1	0	2	3	37
11:15 AM	0	7	1	8	0	14	0	14	0	0	0	0	22
11:30 AM	0	13	1	14	1	11	0	12	0	0	2	2	28
11:45 AM	0	10	1	11	2	11	0	13	0	0	0	0	24
<b>Total</b>	<b>0</b>	<b>44</b>	<b>4</b>	<b>48</b>	<b>4</b>	<b>54</b>	<b>0</b>	<b>58</b>	<b>1</b>	<b>0</b>	<b>4</b>	<b>5</b>	<b>111</b>
12:00 PM	0	13	2	15	0	15	0	15	2	0	0	2	32
12:15 PM	0	11	0	11	0	16	0	16	3	0	0	3	30
12:30 PM	0	11	1	12	0	12	0	12	0	0	0	0	24
12:45 PM	0	14	1	15	0	6	0	6	1	0	0	1	22
<b>Total</b>	<b>0</b>	<b>49</b>	<b>4</b>	<b>53</b>	<b>0</b>	<b>49</b>	<b>0</b>	<b>49</b>	<b>6</b>	<b>0</b>	<b>0</b>	<b>6</b>	<b>108</b>
01:00 PM	0	16	0	16	0	9	0	9	0	0	0	0	25
01:15 PM	0	17	1	18	0	11	0	11	0	0	0	0	29
01:30 PM	0	7	1	8	0	19	0	19	2	0	0	2	29
01:45 PM	0	20	0	20	0	10	0	10	1	0	0	1	31
<b>Total</b>	<b>0</b>	<b>60</b>	<b>2</b>	<b>62</b>	<b>0</b>	<b>49</b>	<b>0</b>	<b>49</b>	<b>3</b>	<b>0</b>	<b>0</b>	<b>3</b>	<b>114</b>
02:00 PM	0	10	2	12	1	9	0	10	0	0	0	0	22
02:15 PM	0	15	1	16	0	9	0	9	1	0	2	3	28
02:30 PM	0	16	0	16	0	11	0	11	1	0	0	1	28
02:45 PM	0	11	0	11	0	8	0	8	1	0	0	1	20
<b>Total</b>	<b>0</b>	<b>52</b>	<b>3</b>	<b>55</b>	<b>1</b>	<b>37</b>	<b>0</b>	<b>38</b>	<b>3</b>	<b>0</b>	<b>2</b>	<b>5</b>	<b>98</b>
03:00 PM	0	13	0	13	1	6	0	7	0	0	0	0	20
03:15 PM	0	13	2	15	2	5	0	7	1	0	0	1	23
03:30 PM	0	11	3	14	0	3	0	3	0	0	0	0	17
03:45 PM	0	8	0	8	0	5	0	5	1	0	1	2	15
<b>Total</b>	<b>0</b>	<b>45</b>	<b>5</b>	<b>50</b>	<b>3</b>	<b>19</b>	<b>0</b>	<b>22</b>	<b>2</b>	<b>0</b>	<b>1</b>	<b>3</b>	<b>75</b>
04:00 PM	0	11	0	11	0	2	0	2	1	0	0	1	14
04:15 PM	0	12	0	12	0	4	0	4	1	0	0	1	17
04:30 PM	0	15	0	15	0	5	0	5	0	0	1	1	21
04:45 PM	0	6	0	6	0	2	0	2	0	0	0	0	8
<b>Total</b>	<b>0</b>	<b>44</b>	<b>0</b>	<b>44</b>	<b>0</b>	<b>13</b>	<b>0</b>	<b>13</b>	<b>2</b>	<b>0</b>	<b>1</b>	<b>3</b>	<b>60</b>

## Intersection Turning Movement Count

File Name : BurntStoreRd&Vincent  
 Site Code : 19033  
 Start Date : 3/6/2024  
 Page No : 2

### Groups Printed- Heavy Vehicle

Start Time	BURNT STORE ROAD Southbound				BURNT STORE ROAD Northbound				VINCENT AVENUE Eastbound				Int. Total
	Left	Thru	Right	App. Total	Left	Thru	Right	App. Total	Left	Thru	Right	App. Total	
05:00 PM	0	5	0	5	0	5	0	5	0	0	0	0	10
05:15 PM	0	5	0	5	0	4	0	4	0	0	0	0	9
05:30 PM	0	2	0	2	0	7	0	7	1	0	0	1	10
05:45 PM	0	4	1	5	0	3	0	3	0	0	0	0	8
<b>Total</b>	0	16	1	17	0	19	0	19	1	0	0	1	37
06:00 PM	0	2	0	2	0	7	0	7	0	0	0	0	9
06:15 PM	0	4	0	4	0	1	0	1	0	0	0	0	5
06:30 PM	0	3	0	3	0	2	0	2	0	0	0	0	5
06:45 PM	0	4	0	4	0	2	0	2	0	0	0	0	6
<b>Total</b>	0	13	0	13	0	12	0	12	0	0	0	0	25
<b>Grand Total</b>	0	512	38	550	19	494	0	513	26	0	16	42	1105
Approch %	0	93.1	6.9		3.7	96.3	0		61.9	0	38.1		
Total %	0	46.3	3.4	49.8	1.7	44.7	0	46.4	2.4	0	1.4	3.8	

Start Time	BURNT STORE ROAD Southbound				BURNT STORE ROAD Northbound				VINCENT AVENUE Eastbound				Int. Total
	Left	Thru	Right	App. Total	Left	Thru	Right	App. Total	Left	Thru	Right	App. Total	
Peak Hour Analysis From 07:00 AM to 06:45 PM - Peak 1 of 1													
Peak Hour for Entire Intersection Begins at 09:15 AM													
09:15 AM	0	19	5	24	0	19	0	19	1	0	2	3	46
09:30 AM	0	20	1	21	2	8	0	10	2	0	2	4	35
09:45 AM	0	17	0	17	1	17	0	18	0	0	0	0	35
10:00 AM	0	13	2	15	0	29	0	29	2	0	1	3	47
<b>Total Volume</b>	0	69	8	77	3	73	0	76	5	0	5	10	163
<b>% App. Total</b>	0	89.6	10.4		3.9	96.1	0		50	0	50		
<b>PHF</b>	.000	.863	.400	.802	.375	.629	.000	.655	.625	.000	.625	.625	.867

Peak Hour Analysis From 07:00 AM to 06:45 PM - Peak 1 of 1

Peak Hour for Each Approach Begins at:

	09:00 AM				10:00 AM				09:15 AM			
+0 mins.	0	17	2	19	0	29	0	29	1	0	2	3
+15 mins.	0	19	5	24	1	21	0	22	2	0	2	4
+30 mins.	0	20	1	21	1	13	0	14	0	0	0	0
+45 mins.	0	17	0	17	0	20	0	20	2	0	1	3
<b>Total Volume</b>	0	73	8	81	2	83	0	85	5	0	5	10
<b>% App. Total</b>	0	90.1	9.9		2.4	97.6	0		50	0	50	
<b>PHF</b>	.000	.913	.400	.844	.500	.716	.000	.733	.625	.000	.625	.625



# Intersection Pedestrian & Bicycle Count

Date: 3/6/2024

Day: Wednesday

Count Times: 7am - 7pm

Weather: Lt Rain 3:07-3:20pm

Intersection: Burnt Store Road at Vincent Boulevard

Comments: \_\_\_\_\_

**C - Children under 12; S - Seniors 65 or over; D - Physical Disability**

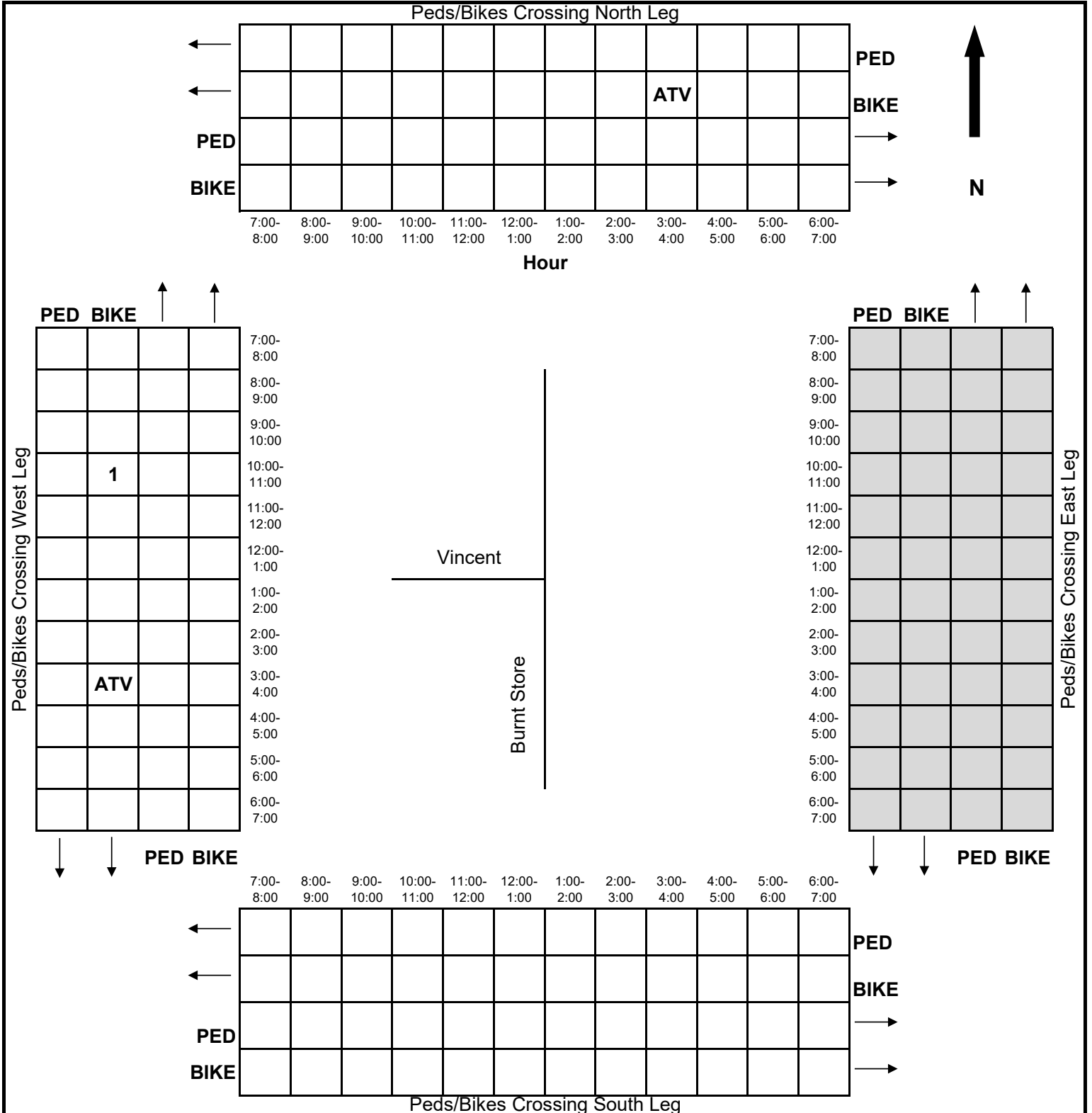

**Appendix B**  
**Signal Warrant Analysis**

**Existing Year (2024) Traffic Count Volumes - Burnt Store Road at Vincent Avenue**

Time Period Begins	NB	SB	EB	Major Street Approaches	Minor Street Approach	Total Volume	Minor Approach Rank
7:00 AM	718	374	40	1,092	40	1,132	
8:00 AM	682	395	46	1,077	46	1,123	
9:00 AM	570	454	85	1,024	85	1,109	5
10:00 AM	624	531	106	1,155	106	1,261	2
11:00 AM	582	534	76	1,116	76	1,192	6
12:00 PM	555	646	115	1,201	115	1,316	1
1:00 PM	506	637	84	1,143	84	1,227	4
2:00 PM	433	684	87	1,117	87	1,204	3
3:00 PM	500	816	60	1,316	60	1,376	
4:00 PM	457	917	74	1,374	74	1,448	7
5:00 PM	411	779	70	1,190	70	1,260	8
6:00 PM	303	542	32	845	32	877	



## Opening Year (2025) Build Volumes – Burnt Store Road at Vincent Avenue

Time Period Begins	NB	SB	EB	Major Street Approaches	Minor Street Approach	Minor St without RT	Minor St w/50% RT	Minor Approach Rank
7:00 AM	777	405	41	1,182	41	28	34	
8:00 AM	738	427	47	1,165	47	32	39	
9:00 AM	617	492	87	1,109	87	59	73	5
10:00 AM	675	575	109	1,250	109	74	92	2
11:00 AM	630	578	78	1,208	78	54	66	6
12:00 PM	600	699	118	1,299	118	81	100	1
1:00 PM	547	689	86	1,236	86	59	73	4
2:00 PM	468	741	89	1,209	89	61	75	3
3:00 PM	541	883	62	1,424	62	43	52	
4:00 PM	494	993	76	1,487	76	50	63	7
5:00 PM	445	842	72	1,287	72	48	60	8
6:00 PM	328	586	33	914	33	22	27	

Note: Future traffic volumes were projected using recommended annual linear growth rates of 8.2% for the Burnt Store Road mainline and 2.7% for side streets as documented in the Project Traffic Analysis Report.

## Design Year (2045) Build Volumes – Burnt Store Road at Vincent Avenue

Time Period Begins	NB	SB	EB	Major Street Approaches	Minor Street Approach	Minor St without RT	Minor Approach Rank
7:00 AM	1,955	1,018	63	2,972	63	43	
8:00 AM	1,857	1,075	72	2,932	72	49	
9:00 AM	1,552	1,235	134	2,787	134	91	5
10:00 AM	1,698	1,445	166	3,144	166	113	2
11:00 AM	1,584	1,454	119	3,038	119	82	6
12:00 PM	1,510	1,758	180	3,269	180	124	1
1:00 PM	1,377	1,734	132	3,111	132	91	4
2:00 PM	1,178	1,862	136	3,040	136	94	3
3:00 PM	1,361	2,221	94	3,582	94	65	
4:00 PM	1,244	2,496	116	3,740	116	77	7
5:00 PM	1,119	2,120	110	3,239	110	73	8
6:00 PM	825	1,475	50	2,300	50	33	

Note: Future traffic volumes were projected using recommended annual linear growth rates of 8.2% for the Burnt Store Road mainline and 2.7% for side streets as documented in the Project Traffic Analysis Report.

# TRAFFIC SIGNAL WARRANT SUMMARY

City: **Cape Coral**  
County: **12 – Lee**  
District: **One**

Engineer: **Giri Jeedigunta**  
Date: **September 2, 2024**

Major Street: **Burnt Store Rd** Lanes: **2** Major Approach Speed: **50**  
Minor Street: **Vincent Ave (w/50% RT)** Lanes: **1** Minor Approach Speed: **30**

MUTCD Electronic Reference to Chapter 4: <http://mutcd.fhwa.dot.gov/pdfs/2009r1r2/part4.pdf>

### Volume Level Criteria

1. Is the posted speed or 85th-percentile of major street > 40 mph?  Yes  No
2. Is the intersection in a built-up area of an isolated community with a population < 10,000?  Yes  No
- "70%" volume level **may** be used if Question 1 **or** 2 above is answered "Yes"  MAY  70%  100%

### WARRANT 1 - EIGHT-HOUR VEHICULAR VOLUME

Warrant 1 is satisfied if Condition A **or** Condition B is "100%" satisfied for eight hours.  Yes  No

Warrant 1 is also satisfied if both Condition A **and** Condition B are "80%" satisfied (should only be applied after an adequate trial of other alternatives that could cause less delay and inconvenience to traffic has failed to solve the traffic problems).  Yes  No

Warrant 1 is satisfied if Condition A **or** Condition B is "70%" satisfied for eight hours.  Yes  No

#### Condition A - Minimum Vehicular Volume

Condition A is intended for application at locations where a large volume of intersecting traffic is the principal reason to consider installing a traffic control signal.

- Applicable:  Yes  No
- 100% Satisfied:  Yes  No
- 80% Satisfied:  Yes  No
- 70% Satisfied:  Yes  No

Number of Lanes for moving traffic on each approach		Vehicles per hour on major-street (total of both approaches)			Vehicles per hour on minor-street (one direction only)		
Major	Minor	100% <sup>a</sup>	80% <sup>b</sup>	70% <sup>c</sup>	100% <sup>a</sup>	80% <sup>b</sup>	70% <sup>c</sup>
1	1	500	400	350	150	120	105
2 or more	1	600	480	420	150	120	105
2 or more	2 or more	600	480	420	200	160	140
1	2 or more	500	400	350	200	160	140

<sup>a</sup> Basic Minimum hourly volume

<sup>b</sup> Used for combination of Conditions A and B after adequate trial of other remedial measures

<sup>c</sup> May be used when the major-street speed exceeds 40 mph or in an isolated community with a population of less than 10,000

Record 8 highest hours and the corresponding major-street and minor-street volumes in the Instructions Sheet.

Street	Eight Highest Hours							
	9:00 AM	10:00 AM	11:00 AM	12:00:00 NOON	1:00 PM	2:00 PM	4:00 PM	5:00 PM
Major	1,109	1,250	1,208	1,299	1,236	1,209	1,487	1,287
Minor	73	92	66	100	73	75	63	60

Existing Volumes

State of Florida Department of Transportation  
**TRAFFIC SIGNAL WARRANT SUMMARY**

**Condition B - Interruption of Continuous Traffic**

Condition B is intended for application where Condition A is not satisfied and the traffic volume on a major street is so heavy that traffic on the minor intersecting street suffers excessive delay or conflict in entering or crossing the major street.

Applicable:	<input checked="" type="checkbox"/> Yes	<input type="checkbox"/> No
100% Satisfied:	<input type="checkbox"/> Yes	<input checked="" type="checkbox"/> No
80% Satisfied:	<input checked="" type="checkbox"/> Yes	<input type="checkbox"/> No
70% Satisfied:	<input checked="" type="checkbox"/> Yes	<input type="checkbox"/> No

Number of Lanes for moving traffic on each approach		Vehicles per hour on major-street (total of both approaches)			Vehicles per hour on minor-street (one direction only)		
Major	Minor	100% <sup>a</sup>	80% <sup>b</sup>	70% <sup>c</sup>	100% <sup>a</sup>	80% <sup>b</sup>	70% <sup>c</sup>
1	1	750	600	525	75	60	53
2 or more	1	900	720	630	75	60	53
2 or more	2 or more	900	720	630	100	80	70
1	2 or more	750	600	525	100	80	70

<sup>a</sup> Basic Minimum hourly volume

<sup>b</sup> Used for combination of Conditions A and B after adequate trial of other remedial measures

<sup>c</sup> May be used when the major-street speed exceeds 40 mph or in an isolated community with a population of less than 10,000

Record 8 highest hours and the corresponding major-street and minor-street volumes in the Instructions Sheet.

Eight Highest Hours								
Street	9:00 AM	10:00 AM	11:00 AM	12:00:00 NOON	1:00 PM	2:00 PM	4:00 PM	5:00 PM
Major	1,109	1,250	1,208	1,299	1,236	1,209	1,487	1,287
Minor	73	92	66	100	73	75	63	60

Existing Volumes

# TRAFFIC SIGNAL WARRANT SUMMARY

City: **Cape Coral**  
County: **12 – Lee**  
District: **One**

Engineer: **Giri Jeedigunta**  
Date: **September 2, 2024**

Major Street: **Burnt Store Rd**  
Minor Street: **Vincent Ave (w/o RT)**

Lanes: **2** Major Approach Speed: **50**  
Lanes: **91** Minor Approach Speed: **30**

MUTCD Electronic Reference to Chapter 4: <http://mutcd.fhwa.dot.gov/pdfs/2009r1r2/part4.pdf>

### Volume Level Criteria

1. Is the posted speed or 85th-percentile of major street > 40 mph?  Yes  No
2. Is the intersection in a built-up area of an isolated community with a population < 10,000?  Yes  No
- "70%" volume level **may** be used if Question 1 **or** 2 above is answered "Yes"  MAY  70%  100%

### WARRANT 1 - EIGHT-HOUR VEHICULAR VOLUME

Warrant 1 is satisfied if Condition A **or** Condition B is "100%" satisfied for eight hours.  Yes  No

Warrant 1 is also satisfied if both Condition A **and** Condition B are "80%" satisfied (should only be applied after an adequate trial of other alternatives that could cause less delay and inconvenience to traffic has failed to solve the traffic problems).  Yes  No

Warrant 1 is satisfied if Condition A **or** Condition B is "70%" satisfied for eight hours.  Yes  No

#### Condition A - Minimum Vehicular Volume

Condition A is intended for application at locations where a large volume of intersecting traffic is the principal reason to consider installing a traffic control signal.

Applicable:  Yes  No

100% Satisfied:  Yes  No

80% Satisfied:  Yes  No

70% Satisfied:  Yes  No

Number of Lanes for moving traffic on each approach		Vehicles per hour on major-street (total of both approaches)			Vehicles per hour on minor-street (one direction only)		
Major	Minor	100% <sup>a</sup>	80% <sup>b</sup>	70% <sup>c</sup>	100% <sup>a</sup>	80% <sup>b</sup>	70% <sup>c</sup>
1	1	500	400	350	150	120	105
2 or more	1	600	480	420	150	120	105
2 or more	2 or more	600	480	420	200	160	140
1	2 or more	500	400	350	200	160	140

<sup>a</sup> Basic Minimum hourly volume

<sup>b</sup> Used for combination of Conditions A and B after adequate trial of other remedial measures

<sup>c</sup> May be used when the major-street speed exceeds 40 mph or in an isolated community with a population of less than 10,000

Record 8 highest hours and the corresponding major-street and minor-street volumes in the Instructions Sheet.

Street	Eight Highest Hours							
	9:00 AM	10:00 AM	11:00 AM	12:00:00 NOON	1:00 PM	2:00 PM	4:00 PM	5:00 PM
Major	2,787	3,144	3,038	3,269	3,111	3,040	3,740	3,239
Minor	91	113	82	124	91	94	77	73

Existing Volumes

State of Florida Department of Transportation  
**TRAFFIC SIGNAL WARRANT SUMMARY**

**Condition B - Interruption of Continuous Traffic**

Condition B is intended for application where Condition A is not satisfied and the traffic volume on a major street is so heavy that traffic on the minor intersecting street suffers excessive delay or conflict in entering or crossing the major street.

Applicable:	<input checked="" type="checkbox"/> Yes	<input type="checkbox"/> No
100% Satisfied:	<input type="checkbox"/> Yes	<input checked="" type="checkbox"/> No
80% Satisfied:	<input checked="" type="checkbox"/> Yes	<input type="checkbox"/> No
70% Satisfied:	<input checked="" type="checkbox"/> Yes	<input type="checkbox"/> No

Number of Lanes for moving traffic on each approach		Vehicles per hour on major-street (total of both approaches)			Vehicles per hour on minor-street (one direction only)		
Major	Minor	100% <sup>a</sup>	80% <sup>b</sup>	70% <sup>c</sup>	100% <sup>a</sup>	80% <sup>b</sup>	70% <sup>c</sup>
1	1	750	600	525	75	60	53
2 or more	1	900	720	630	75	60	53
2 or more	2 or more	900	720	630	100	80	70
1	2 or more	750	600	525	100	80	70

<sup>a</sup> Basic Minimum hourly volume

<sup>b</sup> Used for combination of Conditions A and B after adequate trial of other remedial measures

<sup>c</sup> May be used when the major-street speed exceeds 40 mph or in an isolated community with a population of less than 10,000

Record 8 highest hours and the corresponding major-street and minor-street volumes in the Instructions Sheet.

Eight Highest Hours								
Street	9:00 AM	10:00 AM	11:00 AM	12:00:00 NOON	1:00 PM	2:00 PM	4:00 PM	5:00 PM
Major	2,787	3,144	3,038	3,269	3,111	3,040	3,740	3,239
Minor	91	113	82	124	91	94	77	73

Existing Volumes

**Appendix C**  
**Traffic Projections**

# Hourly Traffic Volume Distribution

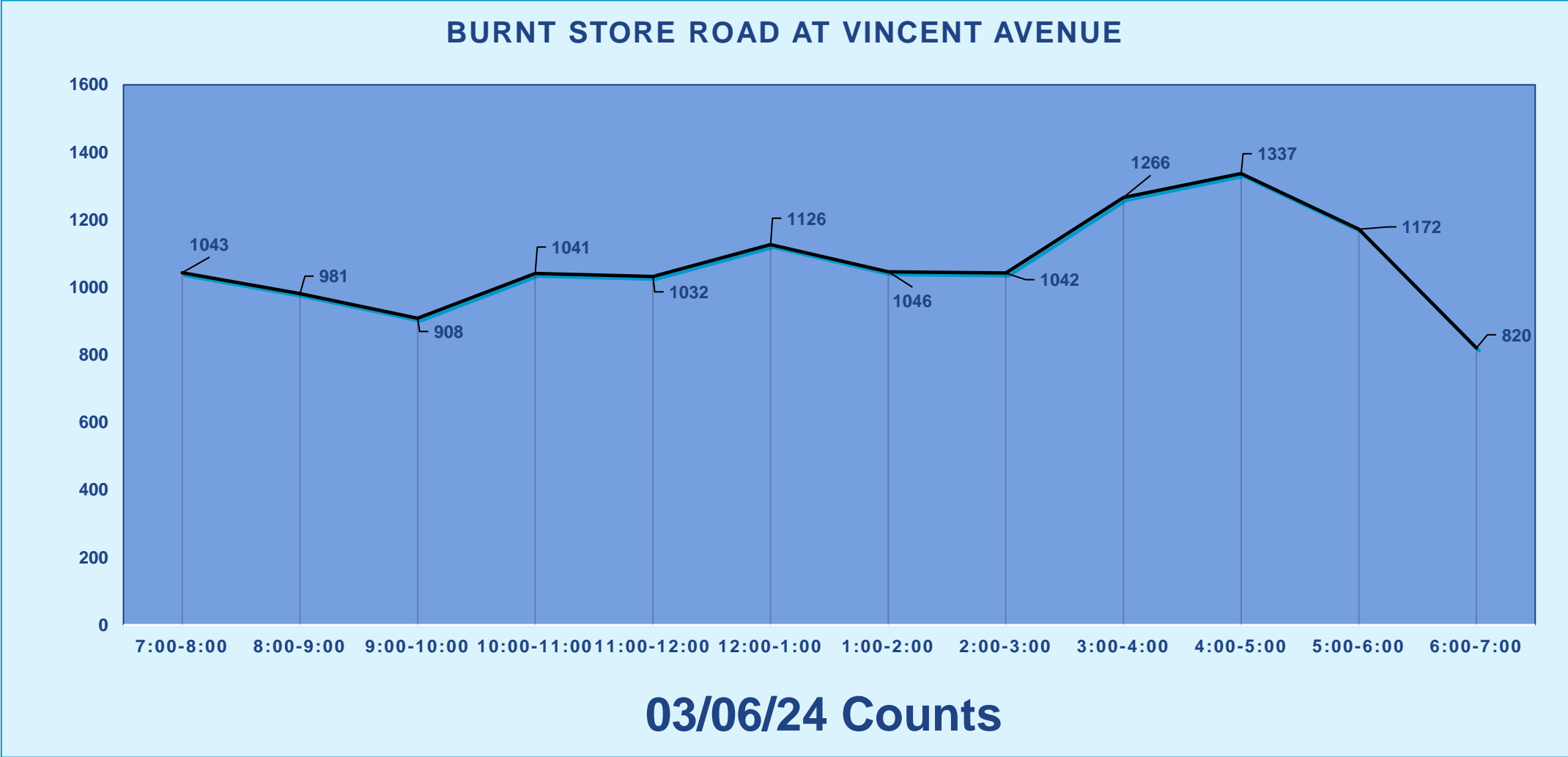



# Hourly Traffic Volumes Comparison - 2024 vs 2021

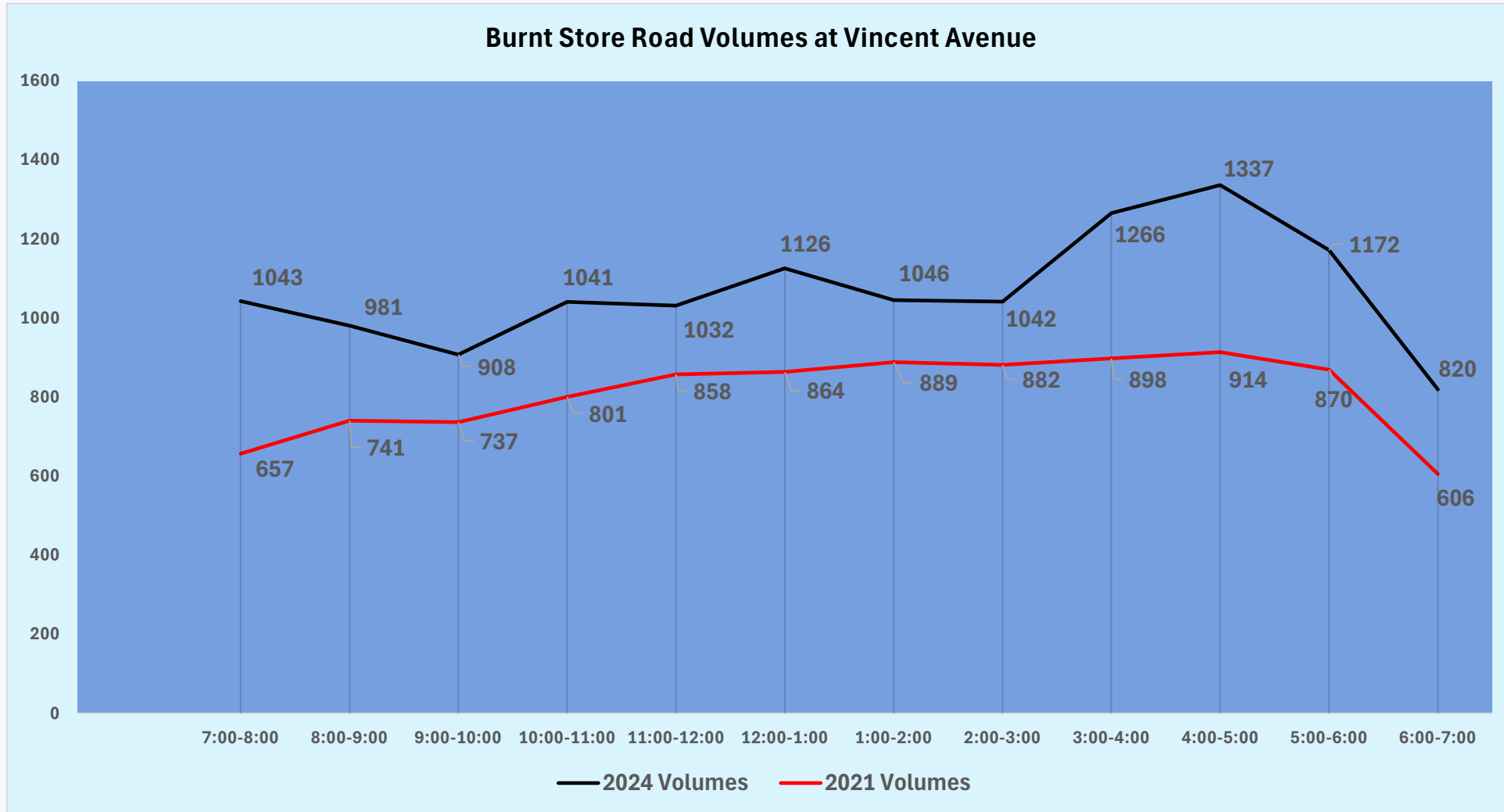

# Peak Hour Volumes at Vincent Avenue (2024)

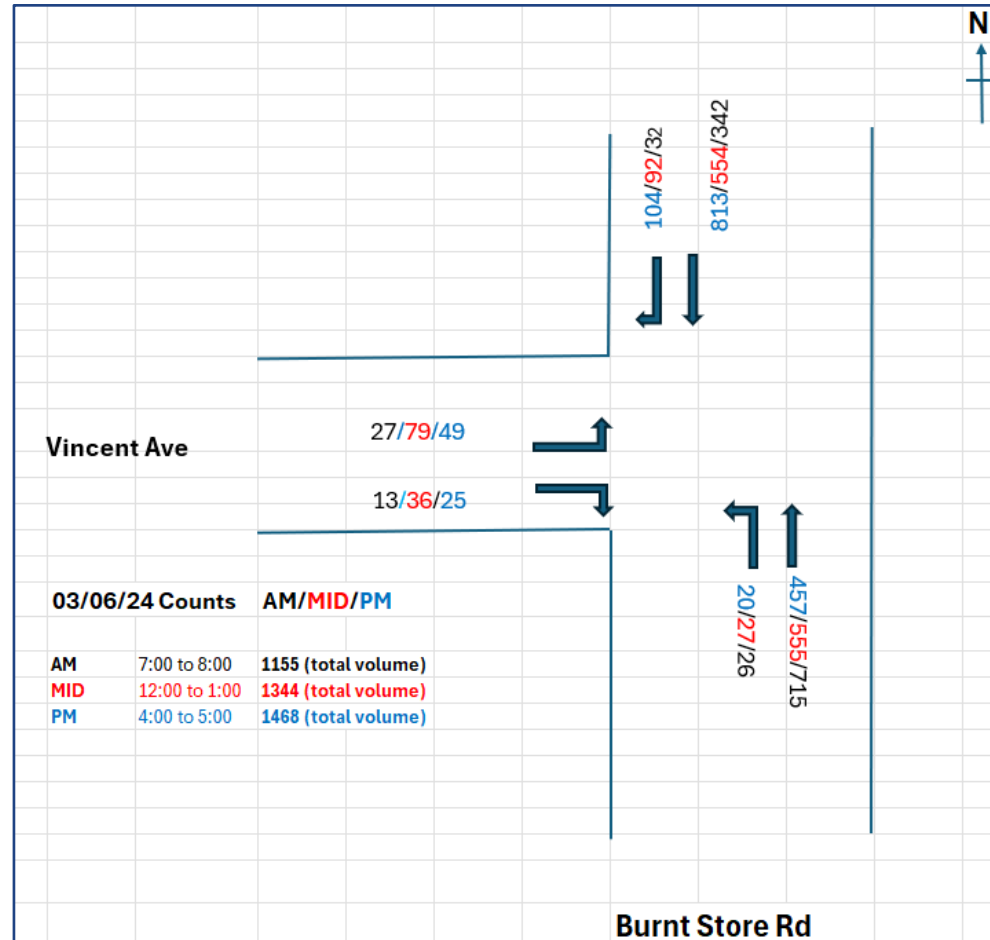

Existing Volumes (March 2024)

# Projected Peak Hour Volumes at Vincent Avenue (Opening & Design Years)

Based on annual growth rate of 8.2% for Burnt Store Road and 2.7% for side streets (PTAR)

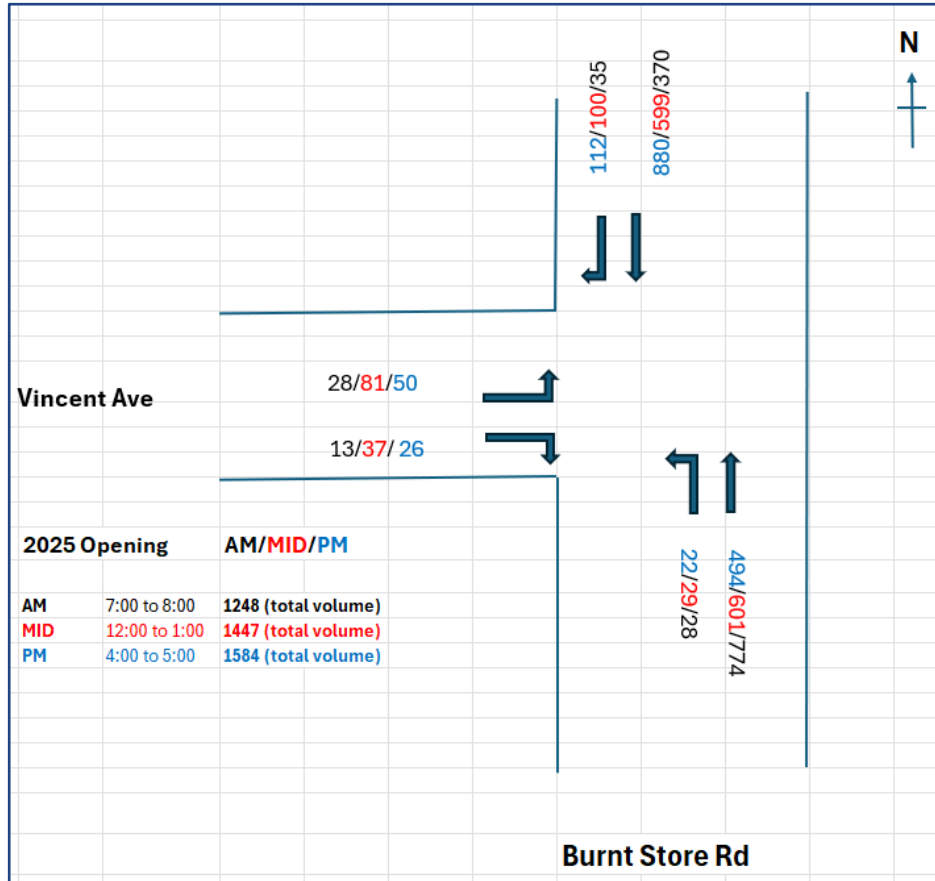

Opening Year (2025) VOLUMES

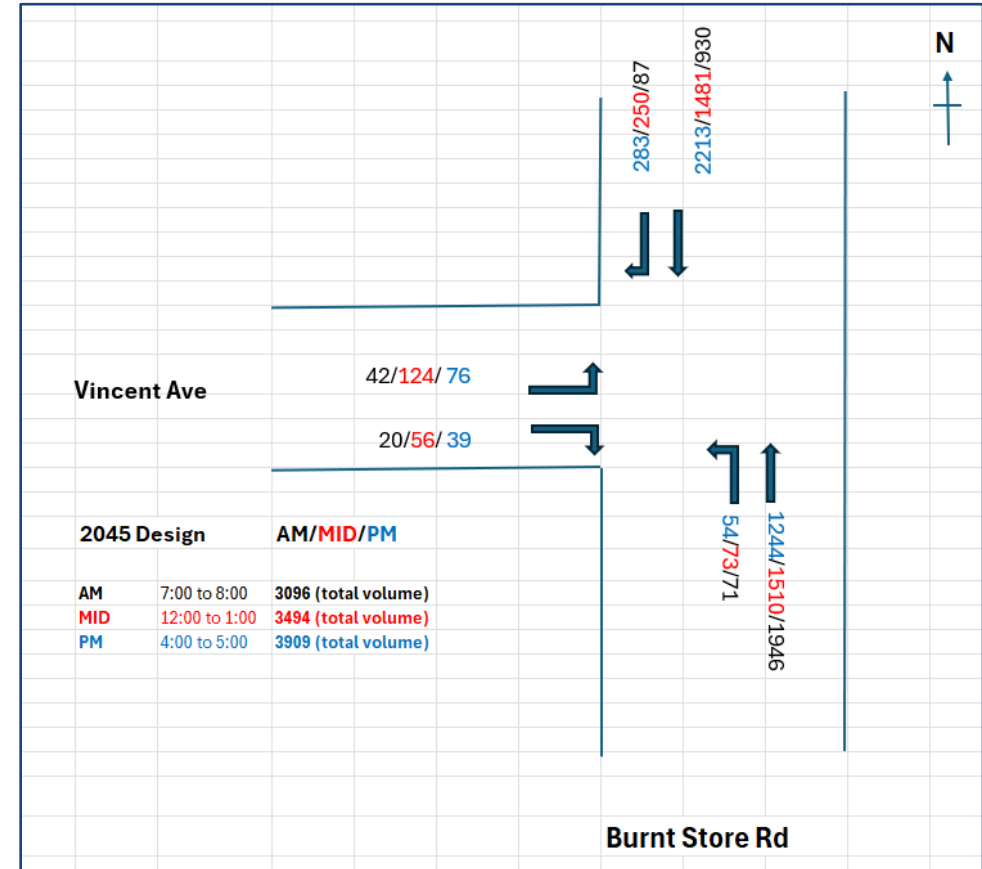

Design Year (2045) VOLUMES

**Appendix D**  
**ICE Forms**

**Florida Department of Transportation**  
**Intersection Control Evaluation (ICE) Form**  
**Stage 1: Screening**

Intersection Control Evaluation Form 750-010-30

To fulfill the requirements of Stage 1 (Screening) of FDOT's ICE procedures, complete the following form and append all supporting documentation. Completed forms are to be submitted to the District Traffic Operations Engineer (DTOE) and District Design Engineer (DDE) for the project's approval.

Project Name	Burnt Store Rd from Van Buren Parkway to Charlotte County Line PD&E Study	FDOT Project #	436928-1		
Submitted By	Scalar Consulting Group Inc	Agency/Company	FDOT D1	Date	11/8/2024
Email	<a href="mailto:gjeedigunta@scalarinc.net">gjeedigunta@scalarinc.net</a>	FDOT District	District 1	County	Lee
Project Locality (City/Town/Village)	Cape Coral				
Intersection Type	At-Grade Intersection	FDOT Context Classification	C2 - Rural		
Project Funding Source	Federal	Project Type	Corridor Improvement Project		
Project Purpose (What is the catalyst for this project and why is it being undertaken?)	Intersection meets warrants for signalization. Warrant 1B is met based on the design year volumes with the right turns from Vincent Avenue are excluded. Warrant 1B is met when 50% right turns are included based on the opening year traffic volumes. Daily truck percent on Burnt Store Rd is 7.5% and on Vincent Ave is 4.5%. Purpose of the project is to improve the local and regional transportation network, and provide multimodal pathways along Burnt Store Rd.				
Project Setting Description (Describe the area surrounding the intersection)	Burnt Store Rd is an off-system rural roadway with 50 MPH posted speed. Project will expand Burnt Store Rd from a 2-lane undivided roadway to a 4-lane divided roadway. Land uses surrounding the intersection consist of natural areas associated with conservation lands (Yucca Pens) and low and medium density residential uses.				
Multimodal Context (Describe the pedestrian, bicycle, and transit activity in the area and the potential for activity based on surrounding land uses and development patterns)	There is a pedestrian crosswalk to cross Vincent Avenue with a sidewalk on the west side of Burnt Store Rd. that begins on the north side of Vincent Ave. and extends to the north. There is also a sidewalk on the north side of Vincent Ave. Traffic counts data showed only one pedestrian crossing in 8 hours. However, the project will add 10 ft wide multiuse pathways on both sides of Burnt Store Rd. Lee County will monitor changes in pedestrian demand with changes in future development, and install a signalized crossing across Burnt Store Rd when determined needed.				

Major Street Information									
Route #:		Route Name(s)	Burnt Store Rd/CR 765			Milepost			
Existing Control Type	Two-way Stop-Control		Existing AADT	17,800	Design Year AADT	48,600			
Design Vehicle	Florida Interstate Semitrailer (WB-62FL)		Control Vehicle	Florida Interstate Semitrailer (WB-62FL)					
Primary Functional Classification	Rural Principal Arterial - Other				Design Speed (mph)	50			
Secondary Functional Classification (if app.)					Target Speed (mph) [if app.]				
Approach #1	Direction	Southbound		Number of Lanes		Study Period #1 Traffic Volumes		Study Period #2 Traffic Volumes	
	Sidewalks along:	Both sides of the approach		Left-Turn	0	Weekday Midday Peak		Weekday PM Peak	
	Crosswalk on Approach?	Yes		Left-Through					
	On-Street Bike Facilities?	Yes		Through	2	Left		Left	
	Multi-Use Path?	Yes		Left-Through-Right		Through	1,481	Through	2,213
	Scheduled Bus Service?	No		Through-Right		Right	250	Right	283
	Bus Stop on Approach?	No		Right-Turn	1	Daily Truck %		7.5%	
Approach #2	Direction	Northbound		Number of Lanes		Study Period #1 Traffic Volumes		Study Period #2 Traffic Volumes	
	Sidewalks along:	Both sides of the approach		Left-Turn	1	Weekday Midday Peak		Weekday PM Peak	
	Crosswalk on Approach?	Yes		Left-Through					
	On-Street Bike Facilities?	Yes		Through	2	Left	73	Left	71
	Multi-Use Path?	Yes		Left-Through-Right		Through	1,510	Through	1,946
	Scheduled Bus Service?	No		Through-Right		Right		Right	
	Bus Stop on Approach?	No		Right-Turn	0	Daily Truck %		7.8%	

Minor Street Information											
Route #:		Route Name(s)			Vincent Ave			Milepost (if app.)			
Existing Control Type		Two-way Stop-Control			Existing AADT		2,300		Design Year AADT	3,600	
Design Vehicle		Florida Interstate Semitrailer (WB-62FL)			Control Vehicle		Florida Interstate Semitrailer (WB-62FL)				
Primary Functional Classification				Rural Minor Collector				Design Speed (mph)		30	
Secondary Functional Classification (if app.)								Target Speed (mph) [if app.]			
Approach #1	Direction		Eastbound			Number of Lanes		Study Period #1 Traffic Volumes		Study Period #2 Traffic Volumes	
	Sidewalks along:		One side of the approach			Left-Turn		1			
	Crosswalk on Approach?		No			Left-Through		Weekday Midday Peak		Weekday PM Peak	
	On-Street Bike Facilities?		No			Through		Left		124	
	Multi-Use Path?		Yes			Left-Through-Right		Through		Left	
	Scheduled Bus Service?		No			Through-Right		Right		76	
	Bus Stop on Approach?		No			Right-Turn		1		Daily Truck %	
									4.8%		
Approach #2	Direction					Number of Lanes		Study Period #1 Traffic Volumes		Study Period #2 Traffic Volumes	
	Sidewalks along:					Left-Turn					
	Crosswalk on Approach?					Left-Through		Weekday Midday Peak		Weekday PM Peak	
	On-Street Bike Facilities?					Through		Left		Left	
	Multi-Use Path?					Left-Through-Right		Through		Through	
	Scheduled Bus Service?					Through-Right		Right		Right	
	Bus Stop on Approach?					Right-Turn				Daily Truck %	
Approach #3	Direction					Number of Lanes		Study Period #1 Traffic Volumes		Study Period #2 Traffic Volumes	
	Sidewalks along:					Left-Turn					
	Crosswalk on Approach?					Left-Through		Weekday Midday Peak		Weekday PM Peak	
	On-Street Bike Facilities?					Through		Left		Left	
	Multi-Use Path?					Left-Through-Right		Through		Through	
	Scheduled Bus Service?					Through-Right		Right		Right	
	Bus Stop on Approach?					Right-Turn				Daily Truck %	

Crash History (Existing Intersections Only)
Append the most recent five-years of crash data for the intersection from the CAR System. If the crash data evidences any issues relating to safety performance, discuss briefly here:
Total 17 crashes reported during the period from 2019-2023. 8 NB crashes (rear ends); 4 EBLT crashes; 5 SB crashes (off-road and animal crossing)

Control Strategy Evaluation								
Provide a brief justification as to why each of the following control strategies should be advanced or not. Justification should consider potential environmental impacts.								
Control Strategy	CAP-X Outputs				SPICE Outputs		Strategy to be Advanced?	Justification
	V/C Ratio		Ped Accom. Score	Bike Accom. Score	Crash Prediction Rank	SSI Rank		
	Weekday Midday Peak	Weekday PM Peak						
Two-Way Stop-Control	9.04	>10			3	7	No	V/C out of acceptable range.
Signalized Control	0.57	0.75			7	5	No	Meets capacity requirements but Lee County prefers the CGT over a signalized control to allow for continuous northbound movement.
Roundabout (1-lane)	1.42	2.01			1	1	No	V/C out of range; Not applicable for a 4-lane divided roadway.
Roundabout (2-lane)	0.72	1.03			5	2	No	V/C for PM peak exceeds 1.0, vetted further with SIDRA analysis. Requires additional ROW. Not a preferred option by the local agencies.
Restricted Crossing U-turn (Signalized)	0.56	0.73			2	3	No	Meets capacity requirements, but requires additional ROW for the U-turns. Not a preferred option by Lee County or by the public.
Restricted Crossing U-turn (Unsignalized)	1.91	4.20			4	4	No	V/C out of acceptable range.
Continuous Green Tee	0.57	0.75			6	6	Yes	Meets V/C requirements, requires no additional ROW. Preferred option by Lee County and accepted by Charlotte County. Provides free flow for NB in case of evacuations.

Resolution				
<i>To be filled out by FDOT District Traffic Operations Engineer and District Design Engineer</i>				
Project Determination		Identified Control Strategy Approved		
Comments	Lee County's preference of the CGT has been accepted by FDOT at the 03/29/24 FDOT-Lee County design coordination meeting and accepted by the Charlotte County MPO Board during their board meeting on 10/21/24. Roadway alignment analysis determined that the CGT option can fit within the existing roadway ROW. Stage 2 assessment is not required.			
DTOE Name		Signature		Date
DDE Name		Signature		Date



TYPE OF INTERSECTION	Overall V/C Ratio	V/C Ranking	Pedestrian Accommodation Score	Bicycle Accommodation Score
Signalized Restricted Crossing U-Turn N-S	0.73	1	--	--
Traffic Signal	0.75	2	--	--
Continuous Green T W	0.75	2	--	--
2NS X 1EW	1.03	4	--	--
1 X 1	2.01	5	--	--
Unsignalized Restricted Crossing U-Turn N-S	4.20	6	--	--
Two-Way Stop Control N-S	>10	--	--	--
--	--	--	--	--
--	--	--	--	--
--	--	--	--	--

Florida Department of Transportation											
Safety Performance for Intersection Control Evaluation Tool											
Results											
Summary of crash prediction results for each alternative											
Project Information											
Project Name:	Burnt Store Rd FCBE Study	Intersection Type:	At-Grade Intersection								
Intersection:	Burnt Store Rd & Vincent Ave	Opening Year:	2025								
Agency:	FSOT-03	Design Year:	2045								
Project Reference:	FWD 436/28-1	Funding Type:	On Rural Multi-lane Highway								
City:	Calhoun County	Number of Lanes:	3-Lane								
State:	FL	Major Street Lanes (Both Directions):	1-Way/2-Way								
Open:	1/17/2024	Major Street Approach Speed:									
Analyst:	Scalar Consulting Group, Inc										
Crash Prediction Summary								SSI Score			
Control Strategy	Crash Type	Opening Year	Design Year	Total Project Life Cycle	Crash Prediction Rank	AADT Within SPF Prediction Range?		Source of Prediction	Opening Year	Design Year	Rank
						(Open Year)	(Design Year)				
Traffic Signal	Total	4.19	12.59	172.95	7	Yes	Yes	Calibrated SPF	96	82	5
	Fatal & Injury	1.56	4.24	60.35							
Minor Road Stop	Total	1.51	4.46	60.08	3	Yes	Yes	Calibrated SPF	93	68	7
	Fatal & Injury	0.54	1.57	21.81							
1-lane Roundabout	Total	1.12	2.67	33.75	1	No	No	Uncalibrated SPF	100	99	1
	Fatal & Injury	0.23	0.65	22.33							
2-lane Roundabout	Total	4.17	11.04	158.62	5	Yes	No	Uncalibrated SPF	100	98	2
	Fatal & Injury	0.76	2.39	32.34							
Signalized RCLT	Total	1.81	6.01	79.77	2	Yes	Yes	Uncalibrated SPF	98	88	3
	Fatal & Injury	0.46	1.54	20.15							
Unsignalized RCLT	Total	2.60	5.50	81.80	4	Yes	No	Uncalibrated SPF	97	85	4
	Fatal & Injury	0.81	1.56	25.60							
Continuous Green-T Intersection	Total	4.03	12.09	166.03	6	N/A	N/A	CMF	96	82	6
	Fatal & Injury	1.32	3.61	51.30							

Legend	
Red	AADT >= 75%
Orange	AADT >= 50%
Yellow	AADT >= 25%
Light Green	AADT >= 10%
Dark Green	AADT < 10%

**Appendix E**  
**Concept Plans**

# Roundabout Concept

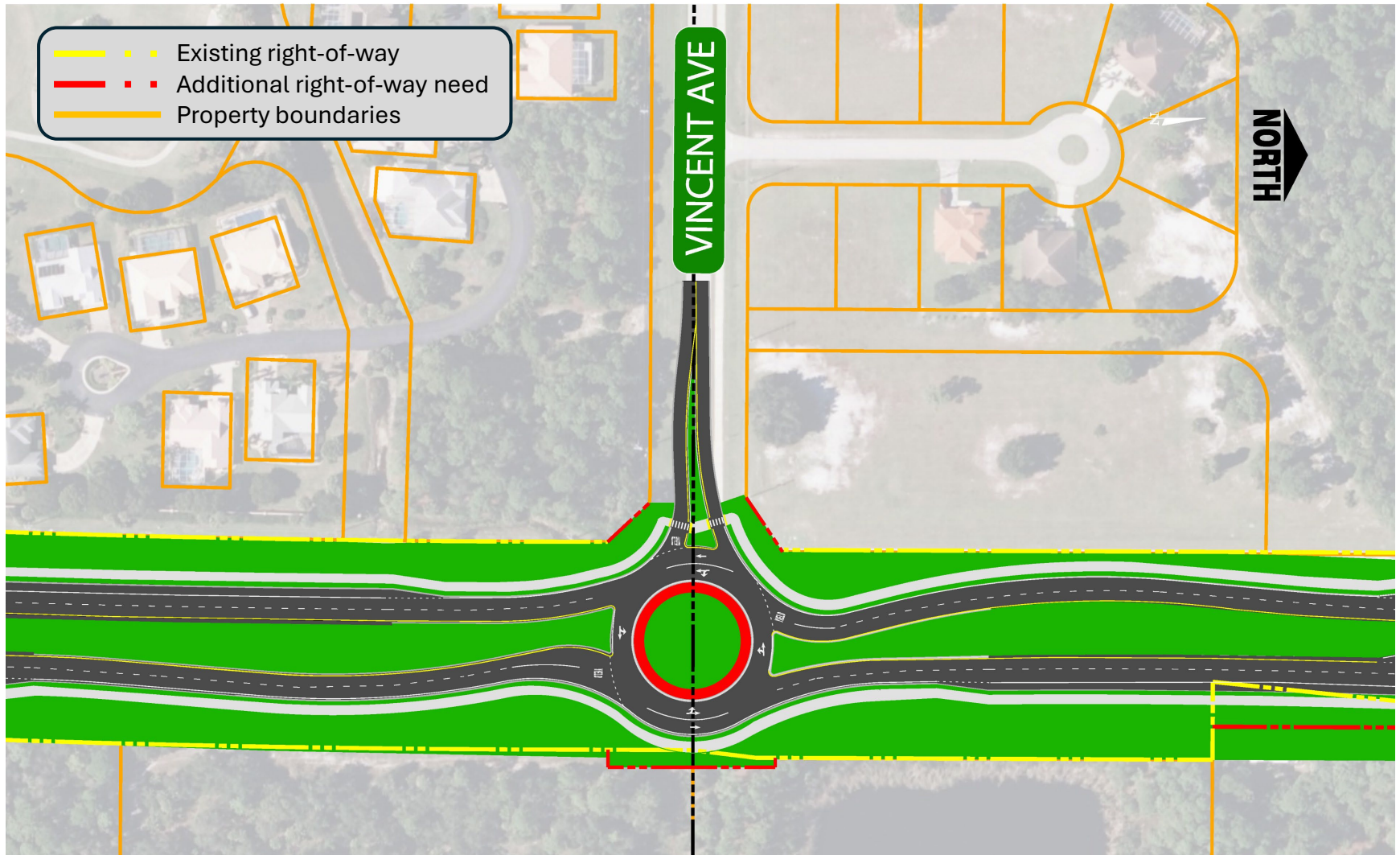

Note: Signalized pedestrian crossings will be evaluated during the design phase of the project.

# Signalized RCUT Concept

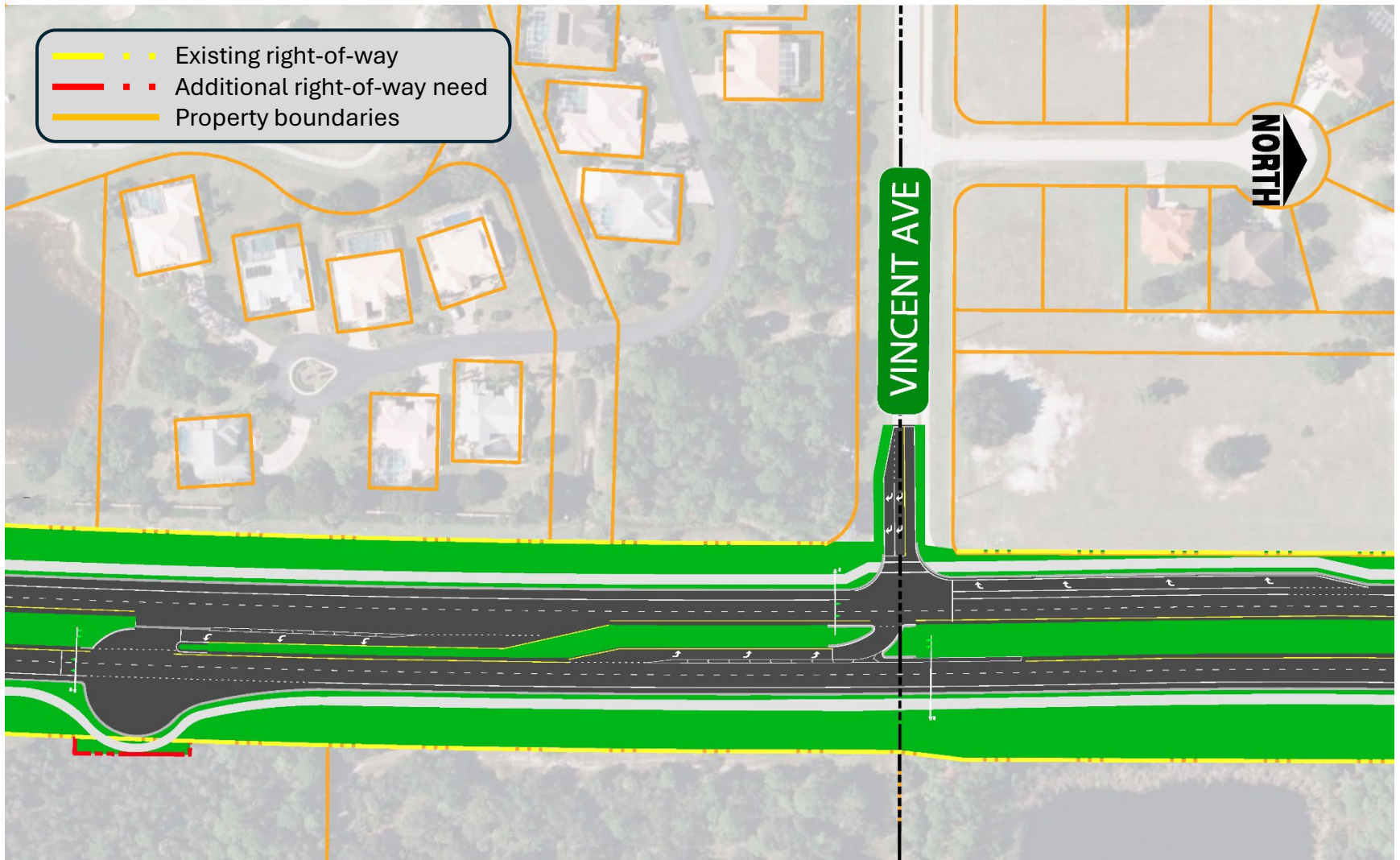

Note: Signalized pedestrian crossings will be evaluated during the design phase of the project.

# Traffic Signal (T-Intersection) Concept

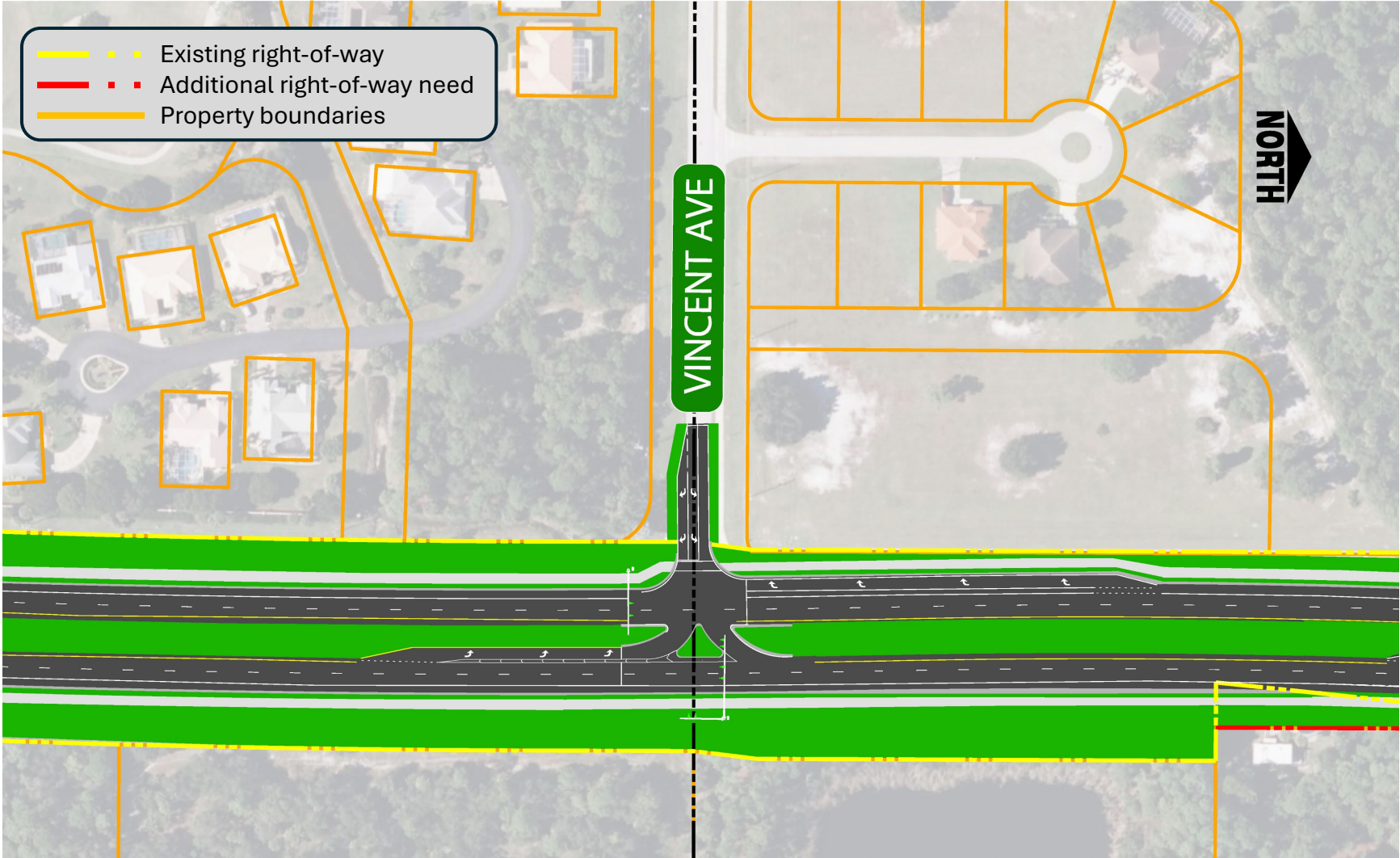

Note: Signalized pedestrian crossings will be evaluated during the design phase of the project.

# Continuous Green T (CGT) Intersection Concept

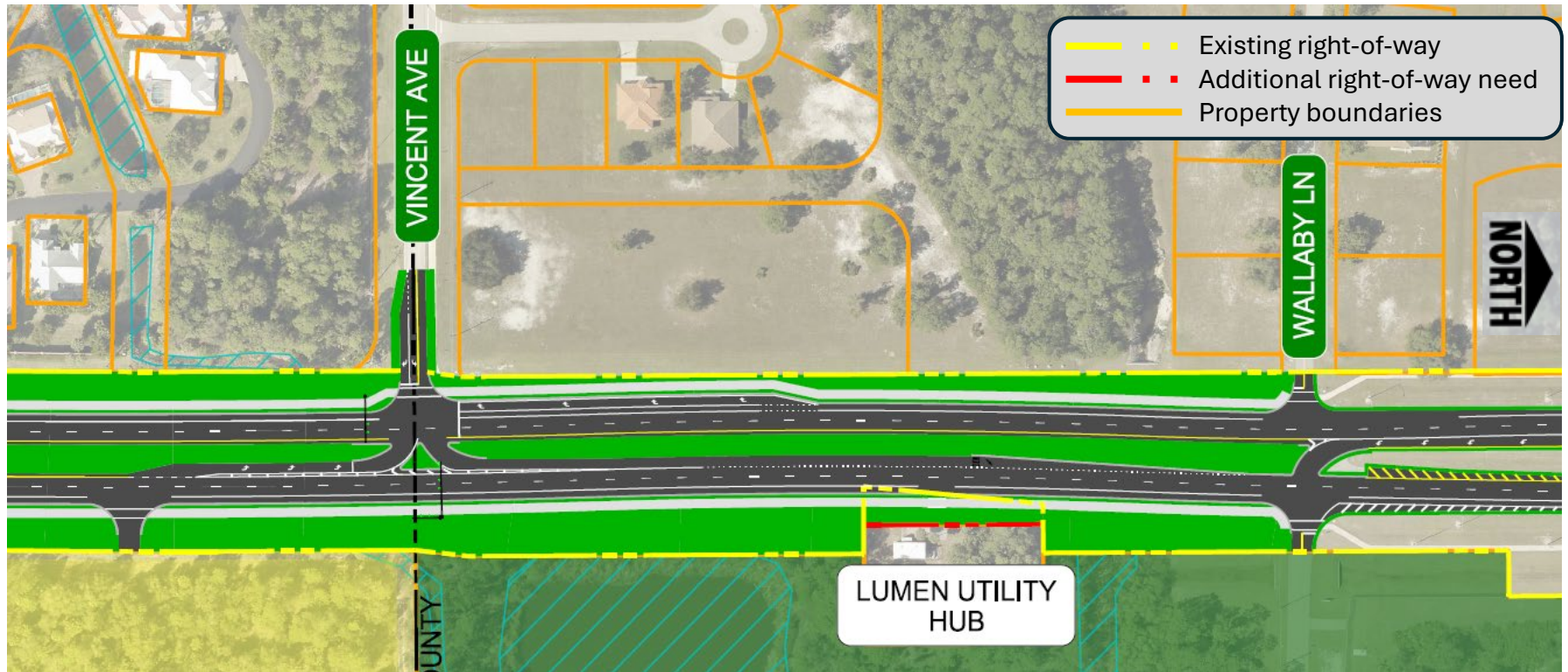

Note: Signalized pedestrian crossings will be evaluated during the design phase of the project.













## **Appendix F**

### **Operational Analysis**















### HCM Signalized Intersection Capacity Analysis 3: Burnt Store Rd & Vincent Ave

2045 Design Year PM Peak

						
Movement	EBL	EBR	NBL	NBT	SBT	SBR
Lane Configurations						
Traffic Volume (vph)	76	39	54	1244	2213	283
Future Volume (vph)	76	39	54	1244	2213	283
Ideal Flow (vphpl)	1900	1900	1900	1900	1900	1900
Total Lost time (s)	6.0	6.0	6.0	6.0	6.0	6.0
Lane Util. Factor	1.00	1.00	1.00	0.95	0.95	1.00
Frt	1.00	0.85	1.00	1.00	1.00	0.85
Flt Protected	0.95	1.00	0.95	1.00	1.00	1.00
Satd. Flow (prot)	1770	1583	1770	3539	3539	1583
Flt Permitted	0.95	1.00	0.06	1.00	1.00	1.00
Satd. Flow (perm)	1770	1583	113	3539	3539	1583
Peak-hour factor, PHF	0.92	0.92	0.92	0.92	0.92	0.92
Adj. Flow (vph)	83	42	59	1352	2405	308
RTOR Reduction (vph)	0	6	0	0	0	88
Lane Group Flow (vph)	83	36	59	1352	2405	220
Turn Type	Prot	pm+ov	pm+pt	NA	NA	Perm
Protected Phases	3	5	5	2	6	
Permitted Phases		3	2			6
Actuated Green, G (s)	6.0	12.0	72.0	72.0	60.0	60.0
Effective Green, g (s)	6.0	12.0	72.0	72.0	60.0	60.0
Actuated g/C Ratio	0.07	0.13	0.80	0.80	0.67	0.67
Clearance Time (s)	6.0	6.0	6.0	6.0	6.0	6.0
Lane Grp Cap (vph)	118	316	200	2831	2359	1055
v/s Ratio Prot	c0.05	0.01	0.02	c0.38	c0.68	
v/s Ratio Perm		0.02	0.22			0.14
v/c Ratio	0.70	0.11	0.29	0.48	1.02	0.21
Uniform Delay, d1	41.1	34.3	23.9	2.9	15.0	5.8
Progression Factor	1.00	1.00	1.00	1.00	1.00	1.00
Incremental Delay, d2	29.6	0.7	3.7	0.6	23.6	0.4
Delay (s)	70.7	35.0	27.6	3.5	38.6	6.3
Level of Service	E	D	C	A	D	A
Approach Delay (s)	58.7			4.5	34.9	
Approach LOS	E			A	C	
<b>Intersection Summary</b>						
HCM 2000 Control Delay			25.5		HCM 2000 Level of Service	C
HCM 2000 Volume to Capacity ratio			0.97			
Actuated Cycle Length (s)			90.0		Sum of lost time (s)	18.0
Intersection Capacity Utilization			76.2%		ICU Level of Service	D
Analysis Period (min)			15			
c Critical Lane Group						

3:

						
	NBL	NBT	SBT	SBR	EBL	EBR
Movement	EBL	EBT	WBT	WBR	SBL	SBR
Lane Configurations						
Traffic Volume (vph)	54	1244	2213	283	76	39
Future Volume (vph)	54	1244	2213	283	76	39
Ideal Flow (vphpl)	1900	1900	1900	1900	1900	1900
Total Lost time (s)	5.0	3.0	5.0	5.0	5.0	5.0
Lane Util. Factor	1.00	0.95	0.95	1.00	1.00	1.00
Fr <sub>t</sub>	1.00	1.00	1.00	0.85	1.00	0.85
Fl <sub>t</sub> Protected	0.95	1.00	1.00	1.00	0.95	1.00
Satd. Flow (prot)	1770	3539	3539	1583	1770	1583
Fl <sub>t</sub> Permitted	0.95	1.00	1.00	1.00	0.95	1.00
Satd. Flow (perm)	1770	3539	3539	1583	1770	1583
Peak-hour factor, PHF	0.92	0.92	0.92	0.92	0.92	0.92
Adj. Flow (vph)	59	1352	2405	308	83	42
RTOR Reduction (vph)	0	0	0	69	0	7
Lane Group Flow (vph)	59	1352	2405	239	83	35
Turn Type	Prot	NA	NA	pm+ov	Prot	pt+ov
Protected Phases	5	Free!	6	4	4!	4 5
Permitted Phases				6		
Actuated Green, G (s)	3.9	88.9	61.0	67.0	6.0	15.9
Effective Green, g (s)	4.9	88.9	62.0	69.0	7.0	16.9
Actuated g/C Ratio	0.06	1.00	0.70	0.78	0.08	0.19
Clearance Time (s)	6.0		6.0	6.0	6.0	
Vehicle Extension (s)	3.0		3.0	3.0	3.0	
Lane Grp Cap (vph)	97	3539	2468	1317	139	300
v/s Ratio Prot	0.03	0.38	c0.68	0.01	0.05	0.02
v/s Ratio Perm				0.14		
v/c Ratio	0.61	0.38	0.97	0.18	0.60	0.12
Uniform Delay, d <sub>1</sub>	41.1	0.0	12.7	2.6	39.6	29.8
Progression Factor	1.00	1.00	1.00	1.00	1.00	1.00
Incremental Delay, d <sub>2</sub>	10.3	0.3	12.6	0.1	6.7	0.2
Delay (s)	51.4	0.3	25.3	2.7	46.3	30.0
Level of Service	D	A	C	A	D	C
Approach Delay (s)		2.5	22.8		40.8	
Approach LOS		A	C		D	

Intersection Summary

HCM 2000 Control Delay	16.5	HCM 2000 Level of Service	B
HCM 2000 Volume to Capacity ratio	0.93		
Actuated Cycle Length (s)	88.9	Sum of lost time (s)	15.0
Intersection Capacity Utilization	74.5%	ICU Level of Service	D
Analysis Period (min)	15		

! Phase conflict between lane groups.

c Critical Lane Group

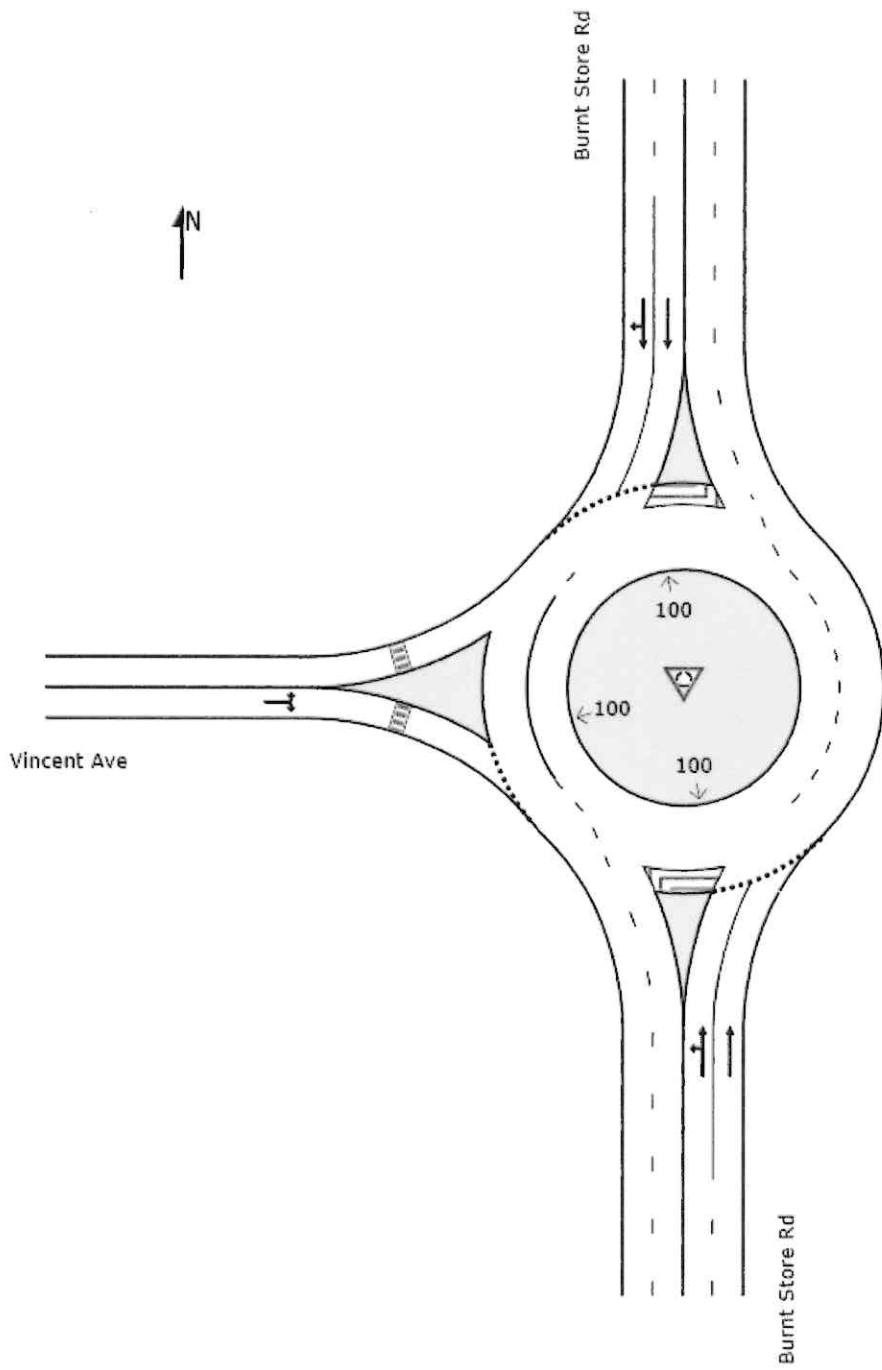

2x1 Roundabout Layout

## MOVEMENT SUMMARY

Site: 101 [BSR @ Vincent Ave (Site Folder: General)]

Output produced by SIDRA INTERSECTION Version: 9.1.6.228

2045 Design Year - PM Peak

Site Category: (None)

Roundabout

### Vehicle Movement Performance

Mov ID	Turn	Mov Class	Demand Flows [Total HV]	Arrival Flows [Total HV]	Deg. Satn	v/c	Aver Delay sec	Level of Service	95% Back Of Queue [Veh. Dst]	Prog. Que	Stop Rate	Aver. No. of Cycles	Aver. Speed mph
			veh/h	%					ft				
South: Burnt Store Rd													
3	L2	All MCs	59	7.8	59	7.8	0.579	LOS A	117.2	0.39	0.16	0.39	26.9
8	T1	All MCs	1352	7.8	1352	7.8	0.579	LOS A	117.2	0.39	0.16	0.39	27.2
Approach													
			1411	7.8	1411	7.8	0.579	LOS A	117.2	0.39	0.16	0.39	27.1
North: Burnt Store Rd													
4	T1	All MCs	2405	7.5	2405	7.5	1.092	LOS F	2928.1	1.00	1.63	1.76	20.0
14	R2	All MCs	308	7.5	308	7.5	1.092	LOS F	2928.1	1.00	1.62	1.76	17.5
Approach													
			2713	7.5	2713	7.5	1.092	LOS F	2928.1	1.00	1.63	1.76	19.8
West: Vincent Ave													
5	L2	All MCs	83	4.8	83	4.8	0.817	LOS F	68.4	0.97	1.20	1.65	11.9
12	R2	All MCs	42	4.8	42	4.8	0.817	LOS F	68.4	0.97	1.20	1.65	13.5
Approach													
			125	4.8	125	4.8	0.817	LOS F	68.4	0.97	1.20	1.65	12.6
All Vehicles													
			4249	7.5	4249	7.5	1.092	LOSE	2928.1	0.80	1.13	1.30	21.5

Site Level of Service (LOS) Method: Delay & v/c (HCM 6). Site LOS Method is specified in the Parameter Settings dialog (Options tab).

Roundabout LOS Method: Same as Sign Control.

Vehicle movement LOS values are based on average delay and v/c ratio (degree of saturation) per movement.

LOS F will result if v/c > 1 irrespective of movement delay value (does not apply for approaches and intersection).

Intersection and Approach LOS values are based on average delay for all movements (v/c not used as specified in HCM 6).

Roundabout Capacity Model: US HCM 6.

Delay Model: HCM Delay Formula (Stopping Delay: Geometric Delay is not included).

Queue Model: SIDRA queue estimation methods are used for Back of Queue and Queue at Start of Gap.

Gap-Acceptance Capacity Formula: Sigloch M1 implied by US HCM 6 Roundabout Capacity Model.

HV (%) values are calculated for All Movement Classes of All Heavy Vehicle Model Designation.

Annual Flows used in performance calculations are adjusted to include annual Initial On-Street Demand and Intersection Capacity Constraint effects.